

Windows taskbar: (8,369 unread) - amanspangabe..., Panggabean, Gas-Liquid Separator, WhatsApp, Download file | iLovePDF

Browser address bar: jos.unsoed.ac.id/index.php/jm/authorDashboard/submission/5039

MOLEKUL Submission Library View Metadata

Gas-Liquid Separator Modified on CV-AAS System for Determination of Total Hg in the Industrial Wastewater Samples

Sujito Sujito, Subur P Pasaribu, Teguh Wirawan, Aman Sentosa Panggabean

Submission **Review** Copyediting Production

Submission Files

18171-1 gabe_2021, Author, Manuscript_AmanSP et al_Molekul_2021.docx Article Text

[Download All Files](#)

Pre-Review Discussions

[Add discussion](#)

Name	From	Last Reply	Replies	Closed
Comments for the Editor	gabe_2021 Nov/18	-	0	<input type="checkbox"/>

Windows taskbar: Start, 19:55 26/06/2023

Revision requested

[Close Panel](#)

Participants

- Aman Sentosa Panggabean (gabe_2021)
- mardiyah kurniasih (mardiyah_kurniasih)

Messages

Note

From

Reviewer has now commented on your paper below this email and the attached file. You will see that the Reviewer is advising that you must revise your manuscript. If you are prepared to undertake the work required, I would be pleased to reconsider my decision.

If you decide to revise the work, please submit a list of changes or a rebuttal against each point which is being raised when you submit the revised manuscript. Please write difference color of the manuscript changes.

Please be noted that you have up to 1 (one) week from now to revise your manuscript.

If you need additional time to complete your revision, please let us know by replying to this email and informing us of the date you expect to submit it.

Reviewer Comments:

- This article describes the performance of CV-AAS in determining total mercury using a modified air separator but does not explain what modifications have been made anymore. Please explain what modifications were made so that the article's contents match the title of the article.
- Please, add where the industrial wastewater samples were obtained from and how the sampling process was carried out.
- Please, write the formula in Fig 2 correctly (use subscript for the coefficient) & also specified the concentration of the acids.
- The way the authors determine the LoD & LoQ in the discussion (Table 2) seems different from what they explain in the method section. Please describe the method clearly.
- Give main reaction on text.
- The English need to be improved.

[Author, Manuscript AmanSP et al Molekul 2021.docx](#)

Revision of Manuscript

[Close Panel](#)

Participants [Edit](#)

- Aman Sentosa Panggabean (gabe_2021)

Messages

Note

From

Title of Manuscript : **GAS-LIQUID SEPARATOR MODIFIED ON CV-AAS SYSTEM FOR DETERMINATION OF TOTAL Hg IN THE INDUSTRIAL WASTEWATER SAMPLES**

We have corrected several things that have been requested by reviewers to be improved in our manuscript :

1. Reviewer : This article describes the performance of CV-AAS in determining total mercury using a modified air separator but does not explain what modifications have been made anymore. Please explain what modifications were made so that the article's contents match the title of the article.

Response Author : In this article, the gas-liquid separator used modified by changing the geometry of separator and mixing techniques of the reactant (acid, sample and reductant) occur takes place the gas-liquid separators. The treatment corrects the weakness of commercial separators, as described in the article (section of Methods and Results and Discussion).

2. Reviewer : Please, add where the industrial wastewater samples were obtained from and how the sampling process was carried out.

gabe_2021
Jun 03

Response Author : The samples wastewater taken from the Industrial Wastewater Treatment Plant owned PT. Badak NGL, and the sampling process has been explain in the article secton Methods (sample preparation).

3. Reviewer : Please, write the formula in Fig 2 correctly (use subscript for the coefficient) & also specified the concentration of the acids.

Response Author : The formula in Fig. 2 and specified the concentration of the acids has been corrected in the article.

4. Reviewer : The way the authors determine the LoD & LoQ in the discussion (Table 2) seems different from what they explain in the method section. Please describe the method clearly.

Response Author : Determination of the LoD and LoQ has been fixed and adjusted as in the method, results and discussion section (Table 2).

Note

From

5. Reviewer :Give main reaction on text.

Response Author : The reaction of hydride forming has been added in the results and discussion section.

6. Reviewer :The English need to be improved.

Response Author : The English in the text of the article has been repair and improved.

Best regards,

Aman Sentosa Panggabean

[gabe_2021, Author, Manuscript Aman SP et al., 2022_rev.docx](#) [gabe_2021, Author, Manuscript Aman SP et al., 2022_rev.docx](#)

Revision of manuscript before layout

[Close Panel](#)

Participants [Edit](#)

- Aman Sentosa Panggabean (gabe_2021)

Messages

Note

We have corrected several things that have been requested by editors to be improved in our manuscript before layout.

Best regards

Aman Sentosa Panggabean

[gabe_2021, Author, Manuscript 5039_Rev2.docx](#)

From

gabe_2021
Aug 30

Revision of manuscript before layout

Participants [Edit](#)

Aman Sentosa Panggabean (gabe_2021)

Messages

Note	From
We have corrected several things that have been requested by editors to be improved in our manuscript before layout.	gabe_2021 Aug 30

Best regards

Aman Sentosa Panggabean

[gabe_2021, Author, Manuscript 5039_Rev2.docx](#)

[Add Message](#)

Windows taskbar: 19:58 26/06/2023

Notifications

[jm] Editor Decision

2022-09-01 12:21 AM

Aman Sentosa Panggabean:

We have reached a decision regarding your submission to Molekul, " GAS-LIQUID SEPARATOR MODIFIED ON CV-AAS SYSTEM FOR DETERMINATION OF TOTAL Hg IN THE INDUSTRIAL WASTEWATER SAMPLES".

Our decision is to: Accept Submission

mardiyah kurniasih
Universitas jenderal Soedirman
m_kurniasih@yahoo.com

[Molekul](#)

Windows taskbar: 20:12 26/06/2023

GAS-LIQUID SEPARATOR MODIFIED ON CV-AAS SYSTEM FOR DETERMINATION OF TOTAL Hg IN THE INDUSTRIAL WASTEWATER SAMPLES

Sujito^{1,2}, Subur P. Pasaribu², Teguh Wirawan², Aman Sentosa Panggabean^{*2}

¹Laboratory of Environment Control, P.T. Badak NGL-East Kalimantan, Bontang-Indonesia

²Department of Chemistry, Mulawarman University, Samarinda, 75119, Indonesia

*email: amanspanggabean@yahoo.com

ABSTRACT

The research about the utilization of modified gas-liquid separators in the determination of Hg ions by using the Cold Vapor Atomic Absorption Spectrophotometer (CV-AAS) method has been done. To optimize the measurement results, several parameters that affect the hydride generator have been studied. Some specified essential parameters are the type and concentration of acid, the level of SnCl₂ as a reducing agent, sample volume and the analytical performance such as linearity (r), detection limit (LOD) and quantitation limit (LOQ), repeatability (% RSD), and accuracy have been studied. The results of the research showed the gas-liquid separator modified can be used instead of commercial gas-liquid separators. It was showed by the repeatability value as % RSD < 2/3 CV Horwitz values, the LOD was 0.2530 µg/mL, and the LOQ was 0.8432 µg/mL. The accuracy of this method was good shown by a recovery percentage of 101.6%. Based on the result of this research, the modified of gas-liquid separator can be used for the determination of Hg ions by using the CV-AAS method with valid results.

Keywords: CV-AAS, Gas-liquid Separator, Hg, Wastewater.

INTRODUCTION

Hg is one of the most toxic elements among the studied heavy metals and exposure to high level of this element could permanently damage the brain, kidneys and developing foetus. It is prone to accumulation in biota and represents a serious problem when released to the environment, being recognized as a large scale global pollutant (Wilhelm, 2011). Hg can be found naturally in water, soil, sediment, plant, and air as a negative impact of a specific activity or use, e.g. mining, paint industry, pesticide use in agriculture, drugs, and other industrial waste (Veronesi et al., 2013). Hg is a global pollutant which requires a great attention due to its bioaccumulation properties and reactivity. It is highly toxic even in low concentrations, and its dispersion in the environment is due to natural emissions or anthropogenic activities. Thus, the need for the development and validation of analytical methodologies for the determination and control of this toxic metal in samples is evident (Panggabean et al., 2018; Oreste et al., 2013).

Several spectrometric techniques were already employed for total Hg determination in the samples. Cold vapor-atomic absorption spectrometry (CV-AAS) is the most widely used technique for the determination of mercury because of its high sensitivity, resistance to interferences and operational simplicity (Gorecki et al., 2018). The advantages of using the CV-AAS method are having a high level of sensitivity and accuracy, which can be applied to analyze in ultra micro level (ppt). Hydride generation (HG) is a very effective analytical technique developed to separate hydride forming metals, such as Hg, from a range of matrices and varying acid concentrations. Hg ion in the acidic atmosphere will be reduced by reaction with SnCl₂ or NaBH₄ solution in a vessel outside the AAS instrument (Martín-Yerga et al., 2013). This vessel is called a liquid-gas separator which is an essential part of the formation of metal hydrides (Panggabean et al., 2013). SnCl₂ is the active reducing agent that can convert mercury ions (Hg₂²⁺/Hg²⁺) in a sample to neutral Hg (Hg⁰). The Hg⁰ atom formed in the previous step will be carried by inert gas to the quartz tube cell installed in the AAS instrument (Gorecki et al., 2018).

Gas-liquid separator separator which are commonly used in HG techniques, are not optimal in separating the gas hydride metal formed with the liquid. The liquid sometimes enters to the quartz tube cell and causes crust, which greatly interferes with the measurement process. The cause of the onset of crust is thought to be excessive reductant concentration or high acid concentration, so the hydride formation reaction takes place too quickly. Hydride metal that are formed are not completely separate from the solution. The problems can be overcome by modifying the shape and size of the commercial gas liquid separator (Panggabean et al., 2013). Gas liquid Separator modified was expected to improve the performance of measurement results to the maximum

Several studies on determination of Hg in various samples using CV-AAS technique has been reported, such as: determination of Hg level in fish (Chen et al., 2013; Da Silva et al., 2019; Fashi et al., 2017; Zhu et al., 2017), groundwater and river using electrochemical CV-AAS technique (Karthika et al., 2019; Some et al., 2016), oil samples (Payehghadr et al., 2014; Veronesi et al., 2013; Vicentino et al., 2015), environmental samples (Gao et al., 2012; Le Roux et al., 2016; Oreste et al., 2013), hair (Domanico et al., 2017), determination of Hg level in honey, pollen, and greek bees (Maragou et al., 2016), and seafood using photochemical vapor generation capacitively coupled plasma microtorch optical emission spectrometry (Covaci et al., 2017), reported that the results obtained are valid and can be justified.

In this study, a liquid gas separator modified has been used for determination of Hg ions in wastewater samples. The liquid gas separator has previously been used to determine Cd (Ritschdorff et al., 2005) and Sn (Panggabean et al., 2013) ions, by the HG method. Some important parameters in the determination of Hg ions using CV-AAS technique, such as type and concentration of acid/reductant, and sample volume have been carried out. The optimum conditions obtained are used to determine the analytical performance of measurements and determination of Hg ions in the wastewater samples. The results of research obtained, will show whether the liquid-gas separator modified can be proposed as an alternative a replacement of commercial liquid-gas separator in the determination of Hg ions using CV-AAS technique.

EXPERIMENTAL SECTION

Materials: Material used in this research were solution of CRM Hg WatRTM Pollution Mercury with a concentration of $22.6 \mu\text{g/L} \pm 8.65\%$ and acceptance Limit $15.8 - 29.4 \mu\text{g/L}$, Hg stock solution 1000 mg/L , $\text{SnCl}_2 \cdot 2\text{H}_2\text{O}$, HCl, H_2SO_4 , HNO_3 , double-distilled water, argon gas; all reagents were of analytical reagent grade (E' Merck).

Instrumentation: The equipment used in this research were Atomic Absorption Spectrophotometer Agilent AA-240 FS and a set of construction hydride generator that equipped by a peristaltic pump and gas-liquid separator modified, record system and computer. Other equipment such as laboratory standard glassware, analytical balance, oven, and hot plate with stirrer was used for all measurement.

Methods

The Equipment of CV-AAS System With Gas-liquid Separator

The gas-liquid separator is host to the metal hydride formation process prior continuation to quartz cell tube placed above AAS furnace. The schematic of CV-AAS equipment, with gas-liquid separator can be seen in fig. 1.

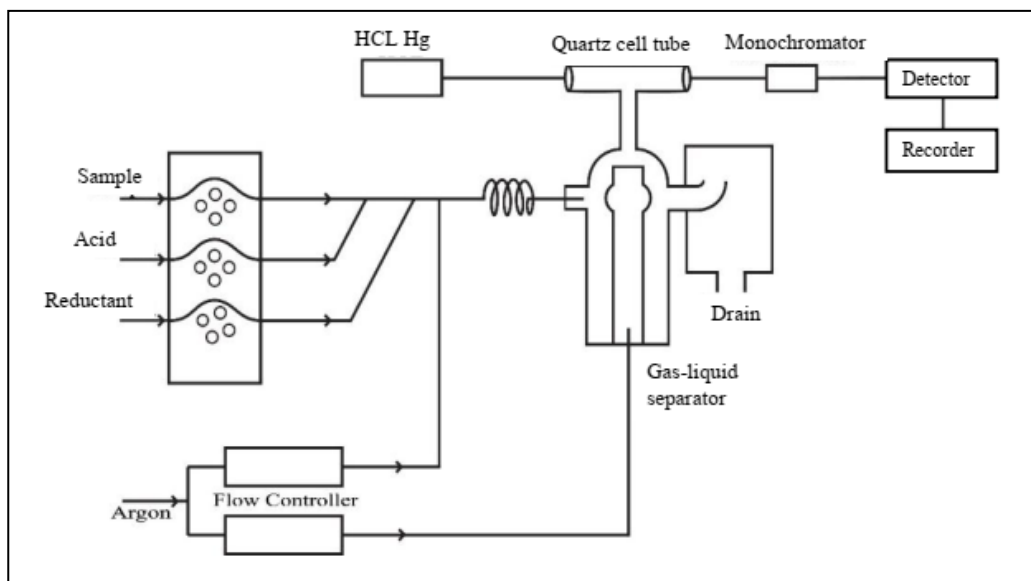

Fig. 1. CV-AAS equipment with gas-liquid separator

Analytical Conditions of AAS Parameters

The operating procedure is according to Agilent AA-240 FS manual book with analytical parameters, as in table 1.

Table 1. Analytical AAS Parameters

Parameter	Operating Conditions
Cathode Lamp	Hg
Wavelength	253.7 nm
Slit	0.5 nm
Lights Intensity	100.01
Lights Current	8.0 mA
Sensitivity Check	Conc. 11.5 µg/L for 0.2 Abs

Determination of Optimum Conditions for Hg Ion Measurement with CV-AAS Technique

To obtain the optimum measurement conditions for measuring Hg ions, an optimization condition is performed by varying various parameters that affect the measurement results such as; acid type and concentration (HCl, H₂SO₄, and HNO₃), SnCl₂ concentration, and sample volume.

Effect of Acid Type and Concentration. Optimization of acid types is done by varying the types of acids, while the volume of the sample, and the concentration of SnCl₂ is made

constant. From the experiments will be obtained the type of acid that provides an optimal response. The optimal of the acid type, will be used for the next stage of research by varying the concentration of the acid. The optimal acid concentration was varied in acid concentration 0.25 – 1.50 % v/v.

Effect of SnCl₂ Concentration. After knowing the optimal type and concentration of acid, SnCl₂ concentration is varied with other parameters (sample volume, type and concentration of acid) made constant. The variation of SnCl₂ concentration are 0.10 - 1.50% w/v.

Optimization of Sample Volume. The optimum sample volume should be determined to get minimum volume of sample required that give maximum absorbance.

Analytical Performance of Hg Ion Measurement with CV-AAS Technique

Calibration Curves and Determination of Regression Line Equations. At this stage, measurements were made to find the linear range of measurements by varying the concentration of the standard Hg series solution, with parameters of sample volume, concentration, and type of acid, concentration of SnCl₂, and acid flow rate and SnCl₂ being made constant. Variations in the standard Hg series are 1, 3, 5 and 7 µg/L. From this experiment, a regression line equation will be obtained which will be used to calculate the Hg concentration by plotting the absorbance measured with the concentration of a standard series solution.

Determination of Detection Limits. Detection limits was determined by measuring the absorbance of the blank solution several times (n=10). The blank solution used was aquibdest plus 5% HNO₃ (v/v) and 5% HCl (v/v). Based of the absorbance value of the blank measurement, it can be determined the value of standard deviation (SB), LOD ($\bar{X} + 3 \times SB$) dan LOQ ($\bar{X} + 10 \times SB$).

Determination of Repeatability. Repeatability was determined by measuring the absorbance of standard solutions of Hg²⁺ 3.0 and 5.0 µg/L by 10 times each (n=10). Repeatability was indicated by the percentage coefficient of variance (% CV). A repeatability value is accepted if % CV is less than % CV Horwitz.

Determination of Accuracy. The accuracy parameter was performed with the spike method and the reference method. This spike method is done by making a standard solution of Hg (100 µg/L) 2 mL into volumetric flask 100 mL, and diluted with a sample

solution. From the results of standard spike measurements, the percentage of recovery was calculated as:

$$\% \text{ Recovery} = \left(\frac{C_{\text{spike}} - C_{\text{sample}}}{C_{\text{standard}}} \right) \times 100\% \quad 1)$$

The reference method is carried out by measuring CRM, where the measurement results are compared with the values stated in the CRM certificate.

Sample Preparation

The Sample used in this research is wastewater from the Industrial Wastewater Treatment Plant owned PT. Badak NGL. A totla of 100 mL of wastewater sample was put in a volumetric flask, containing no more than 5.0 µg/L Hg. Into the volumetric flask added 25 mL of KMnO₄ and 8 mL of K₂S₂O₈, heated in a water bath at 95 °C for 2 hours. After being cooled, added 6 ml of sodium chloride-hydroxylamine HCl into the flask to remove the free chlorine formed.

RESULTS AND DISCUSSION

Gas-Liquid Separator Modified Integrated to Hydride Generation Systems

In the determination of Hg ions using the CV-AAS technique, Hg(II) ions are first derivatized into the hydride form, then atomized in AAS quartz cell tube placed above the AAS furnace. The hydride formation process takes place in a gas-liquid separator, according to reactions below;

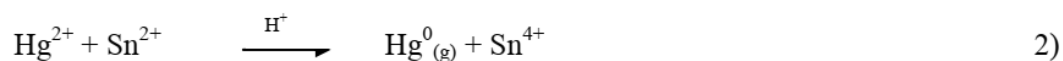

The Commercial of gas liquid separator, commonly used in this analytical technique are often not optimal in separating the hydride vapor from the liquid, because the reaction process takes place inside the coil reaction before going to the gas-liquid separator the liquid is carried into the quartz cell tube (as can be seen in the fig 2.a.) and causes interference with the measurement. The problem can be solved by modifying the gas liquid separator. The shape and size of the gas-liquid separator will have a significant influence on the metal-hydride vapor generation process. The gas liquid separator

modified (fig 2.b.), provides a better performance of separating gas hydride from the liquid, because the reaction process direct mixing taking place in the separator (Panggabean et al., 2013), and the possibility of carry over is smaller.

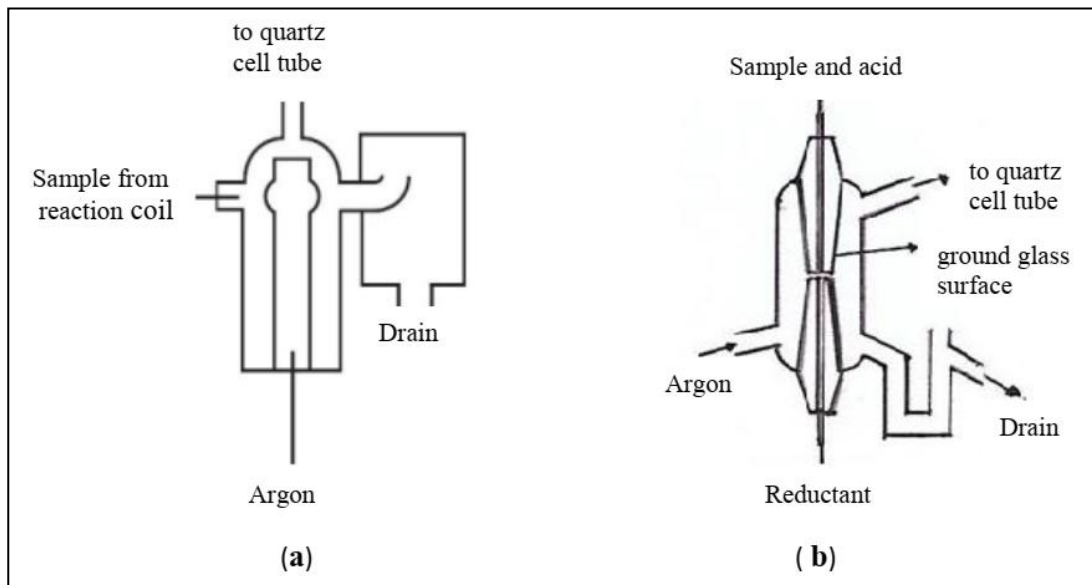

Fig. 2. Gas-liquid separator; (a) Commercial; (b) Modified

Optimization of Acid Type Used

The acid solution in the hydride process in the Hg analysis serves to provide an acidic atmosphere so that the reduction reaction can take place (Gorecki et al., 2018). In this research, variations of acid types (HCl, H₂SO₄, and HNO₃) with the same concentration 1 %, to measure the standard Hg 1.0; 3.0 and 5.0 µg/L. The measurement results can be seen in Fig. 3.

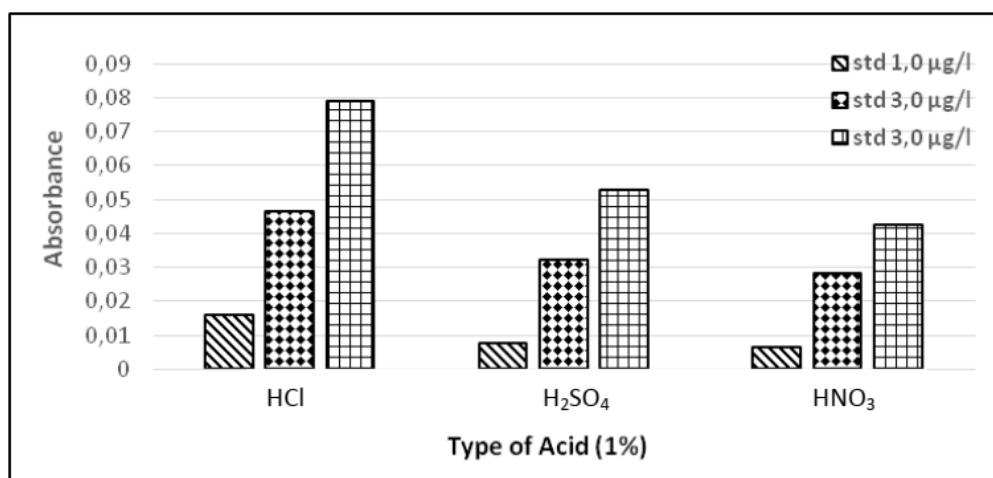

Fig. 3. The influence of acid type in the determination of Hg using CV-AAS

In this research, HCl provides maximum absorbance. The utilization of H₂SO₄ and HNO₃ as a giver of acidic does not provide maximum results. This because both acids are oxidizing agents so that the oxidation-reduction reaction process in the formation of a metal hydride in the gas-liquid separator disturbed (Panggabean et al., 2018). For further work, this acid is used in the hydride formation process.

Optimization of HCl Concentrations

Acid was one of the important parameters affected at the time process of hydride formation. The influence of HCl concentration on the hydride formation process, in the determination of Hg using CV-HG-AAS method was presented in Fig. 4.

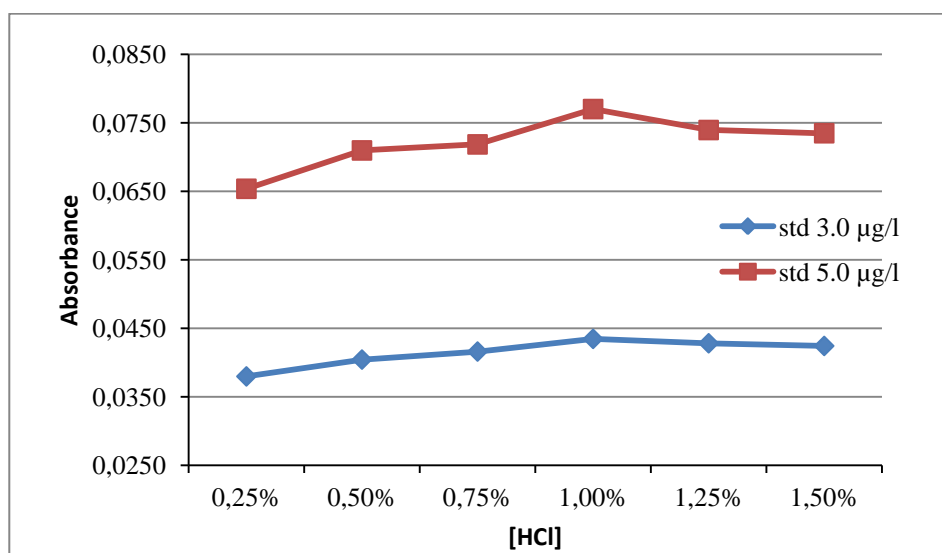

Fig. 4. Effect of HCl concentration in determination of Hg using CV-AAS

The results obtained in this experiment (Fig. 3) showed, determination of absorbance of Hg 3.0 and 5.0 µg/L standard increases for each concentration variations HCl of 0.25 - 1% v/v, and at concentrations HCl in above 1% v/v, absorbance is relatively not significantly different or even slightly decreased. It can be concluded that the optimum of HCl concentration was 1% v/v. The higher HCl concentrations will cause the ratio of the amount of H₂ gas produced by the hydride reaction to be higher too, and this makes the Hg hydride diluted and make the Hg reading results become smaller (Domanico et al., 2017).

Optimization of SnCl₂ concentration as a reductant

To determine of the influence of the SnCl₂ concentration in reducing Hg²⁺ ion into Hg⁰ in the hydride formation process, performed with varying the concentration of SnCl₂ at a constant acid concentration (1% HCl) and Hg standard 3.0 and 5.0 µg/L. The results of this experiment can be seen in Fig. 5.

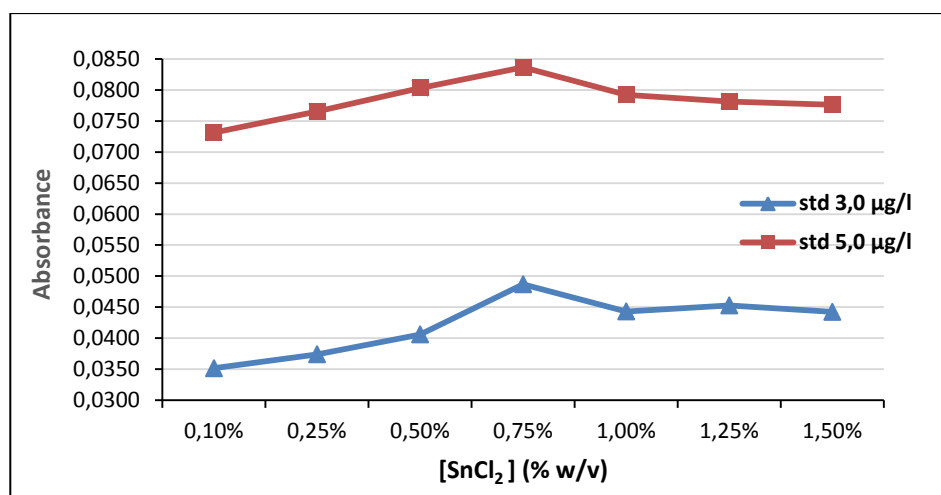

Fig. 5. Effect of SnCl₂ concentration in determination of Hg using CV-AAS

The result of research shown the optimum SnCl₂ concentration was 0.75 % w/v (Fig. 5.). While the SnCl₂ concentration lower than 0.75% w/v the absorbance results are also lower, at SnCl₂ concentrations above 0.75% w/v absorbance are relatively the same or even slightly decreased. At the high concentrations of SnCl₂, the reaction will be faster and produce a large amount of H₂ gas formed, and can be reducing the metal-hydride population formed. In this condition, the reaction will go too fast, so that several liquids come out of the separator (carry over) (Maragou et al., 2016; Panggabean et al., 2013). Carry over can disturb of the absorbance reading process and cause glassware (separator and T Tube cell) to crust.

Optimization of Sample Volume

Sample volume is very important to determine, to obtain the minimum sample volume needed for measurement in formation of hydride processes, so that the result will be valid. The optimization of sample volume can be see in Fig. 6.

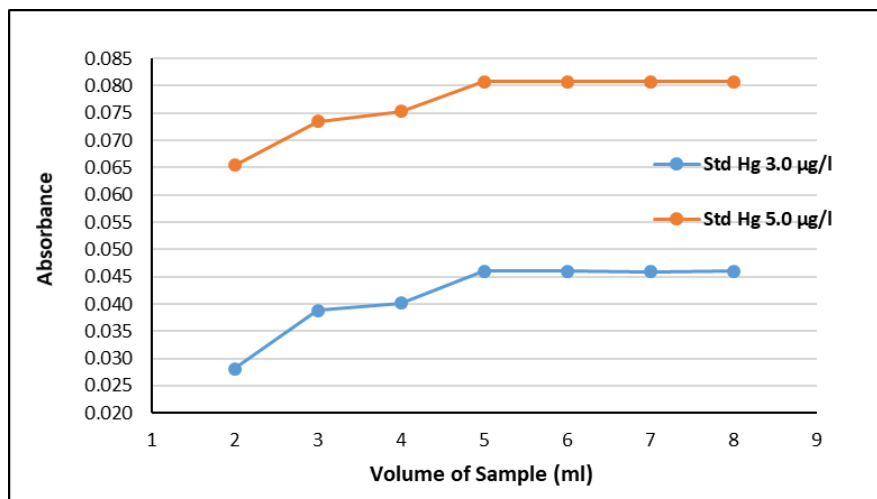

Fig. 6. Optimization of Sample Volume

Based on the measurement results (Fig. 6), the optimal sample volume is 5 mL. Under these conditions, the total population of Hg^{2+} ions to be made in the form of hydrides is maximal, at the optimum conditions of HCl and SnCl_2 as reductants used. If the sample volume is more than 5 mL, the measurement of sample absorbance is not significantly different.

Analytical Performance for Determination of Hg using CV-AAS

Determination of Linearity

Linearity is the ability of the analytical method to provide a proportional response to the concentration of the analyte in the samples. Linearity is usually expressed in terms of variance around the direction of the regression line which is calculated based on mathematical equations (Vicentino et al., 2015). Measurement results are shown in Fig. 7.

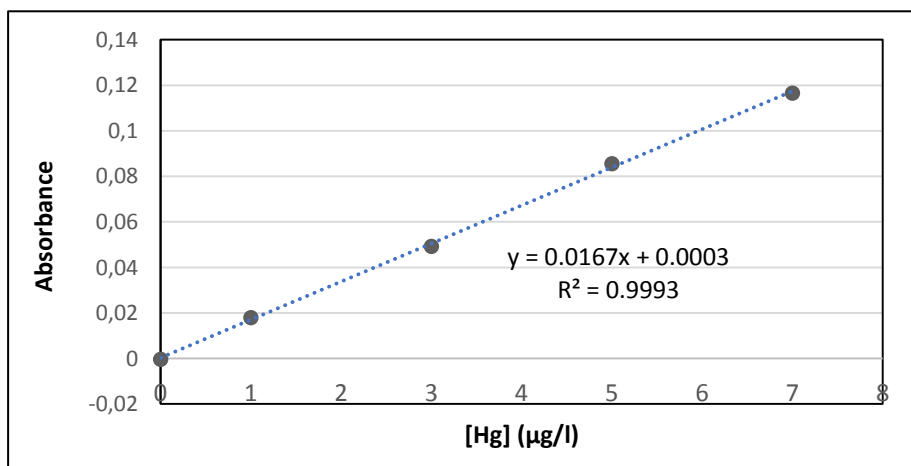

Fig. 7. Calibration Curve Hg using CV-AAS

The concentration of Hg standards are in the range 1.0-7.0 µg/L. The linear regression equation are $y = 0.0167x + 0.0003$ with coefficient of correlation (R^2) = 0.9993. The measurement results of Hg standard very good for Hg analysis, shown by the coefficient of correlation (R^2) are > 0.995 (Panggabean et al., 2018). These results indicate an excellent measurement for the analysis of Hg ions by the CV-AAS method.

Repeatability Measurement

Repeatability is a measure that shows the degree of agreement between individual test results from the average if the procedure is applied repeatedly to samples taken from a homogeneous mixture. Precision is measured as a relative standard deviation (% RSD). The precision results are stated well if the % KV value $\leq 2/3$ KV Horwitz (Panggabean et al., 2018). In this study, repeatability is determined by measuring the concentration of Hg standard solution 3.0 and 6.0 µg/L and Hg CRM solution 17.9 – 27.3 µg/L repeatedly with optimum conditions.

The result of the research showed, % RSD of Hg standard solution 3.0 µg/L was $0.857\% < 25.739$, % RSD of Hg standard 6.0 µg/L was $0.483\% < 23.702$ and % RSD of Hg CRM solution 17.9–27.3 µg/L was $0.751\% < 18.683$. All of % RSD of each Hg standard $< 2/3$ of CV Horwitz. This result indicated the good repeatability and acceptable measurement.

Determination of Accuracy

Accuracy states the degree of closeness of the analysis results with the actual level of the analyte. Accuracy is stated as a percentage of recovery of analytes added (Simanjuntak et al., 2020). In this study, the accuracy value is determined in two ways: the first way is to measure the concentration of Hg standard solution 1.0 µg/L (spike sample), and measurements of samples without the addition of the Hg standard, then % recovery value was calculated. The result of the research showed % recovery measurement of Hg standard 1.0 µg/L was 103.01 ± 3.25 . Each Hg standard result was in the range of required recommendation % recovery is 95–105% (Panggabean et al., 2018), and the accuracy was accepted.

The second way is to measure standard of Hg CRM $22.6 \mu\text{g/L} \pm 8.65\%$ repeatedly, then by comparing the mean of measurements with CRM values and acceptance limits stated in the certificate of CRM, which was shown in Table 2. The Mean Value of CRM

was $24.138 \pm 0.181 \mu\text{g/L}$ and accordance within the concentrations range CRM Hg $22.6 \mu\text{g/L} \pm 8.65\%$, acceptance limit was $15.8 - 29.4 \mu\text{g/L}$, and the accuracy was accepted.

Limit Detection and Limit Quantity Test (LOD and LOQ)

The detection limit expressed as the smallest minimum concentration or mass that can still be detected by an analysis method with a high level of confidence. The detection limit is determined by measuring the smallest absorbance price that can still be distinguished from the signal given of the blank, make repeated measurements on the same condition (Ritschdorff et al., 2005).

Table 2. Detection and Quantitation Limit Test

Measurement [Hg] (0.10 $\mu\text{g/L}$)	Absorbance	Hg Concentration ($\mu\text{g/L}$)
1	0.0005	0.0120
2	0.0003	0.0810
3	-0.0001	0.0680
4	-0.0002	0.0560
5	0.0001	0.0500
6	0.0004	0.0680
7	0.0003	0.0560
8	0.0002	0.0560
9	0.0004	0.0500
10	0.0003	0.0620
Average (X)		0.0559
Standard Deviation (SD)		0.0181
LoD = X + (3xSD)		0.0540
LoQ = X + (10xSD)		0.2370

Table 2. showed that the LOD value was $0.054 \mu\text{g/L}$, and LOQ was $0.237 \mu\text{g/L}$. These results indicate the lowest analytes concentration and the smallest quantity that can be determined by a method with complete application to the technique used with the conditions agreed in the test laboratory.

CONCLUSION

The results of the research showed that the modified liquid-gas separator can be use for the determination of Hg ions, with The optimum condition for measuring Hg in industrial wastewater by the CV-AAS method is as follows: the type of acid used is an HCl with 1% v/v concentration, a SnCl_2 : 0.75% w/v, and sample volume 6 mL. The analytical performance modified liquid gas separator in CV-AAS system very good, which are shown the repeatability values as $\% \text{RSD} < 2/3 \text{ CV Horwitz}$ values, the LOD was

0.054 µg/L and the LOQ was 0.237 µg/L. The accuracy of this method is good shown by a recovery percentage was $103.01 \pm 3.25\%$, the CRM readings are 24.138 ± 0.181 µg/L and accordance within the CRM certificate of the range Acceptance Limit 15.8 – 29.4 µg/L. Based on this research, the modified liquid-gas separator can be a substitute for commercial liquid-gas separator for the determination of Hg ions in the samples by using CV-AAS with valid results.

ACKNOWLEDGEMENT

The authors would like to thank the Chairman and staff of P.T. Badak NGL Bontang, East Kalimantan for the laboratory facilities and the samples provided in the implementation of this research.

REFERENCES

- Chen, X.P., Han, C., Cheng, H.Y., Liu, J.H., Xu, Z.G., & Yin, X.F., (2013), Determination of Mercurial Species in Fish by Inductively Coupled Plasma Mass Spectrometry with Anion Exchange Chromatographic Separation. *Analytica Chimica Acta*, 796, 7-13.
- Covaci, E., Senila, M., Ponta, M., Darvasi, E., Petreus, D., Frentiu, M., & Frentiu, T., (2017), Methylmercury Determination in Seafood by Photochemical Vapor Generation Capacitively Coupled Plasma Microtorch Optical Emission Spectrometry, *Talanta*, 170, 464-472.
- Da Silva, D.L.F., da Costa, M.A.P., Silva, L.O.B. & dos Santos, W.N.L., (2019), Simultaneous determination of mercury and selenium in fish by CV-HG-AFS, *Food Chemistry*, 273, 24–30.
- Domanico, F., Forte, G., Majorani, C., Senofonte, O., Petrucci, F., Pezzi, V., & Alimonti, A., (2017), Determination of Mercury in Hair: Comparison Between Gold Amalgamation-Atomic Absorption Spectrometry and Mass Spectrometry, *Journal of Trace Elements in Medicine and Biology*, 43, 3-8.
- Fashi, A., Yaftian, M.R. & Zamani, A., (2017), Electromembrane extraction-preconcentration followed by microvolume UV-Vis spectrophotometric determination of mercury in water and fish samples, *Food Chemistry*, 221, 714–720.

- Gao, Y., Shi, Z., Long, Z., Wu, P., Zheng, C. & Hou, X., (2012), Determination and speciation of mercury in environmental and biological samples by analytical atomic spectrometry, *Microchemical Journal*, 103, 1–14.
- Gorecki, J., Burmistrz, P., Trzaskowska, M., Sołtys, B. & Golas, J., (2018), Method development and validation for total mercury determination in coke oven gas combining a trap sampling method with CV-AAS detection, *Talanta*, 188, 293–298.
- Karthika, A., Raja, V.R., Karuppasamy, P., Suganthi, A. & Rajarajan, M., (2019), Electrochemical behaviour and voltammetric determination of mercury (II) ion in cupric oxide/poly vinyl alcohol nanocomposite modified glassy carbon electrode, *Microchemical Journal*, 145, 737–744.
- Le Roux, S. Baker, P. & Crouch, A., (2016), Determination of mercury in selected polluted sediments using HPLC-ICP-MS in Westbank area, Western Cape, South Africa, *South African Journal of Chemistry*, 69, 124–131.
- Maragou, N.C., Pavlidis, G., Karasali, H., & Hatjina, F., (2016), Cold Vapor Atomic Absorption and Microwave Diegestion for The Determination of Mercury in Honey. Pollen. Propolis And Bees of Greek Origin, *Global Nest Journal*. 18(4), 690-696.
- Martín-Yerga, D. González-García, M.B. & Costa-García, A., (2013), Electrochemical determination of mercury: a review, *Talanta*, 116, 1091–1104.
- Oreste, E.Q. Jesus, A., de Oliveira, R.M., da Silva, M.M., Vieira, M.A., & Ribeiro, A.S., (2013), New design of cold finger for sample preparation in open system: Determination of Hg in biological samples by CV-AAS, *Microchemical Journal*. 109, 5–9.
- Panggabean, A.S., Pasaribu, S.P., Amran, M.B., & Buchari., (2013), Gas-liquid separator integrated to HG-QFAAS method for determination of tin at trace levels in the water samples, *Eurasian Journal of Analytical Chemistry*. **8(1)**. 17-27.
- Panggabean, A. S, Pasaribu, S. P., & Kristiana, F., (2018), The Utilization of Nitrogen Gas a Carrier Gas in Determination of Hg Ions Using Cold Vapor-Atomic Absorption Spectrophotometer (CV-AAS), *Indonesian Journal of Chemistry*, 18(2), 279-285.

- Payehghadr, M., Shafiekhani, H., Sabouri, A. R., Attaran, A. M & Rofouei, M. K., (2014), Cold Vapor Atomic Absorption Determination of Hg in Crude Oil and Gasoline Samples after Solid Phase Extraction Using Modified Disks, *Iran. J. Chem. Chem. Eng.* 33(2), 1-10.
- Ritschdorff, E.T., Fitzgerald, N., Mclaughlin, R.G.J., & Brindle, I.D., (2005), The use of a Modified Multimode Sample Introduction System for the Simple and Rapid Determination of Cadmium by Chemical Vapour Generation Atomic Absorption Spectrometry, *Spectrochimica Acta, Part B*, 60(1), 139–143.
- Simanjuntak, L.H., Erwin, & Panggabean, A.S., (2020), Prakonsentrasi Ion Cd(II) dalam Sampel Pupuk Nitrogen, Fosfor dan Kalium (NPK) Menggunakan Alumina Teraktivasi sebagai Material Pengisi Kolom, *ALCHEMY Jurnal Penelitian Kimia*, 16(2), 1-11.
- Some, I.T., Sakira, A.K., Mertens, D., Ronkart, S.N. & Kauffmann, J.M., (2016), Determination of groundwater mercury (II) content using a disposable gold modified screen printed carbon electrode, *Talanta*, 152, 335–340.
- Veronesi, F., Pontes, .M., Carneiro, M.C., Vaitsman, D.S., Monteiro, M.I.C., Neto, A.A., Tristão, M.L.B., & Guerrante, M.F., (2013), Comparative study of sample decomposition methods for the determination of total Hg in crude oil and related products, *Fuel Processing Technology*, 106, 122-126.
- Vicentino, P.O., Brum, D.M., & Cassella, R.J., (2015), Development of a Method for Total Hg Determination in Oil Samples by Cold Vapor Atomic Absorption Spectrometry After its Extraction Induced by Emulsion Breaking, *Talanta*, 132, 733–738.
- Wilhelm, S.M., (2011), Estimate of Mercury Emissions to the Atmosphere from Petroleum, *Environmental Science & Technology*, 35(24), 4704-4710.
- Zhu, S., Chen, B., He, M., Huang, T., & Hu, B., (2017), Speciation of mercury in water and fish samples by HPLC-ICP-MS after magnetic solid phase extraction, *Talanta*, 171, 213-219.



1. Corresponding author : Aman Sentosa Panggabean
2. Article title : Gas-liquid Separator Modified on CV-AAS System for Determination of total Hg in the Industrial wastewater Samples
3. Affiliation : Departmen of Chemistry, Universitas Mulawarman
4. email : amanspanggabean@yahoo.com

Statement and Copyright

I declare that the submitted article:

1. Plagiarism free.
2. **Have not been published or under consideration to publish elsewhere.**
3. Include the **supervisor / advisor** in the author list name if the article is part of thesis/dissertation.
4. Include the **student** in the author list if the research was performed by the supervised/advised student.
5. Agreed by all author mention in the author list, any conflict would be resolved internally among authors.
6. Copyright of final version article format is with the publisher of MOLEKUL.

Samarinda, 1 Nopember 2022,
Corresponding author,

(Aman Sentosa Panggabean)