

THE INFLUENCE OF CORPORATE SOCIAL RESPONSIBILITY ON CORPORATE IMAGE AND CORPORATE REPUTATION AND IMPLICATIONS FOR PURCHASE INTENTION (Studies in Samarinda AQUA customers)

Andi Irma Dinata¹⁾, Gusti Noorlitaria Achmad²⁾, Saida Zainurossalamia ZA³⁾

Faculty of Economics and Business, University of Mulawarman^{1),2),3)}

E-mail: andiirmadinata@gmail.com, gusti.noorlitaria.achmad@feb.unmul.ac.id,

saida.zainurossalamia.za@feb.unmul.ac.id

Abstract:

The purpose of this study was to determine the effect of CSR on corporate image, corporate reputation, and purchase intention. The unit of analysis in this study is the customer AQUA of product in Samarinda. The sample in this study was 120 respondents with accidental sampling with a sampling approach. Data were collected using a questionnaire distributed to respondents, and then analyzed using a questionnaire scale Linkert 5 and using product Static analysis tools and Service Solutions (SPSS) version 17 and Structural Equation Modeling (SEM) AMOS Version 22.

The analysis shows that CSR has a significant influence of the company's image, reputation of the company, and does not have a strong influence on purchase intention. Based on the results of data analysis found that the company's image and reputation of the company has a significant impact on purchase intention.

Keywords: CSR, Corporate Image, Corporate Reputation, and Purchase Intention

1. Introduction

A company that carries out its responsibilities as a successful company means that it has great concern for those who contribute to the sustainability of the company's business.

Many companies recognize the importance of social responsibility, and include social responsibility in the strategic issues of corporate business. Today, corporate social responsibility has become a kind of social license to operation (business license). In fact, it is not uncommon for companies to include social responsibility issues in the company's vision and mission. With the existence of CSR, it will give a positive impression on the product. This will make a brand more known and remembered, which forms an emotional bond in the minds of consumers, over time the emotional bond will develop and make a corporate image and corporate reputation and with a good corporate image and reputation it will have an impact on purchase intention, namely consumer purchase intention of product.

According to Kotler and Lee (2005), suggested that CSR which is implemented appropriately, both in the economic, social and environmental fields, will be able to provide many benefits for companies, one of them is being able to increase corporate image and also corporate reputation. The benefits that can be gained from the company's CSR accumulation are closely related to customers, including the creation of a positive customer attitude towards the company which will ultimately lead to the company's image and company reputation. With a good image or reputation from customers and society, it will have a positive effect on buying interest. Purchasing interest will be influenced by the company's image and reputation. According to Kotler and Lee (2005), argued that CSR which is implemented properly, both in the economic, social and

environmental fields, will be able to provide many benefits for the company, one of them is being able to improve corporate image and also corporate reputation. The benefits that can be gained from the company's CSR accumulation are closely related to customers, including the creation of a positive customer attitude towards the company which will ultimately lead to the company's image and company reputation. With a good image or reputation in the eyes of customers and society, it will have a positive effect on buying interest. Purchasing interest will be influenced by the company's image and reputation of the company.

Indicators for CSR (X1) in this study were adopted from Chalal and Sharma (2006), namely (1) Economic Dimensions, (2) Social Dimensions, (3) Environmental Dimensions.

According to Kotler and Armstrong (1992: 396) argues that: "Organizational image is the way an individual or a group views an organization". Indicators for Corporate Image (Y1) in this study were adopted from Fornell (1992), namely (1) Overall opinion on the company, (2) Opinion of the company's contribution to, (3) Like the company.

Basya and Sati. (2006: 6) Reveals that: Corporate Reputation or company reputation is a value given to individuals, institutions or countries. Reputation cannot be obtained in a short time because it must be built over many years to produce something that can be assessed by the public. Reputation will only survive and be sustainable if the words and actions are consistent.

Indicators for Corporate Reputation (Y2) in this study were adopted by Wang et al. (2005), namely:

(1) Customer perception, (2) Customer Comparison Perception, (3) Customer trust. According to Kotler, Bowen and Makens (1999: 156) regarding purchase intention: purchase interest arises after an alternative evaluation process exists and in the evaluation process, a person will make a series of choices regarding the product to be purchased on the basis of brand or interest. Indicators for Purchase Intention (Y3) in this study were adopted from Berman and Evans (2005), namely (1) stimulation, (2) awareness, (3) information seeking.

The formulation of the problem in this study are:

1. Does corporate social responsibility (CSR) affect the company's image on AQUA products?
2. Does corporate social responsibility (CSR) affect the company's reputation on AQUA products?
3. Does corporate social responsibility (CSR) affect the purchasing decisions of AQUA products?
4. Does the company image affect the AQUA product purchase decision?
5. Does the company's reputation affect the decision to purchase AQUA products?

2. Research Methods

This is a survey research, where data collection uses a questionnaire. A survey is a study that takes a sample from a population and is the main means of collecting data. The definition of survey is limited to the survey sample where a portion of the population is taken to represent the entire study. In this study, the population is consumers of mineral water products in AQUA brand packaging in Samarinda City. The criteria for the population of this study are all Samarinda people who have bought or even been loyal to use AQUA brand mineral water products. Sampling in this study using Cluster or Random Sampling and Accidental Sampling techniques. Accidental sampling is taking respondents as a sample based on chance without being designed to be aimed at certain previous respondents, namely anyone who happens to be met by the researcher and has the probability (possibility) of ever buying AQUA products then that respondent will be taken as the sample. Hair et al., (2010: 637) suggest that the appropriate sample size for SEM analysis tools is between 100-200 respondents with the intention that it can be used in estimating interpretations by SEM. In addition, determining the maximum sample size for SEM according to Hair et al. (2010: 637) is depending on the number of research indicators multiplied by 5 to 10. In this study there are 12 research indicators and using the multiplier number is 10, so the number of research samples is as follows:

$$\text{Total of samples} = 12 \times 10 = \mathbf{120} \text{ samples / respondent}$$

The variables observed in this study were four variables consisting of 1 exogenous and 2 intervening and 1 endogenous with 12 indicators, then by referring to the minimum sample size calculation, the number of samples selected for this study was 120 respondents.

3. Results and Discussion

3.1 Results

Based on the answers given by the respondents in this study, some of the criteria for the recipe can be explained is gender, age and income of the respondent.

Table 3.1
Gender

GENDER	TOTAL (PERSON)	PERCENTAGE (%)
MALE	51	42,5
FEMALE	69	57,5
TOTAL	120	100

Source : Calculated by author, 2020

In table 3.1 above, it can be seen that of the 120 respondents, the number of respondents who were mostly female respondents was 69 respondents.

Table 3.2
Respondents Data by Age

AGE (YEAR)	TOTAL (PERSON)	PERCENTAGE (%)
< 20	0	0
20 – 29	17	14,17
30 – 39	33	27,5
40 – 49	59	29,17
> 50	11	9,16
TOTAL	120	100

Source : Calculated by author, 2020

In table 3.2 above, it can be seen that of the 120 respondents the number of respondents was the dominant respondent aged 40 to 49 years, namely as many as 59 respondents.

Table 3.3
Respondents Data by Income

PENGHASILAN (Rp)	JUMLAH (ORANG)	PERSENTASE (%)
< 2 juta	13	10,83
2 juta - 4 juta	27	22,5
4 juta - 6 juta	33	27,5
> 6 juta	47	39,17
JUMLAH	120	100

Source: Primary data processed in 2020

In table 3.3 above, it can be seen that of the 120 respondents the number of respondents is the dominant respondent with an income of > Rp. 6,000,000 as many as 47 respondents.

3.2 Discussion

Validity and reliability are used to test instruments in the form of indicators and questions to meet the requirements or can be used as measurement variables. Validity and reliability tests were carried out on 120 respondents as a test which can be seen in the following table:

Table 3.4
Test Results of the Validity and Reliability of Research Instruments

Variabel	Indikator	Koefisien Korelasi (r)	Validitas	Alpha Cronbach (Reliabilitas)
CSR (X1)	X1.1	0.868	Valid	0.911 (Reliabel)
	X1.2	0.809	Valid	
	X1.3	0.899	Valid	
Corporate Image (Y1)	Y1.1	0.897	Valid	0.920 (Reliabel)
	Y1.2	0.884	Valid	
	Y1.3	0.831	Valid	
Corporate Reputation (Y2)	Y2.1	0.854	Valid	0.907 (Reliabel)
	Y2.2	0.847	Valid	
	Y2.3	0.862	Valid	
Purchase Intention (Y3)	Y3.1	0.757	Valid	0.825 (Reliabel)
	Y3.2	0.784	Valid	
	Y3.3	0.764	Valid	

Source: Primary data processed using SPSS, 2020

Table 3.4 above shows that the correlation coefficient (r) of each instrument used in the study is greater than 0.30 ($r > 0.30$). This shows that the research instrument is valid. Likewise, the Cronbach-Alpha value of each variable shows a number greater than 0.60, so it can be said that the research instrument is reliable. Thus the research instrument is suitable for data collection.

SEM Analyst Results

The results of the SEM analysis in the output in the form of a path diagram are presented in Figure 3.1 as follows:

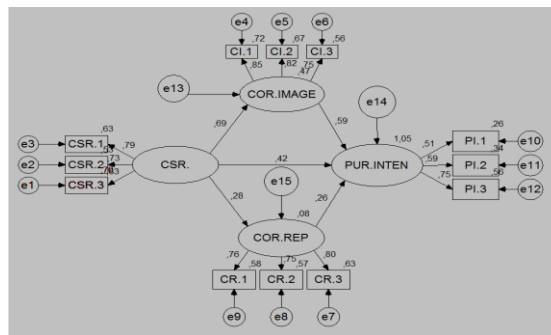

Picture 3.1

Sem Analysis Result Path Diagram

Source: Structural Equation Modeling (SEM) AMOS Version 22. (2020)

The complete fit model test results can be seen in the results of the SEM analysis. Briefly presented in Table 3.5 as follows:

Tabel 3.5
Goodness of Fit Overall Model Test Results

Kriteria	Cut-of value	Hasil Model	Keterangan
Khi Kuadrat	Kecil	118.7	Model Fit
p-value	≥ 0.05	000	Model Kurang Fit
CMIN / DF	≤ 2.00	2.422	Model Kurang Fit
GFI	≥ 0.90	0.863	Model Mendekati Fit
AGFI	≥ 0.90	0.782	Model Kurang Fit
TLI	≥ 0.95	0.864	Model Mendekati Fit
CFI	≥ 0.95	0.899	Model Mendekati Fit
RMSEA	≤ 0.08	0.109	Model Kurang Fit

Source: Primary data processed, 2020

The results of the fit model examiner in Table 3.5 show that of the seven criteria, there are 4 that indicate the model is less fit, and there are 3 models that are close to fit, namely the GFI, TLI, and CFI, but when viewed from the Chi-Square value it has met the cut value. off, then the model is considered fit and feasible to be used for hypothesis testing (Arbuckle and Wothke, 1999).

Hypothesis Testing Results

Hypothesis testing in this study was carried out by SEM analysis. Hypothesis testing is carried out on each direct influence path using the t-test, the results of which are presented in Table 3.6 below.

Tabel 3.6
Hypothesis Testing Results

Variabel	Koef. Jalur Standardize	C.R	Prob.	Keterangan
CSR (X1) -> Corporate Image (Y1)	0.688	6.580	***	Signifikan
CSR (X1) -> Corporate Reputation (Y2)	0.282	2.559	0.011	Signifikan
CSR (X1) -> Purchase Intention (Y3)	0.418	3.085	0.002	Signifikan
Corporate Image (Y1) -> Purchase Intention (Y3)	0.587	4.016	***	Signifikan
Corporate Reputation (Y2) -> Purchase Intention (Y3)	0.261	2.936	0.003	Signifikan

Source: Primary data processed, 2020

With the hypothesis that it has been formulated in the previous chapter, the results of testing the hypothesis table 3.6 can be summarized as follows:

H1: CSR has a significant effect on image. This can be seen from the positive sign path coefficient of 0.688 with a C.R value of 6.580 (see Table 3.6) and a significance probability (p) of 0.001 is obtained which is smaller than the significance level (α) which is determined at 0.05. Thus CSR (X1) has a significant effect on company image (Y1), which means that the right CSR (X1) will increase the level of corporate image (Y1). The higher the influence of CSR will improve the company's image.

H2: CSR has a significant effect on company reputation. This can be seen from the positive path coefficient of 0.282 with a C.R value of 2.559 (see Table 5.18) and a significance level of 0.011 is obtained which is smaller than the significance level (α) which is set at 0.05. Thus CSR (X1) has a significant effect on company reputation (Y2), which means that CSR activities will increase the company's reputation.

H3: CSR has a significant effect on buying interest. This can be seen from the positive sign path coefficient of 0.418 with a C.R value of 3.085 (see Table 5.18) and a significance (p) of 0.002 is obtained which is greater than the significance level (α) which is determined at 0.05. Thus, CSR (X1) has a significant effect on buying interest (Y3), which means that CSR activities (X1) will directly increase the level of purchase interest (Y3). The higher the influence of CSR, can make customers directly interested in buying these products.

H4: Company image has a significant effect on purchase intention. This can be seen from the positive sign path coefficient of 0.587 with a CR value of 4.016 (see Table 5.18) and a significance (p) of 0.001 is obtained which is smaller than the significance level (α) which is determined at 0.05. Thus, company image (Y1) has a significant effect on buying interest (Y3), which means that an increase in company image (Y1) will increase the level of buying interest (Y3). The influence of the higher corporate image will make customers interested in buying the product.

H5: The company's reputation has a significant effect on buying interest. This can be seen from the positive sign path coefficient of 0.261 with a value of C. R 2.936 (see Table 5.18) and a significance probability (p) of 0.003 is obtained which is smaller than the significance level (α) which is determined at 0.05. Thus the company's reputation (Y2) has a significant effect on purchase intention (Y3), which means that a good company reputation will increase customer purchase interest.

4. Conclusion

Based on the analysis and discussion, it can be concluded as follows:

CSR has a significant effect on Corporate Image with a positive relationship direction. This means that the right CSR activities will raise the level of Corporate Image. CSR has a significant effect on corporate reputation with a positive relationship direction. This means that the right CSR activities will give a positive value to the reputation of a company which will increase customer buying interest.

CSR has a significant effect on purchase intention with a positive relationship direction and can be said to be significant according to the predetermined significant value. This means that the CSR activities carried out provide positive results that will affect customer buying interest in these products.

Corporate Image has a significant effect on purchase intention with a positive relationship direction. This means that a good Corporate Image will increase the level of Purchase intention. Corporate Reputation has a significant effect on purchase intention with a positive relationship direction. This means that a good reputation will increase customer interest in buying.

5. Suggestions

Based on the analysis, discussion and conclusions that have been put forward in this study, it can be recommended: The right CSR will increase the positive image for the company. It is recommended that AQUA management keep improving CSR because this variable is proven to increase the company's image. Correct CSR will improve the company's reputation. It is recommended that AQUA management maintain its existing CSR program because this variable has been proven to increase the company's reputation. Existing CSR programs are quite influential in buying interest in products. It is recommended that AQUA management further improve the CSR program to increase customer buying interest in AQUA products. A positive corporate image will increase customer buying interest. It is recommended that AQUA management continue to improve the company's image because this variable is proven to be able to increase the interest in buying AQUA products. A good company reputation will increase the customer's buying interest. It is recommended that AQUA management continue to improve the reputation of the company that has been owned because this variable has been proven to increase the interest in buying AQUA products.

Reference:

- Ali and Jawaria Fatima Ali (2014) "Corporate social responsibility, corporate reputation and employee engagement" Munich Personal RePEc Archive.
- Cheng and Ping Chang (2009) "The relationships among corporate social responsibility, corporate image and economic performance of high-tech industries in Taiwan". Institution of Technological and Vocational Education and Human Resource Development, Southern Taiwan University of Technology, Tai Pei City, Taiwan.
- Chun-Chen Huang et al (2014) "The relationship among Corporate Social Responsibility, Service Quality, Corporate Image and Purchase Intention". The International Journal of Organizational Innovation Vol 6 Num 3 January 2014.
- Fombrun, Charles J. (1996) Reputation: Realizing Value from The Corporate Image.
- Hair, J., J. F., Black, W. C., Babin, B. J., Anderson, R. E., & Tatham, R. L. (2010). Multivariate Data Analysis (7th ed.). Upper Saddle River, NJ: Pearson Prentice Hall.
- Kotler, P., & Armstrong, G. (2018). Principles of Marketing (17th ed.). United States: Pearson Education.
- Kotler, P., & Keller, K. L. (2015). Marketing Management 15 / e. Prentice Hall. London: Pearson Education, In <https://doi.org/10.1177/1060028014534195>
- Kotler, P. & Lee, N. (2005). Corporate social responsibility: Doing the most good for your company and your cause. New Jersey: John Wiley & Son, Inc.
- Lucia Gatti et. al (2012) with the title "The role of corporate social responsibility, perceived quality and corporate reputation on purchase intention: Implications for brand management" 2012 Macmillan Publishers Ltd. 1350-23IX Journal of Brand Management Vol. 20, 1, 65–76
- Sang Back Nam and Kwang Yong Lee (2013) "The Influence on The Paralympic Sponsorship on Consumer Purchase Intention"
- Zulhamri Abdullah and Yuhanis Abdul Aziz (2013) "Institutionalizing corporate social responsibility: effects on corporate reputation, culture, and legitimacy in Malaysia" VOL. 9 NO. 3 2013, pp. 344-361, Q Emerald Group Publishing Limited, ISSN 1747-11