



# the 5<sup>th</sup> ICTROPS

International Conference  
for Tropical Studies and Its Applications

**“The Bridging of Multidisciplinary Trends  
Between Social and Life Science  
on Tropical Studies: Beyond Covid-19 Pandemic”**

# PROCEEDING BOOK

**6<sup>th</sup> October 2021 | Samarinda-Indonesia**

[ictrops-idb.unmul.ac.id](http://ictrops-idb.unmul.ac.id)

Organized By :



Islamic Development Bank 4in1 Project  
Project Implementation Unit  
Mulawarman University

Co-Organized By :



# **Proceeding 5<sup>th</sup> ICTROPS 2021**

## **The 5<sup>th</sup> International Conference on Tropical Studies and Its Applications**

The Bridging on the Trend of Multidisciplinary Between Social and Life Science  
on Tropical Studies: Beyond Covid-19 Pandemi

Samarinda, 6 October 2021



**Penerbit**

Mulawarman University Press

**Redaksi**

Gedung A20 Lembaga Penelitian dan Pengabdian

Masyarakat (LP2M) Universitas Mulawarman

Jl. Krayan, Kampus Gn. Kelua Samarinda, Kalimantan Timur

**HAK CIPTA DILINDUNGI UNDANG-UNDANG.**

**Dilarang keras menerjemahkan, menyalin, atau memperbanyak sebagian atau seluruh isi buku ini tanpa izin tertulis dari pemegang hak cipta.**

# **Proceeding 5<sup>th</sup> ICTROPS**

The 5<sup>th</sup> International Conference on Tropical Studies and Its Applications  
“The Bridging on the Trend of Multidisciplinary Between Social and Life Science  
on Tropical Studies: Beyond Covid-19 Pandemi”  
”

## **Editor dan Layout**

Fahrizal Adnan

## **Desain Cover**

Muhammad Bambang Firdaus

## **Comittee:**

### **Honorary Board**

Prof. Dr. H. Masjaya, M.Si

Prof. Dr. Ir. Mustofa Agung Sardjono

Dr. Bohari Yusuf, M.Si

Prof. Dr. Enos Tangke Arung, S.Hut

Dr. Anton Rahmadi, M.Sc

### **Steering Committee:**

Dr. Zeni Haryanto, M.Pd

### **Director**

Dr. Sc. Mustaid Yusuf, M.Sc

### **Chairman**

Nurul fitriyah Sulaeman, Ph.D

### **Co-Chairman**

Kadis Mujiono, Ph.D.

### **Secretary**

Agustu Sholeh Pujokaroni, Ph.D.

### **Co-Secretary**

Alamsyah Tawakkal, Ph.D.

### **Treasurer**

Dr. Nova Hariani, S.Si, M.Si

### **Reviewer**

Dewi Embong Bulan, Ph.D.

Agustu Sholeh Pujokaroni, Ph.D.

Ritbey Ruga, Ph.D.

Alamsyah Tawakkal, Ph.D.

Nurul fitriyah Sulaeman, Ph.D

### **ISBN:**

## Foreword of Rector

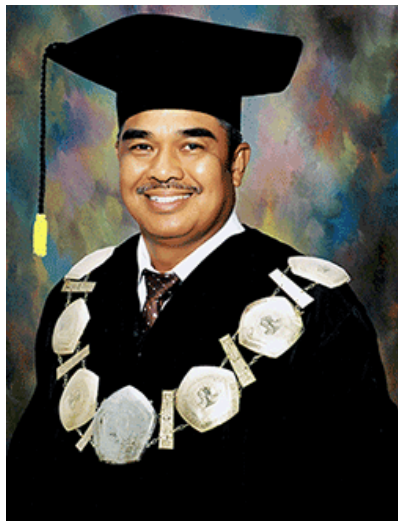

Assalamualaikum Wr. Wb.

Dear colleagues, professors, lecturers, researchers, and all participants.

On behalf of Mulawarman University, I would like to express my sincere gratitude and welcome you to the 5<sup>th</sup> ICTROPS 2021. Moreover, I honourably welcome our keynote speakers

- Dr. Awang Azman Bin Awang Pawi, University of Malaya, Malaysia
- Dr. Suthirat Kittipongvises, Chulalongkorn University, Thailand
- Prof. Yoshisuke Kumano, Shizuoka University, Japan
- Dr. Maria-Laura Franco-Garcia, University of Twente, Netherlands

Executive directors of PMU (Project Management Unit), and PIU (Project Implementation Unit) 4in1 IsDB projects, and our invited speakers.

### Ladies and Gentlemen and All The Audiences

I hope that the conference would be able to achieve its objective in providing a platform for researchers and practitioners to advancing knowledge and research for the better of life beyond the pandemic. The center of excellence of our

university is Tropical studies. Therefore, this conference is a forum for sharing the latest issues in the context of tropical studies and its applications. We realized that the complexity of these issues needs a balanced from the pure science and social science perspectives.

### Ladies and Gentlemen and All The Audiences

Finally, my deepest gratitude goes to the Advisory Board, Organizing Committee, PMU and PIU 4in1 IsdB projects (the University of Jember, State University of Malang, and Sultan Agung Tirtayasa University) who have supported the success of this conference. The committee has organized a scientific program and is working hard to present highly respected and international speakers to lead it. Although we try our finest to be professional, please accept our sincere apologies should some inconveniences occur before, during, or after the event. I wish you a very productive conference with exciting and encouraging discussions and exchanges of knowledge.

Thank you for joining this event. I sincerely hope you will enjoy our conference. By saying BISMILLAHIROHMANI RAHIM, I OFFICIALLY OPEN THIS 5<sup>TH</sup> ICNTROPS INTERNATIONAL CONFERENCE 2021

Rector of Mulawarman University  
Prof. Dr. H. Masjaya, M.Si

## Foreword of Executive Director of PIU-IsDB



Assalamu 'alaikum wr wb.

The important role of this IsDB project is as an enabler for Mulawarman University to achieve as a Service Excellence on Center for Tropical Studies (SE-CTS) by developing five key sectors namely Campus Infrastructure (CI), Teaching and Learning (T&L), Research, on Campus Service (CS), and Public Services (PS). The project will indirectly benefit GDP of the nation as a result of higher quality of education. It is expected that the project will increase the quality of graduates, both in academic skills as the core competence and soft skills as an essential added value. It is projected that the project becomes an important trajectory for qualified human resources that are heavily in need to face the embracing ASEAN Economic Community and possibly Trans Pacific Partnerships. Samarinda as the host city for Mulawarman University and East

Kalimantan province will also economically benefited through the coming of more young researchers.

The International Conference on Tropical Studies and Its Application annual conference on 6<sup>th</sup> October 2021, is organized by Mulawarman University in collaboration with Islamic Development Bank (IsDB) and Ministry of Research, Technology, and Higher Education of The Republic of Indonesia. On behalf of Project Implementation unit (PIU) Islamic Development Bank (IsDB) of Mulawarman University, We would also like to extend our gratitude especially to all speakers, participants and committees.

Wassalamu'alaikum wr. wb.

Executive Director of PIU-IsDB.  
Dr. Sc. Mustaid Yusuf, M.Si.

## Foreword from the Chairman of Organizing Committee



Agung Tirtayasa University.

Assalamualaikum Wr. Wb.

Dear honourable Rector of Mulawarman University, Director of PMU and PIU IsDB 4in1 Project, Professors, Lecturers, Researchers, and all Participants. The 5th International Conference on Tropical Studies and Its Application (ICTROPS) 2021 was held on October 5 – 6, 2021, in Mulawarman University, Samarinda, Indonesia. Our conference is organized by Mulawarman University in collaboration with Islamic Development Bank (IsDB) 4in1 project, which also involves the University of Jember, State University of Malang, and Sultan

Agung Tirtayasa University. On behalf of the organizing committee, we hope that the 5th ICTROPS provided a warm platform for collaboration and communication in tropical studies and its application. Realizing our situation during the COVID-19 pandemic and the need for multidisciplinary perspectives on tropical studies, the conference's theme is **"The bridging on the trend of multidisciplinary between social and life science on tropical studies: beyond covid-19 pandemic"**. Our conference had four main activities: General Lecture session, Keynote Speaker session, Invited Speaker session, and Parallel session held through online platform. Through all the activities, we hope the conference could contribute to the latest issues in the tropical studies field.

We invited the six distinguished experts who became our Keynote speakers. For the general lecture session, Prof. Ida Bagus Andika from Qingdao Agricultural University China and Dr. Endra Gunawan, S.T., M.Sc. from Institut Teknologi Bandung, Indonesia, delivered the lectures about scientific writing. For the conference session, Dr. Awang Azman Bin Awang Pawi, University of Malaya, Malaysia; Prof. Yoshisuke Kumano from Shizuoka University, Japan; Dr. Suthirat Kittipongvises, Chulalongkorn University, Thailand; and Dr. Maria-Laura Franco-Garcia, University of Twente, Netherlands, shared their expertise. The invited speakers session, Tubagus Bahtiar Rusbana, Ph.D, Sultan Agung Tirtayasa University, Indonesia; Eli Hendrik Sanjaya, Ph.D, University of Malang, Indonesia; Pramudya Dwi Aristya Putra, Ph.D, University of Jember, Indonesia; Ronny Isnuwardhana, Ph.D from Mulawarman University shared their latest research. All of the invited speakers are the awardee of IsDB scholarship, which successfully finished their study. We also received papers from colleagues in Indonesia, Malaysia, Japan, and Sudan for the parallel session.

Finally, our deepest gratitude goes to the Advisory Board, all Organizing Committee, PMU and PIU 4in1 IsDB projects (University of Jember, State University of Malang, and Sultan Agung Tirtayasa University) and also all moderators who have supported the success of this conference.

**Chair of Organizing Committee**  
**Nurul Fitriyah Sulaeman, Ph.D**

## Committee

Steering Committee	: Prof. Dr. H. Masjaya, M.Si Prof. Dr. Ir. Mustofa Agung Sardjono Dr. Ir. Bohari Yusuf, M.Si Dr. Sc, Mustaid Yusuf, M.Si Anton Rahmadi, Ph.D
Program In Charge	: Dr. Zeni Haryanto, M.Pd
Chairman	: Nurul Fitriyah Sulaeman, Ph.D
Vice Chairman	: Kadis Mujjiono, S.P., M.Sc., Ph.D
Secretary	: Agustu Sholeh Pujokaroni, Ph.D
Vice Secretary	: Alamsyah Tawakkal, S.Pd., M.Pd., Ph.D
Treasurer	: Dr. Nova Hariani, S, Si., M.Si
Finance	: Hj. Dini Mariani, SE.,M.Si Yuliandini Puspita, S.TP Masykur Kurniawan, S.E
Event	: Ir. Novianti Puspitasari, S. Kom, M. Eng Muhammad Bambang Firdaus, M.Kom. Dr. Anindita Septiarini, ST., M. Cs Masna Wati, S. Si., MT Heliza Rahmania Hatta, S. Kom., M. Kom Joan Angelina Widiangs, S.Kom, M.Kom Roni Isnuwardana, dr., Ph.D Zhafira Kurnia Fitri, S.IP Firdan Fahrizal, S.IP
IT	: Reza Maulana Yusuf, S.Kom Rusfina Widayati, ST, M.Sc Agung Yusuf, S, Sos Dedy Cahyadi, M.Eng Indra Hendriawan, SP., MP. Dian Noor Arthady Wijaya, SP Firman, S.Kom
Proceeding	: Fahrizal Adnan, ST., M.Sc. Ritbey Ruga, Ph.D Suhardi., S. Pt., M.P., Ph.D Dewi Embong Bulan, Ph.D Addy Suyatno, M. Kom Andi Mismawati, S.Pd, M.Sc Lisa Agustina, S.T
Logistics	: Risa Nova Purwandari, S.Si Rizky Maulida Amalia Hanif, S.Si



## Content

Foreword of Rector .....	iv
Foreword of Executive Director of PIU-IsDB .....	v
Foreword from the Chairman of Organizing Committee .....	vi
Committee .....	vii
Content .....	viii
Venue .....	x
Keynote Speakers .....	xi
Invited Speakers .....	xiii
Schedule .....	xiv
Parallel Session .....	xv
Biological Waste and Waswater Treatment Technology in Tropical Countries .....	1
SEE-411 Analysis of the Impact of the Covid-19 Pandemic on the Coal Mining Industry Sector At Pt. Jhonlin Baratama Site Lolo, Js Group Paser Regency .....	1
SEE-412 The Impact of Covid 19 on Street Vendors in the Scout Street Area of Samarinda City .....	7
SEE-418 Teacher Self-Efficacy for Professional Development during the COVID-19 Pandemic in East Kalimantan .....	12
SEE-419 Analysis of Health Level In Infants And Toddlers In The Midst Covid-19 Pandemic In Petung Sub-District, Penajam Paser Utara Region: Social And Health Phenomenon .....	19
SEE-425 Exploring Pre-service Teachers Trust in Science-Technology-Engineering-Mathematics (STEM) during the COVID-19 Pandemic .....	25
SEE-427 COVID-19 Impact towards Domestic Immigrant Worker in Malaysia: CaseStudy in Petaling .....	32
SEE-430 Exploring Science and Engineering Practices in Indonesian Physics Textbook about Heat and Temperature .....	39
SEE-437 Power Generation Potential Based On Wind Speed Variations In Wind Power Plant Prototypes ....	45
SEE-454 The Urgency of Tropical Studies Based Social Entrepreneurship in the Covid 19 Period .....	53
SEE-462 Association Analysis of the Number of Dengue Hemorrhagic Fever Cases in East Kalimantan with the Factors of Geographic, Demographic, and Health Using Spearman Rank Correlation .....	57
SEE-469 Added Value Analysis of <i>Eleutherine americana</i> M. Herbal Tea Mursidah * .....	64
SEE-487 Economic Empowerment of the Muang Ilir Village Community Through “MILTOVIL” (Muang Ilir Ecotourism Village) .....	71
TCBD-431 Microteaching for Pre-service Science Teachers during the COVID-19 Pandemic: A Theoretical Framework .....	80
TCBD-483 Computational Intelligent Algorithms in Multi-Sensor Data Fusion for UAV Detection and Identification: Challenges and Opportunities .....	86
TEE-416 Geographical Risk Factors of Strongyloides stercoralis infection in East Kalimantan Province, Indonesia .....	96
TEE-421 Comparison of Content and Status of the C-Organic, Nitrogen, C/N Ratio, Soil pH, and Organic	

Matter in Rainfed, Tidal and Swampy Rice Fields (Case Study in Three Villages, in East Kalimantan) .....	106
TEE-423 Essential Ecological Risk Factors of Strongyloides stercoralis infection in Rural Areas Kutai Kertanegara, Indonesia .....	114
TEE-436 Association of Endophytic Fungi in Rice Root ( <i>Oryza sativa L</i> ) .....	125
TEE-444 Effect of UVA, UVC, UVA/TiO <sub>2</sub> , and UVC/TiO <sub>2</sub> for Degrading Synthetic Dyes.....	135
TEE-450 Diagnose Digestive Disease and the Selection of Borneo Medicinal Plants as an Alternative Treatment .....	143
TEE-451 Pollinator-friendly plants for supporting pollinator insect conservation on agroforestry in Jatiarjo, Prigen, East Java .....	151
TEE-453 Degradation of Methylene Blue using TiO <sub>2</sub> /UVC Photocatalyst and Role of Scavengers .....	164
TEE-468 Association of Endophytic Fungi In Rice Root ( <i>Oryza sativa L</i> ).....	171
TEE-484 Fauna Exploration and Inventory in the Mount Kelua Fkip Campus Area, Mulawarman University .....	180
TEE-028 Supplier Selection Using AHP dan TOPSIS: a Case Study in The Bakery .....	188
TNP-422 Hemagglutinins Inhibitors from Tropical Medicinal Plants Used in Sudan.....	197
TNP-429 Crystal Structure, Mineral Content, $\beta$ -Carotene, $\alpha$ -Tocopherol, Antioxidant and Functional Group Active of Pre-gelatinization and Pre-Digest White and Red Rice Flour from East Kalimantan as Source of Anti-Stunting Nutrients .....	205
TNP-435 Green Synthesis of Silver Nanoparticles From Soursop Leaf Extract ( <i>Annona Muricata Linn.</i> ) ...	210
TNP-439 Prototype of Automatic System DC Fan Speed Based by Microcontroller, and Connected to Blynk (Internet of Things) .....	215
TNP-442 Potential of Nutraceutical Gummy Candy from Kepok Banana Peel Extract ( <i>Musa paradisiaca Linn.</i> ) in Combination with Kelulut Honey ( <i>Trigona incisa</i> ) as a Covid-19 Supportive Therapy .....	222
TNP-445 Phytochemical Analysis of Ethanol Extract from Stingless Bee ( <i>Tetragonula laeviceps Smith</i> ) Honey and Its Anti-Acnes Activity .....	232
TNP-452 Prototype of Smart Trash bin based by Microcontroller with Telegram communication .....	239
TNP-457 Purun Plant in East Kalimantan, The Endemic Plants in Peat and Swamp Areas as A Humid Tropical Local Commodity with Superior Potential.....	250
TNP-478 Utilization of Goat Manure Towards PLTB (Biogas) Prototypes in Simple Way.....	255



the 5<sup>th</sup> **ICTROPS**

International Conference  
for Tropical Studies and Its Applications

Islamic Development Bank 4in1 Project  
Project Implementation Unit  
University of Mulawarman



ISDB  
البنك الإسلامي للتنمية  
Islamic Development Bank

Co-Organized by :



## Venue



Zoom Meeting

(Meeting ID: 976 4542 1452 Passcode: ICTROPS)

<https://unmul.zoom.us/j/97645421452?pwd=TIIVNlp0ZTk3akNwSXF6cVR1RXozdz09>

## Keynote Speakers



### Associate Professor Dr Awang Azman bin Awang Pawi

Associate Professor Dr Awang Azman Awang Pawi is a lecturer at the Department of Socioculture and Arts, Academy of Malay Studies, University of Malaya. He is also a research fellow at the Center for the Study of Democracy and Elections Malaysia (UMCEDEL), besides being appointed as a *Distinguished Scholar* at the Pahang Al-Sultan Abdullah Center for the Study of History and Civilization. His field of study is applied Malay Studies. He has done a lot of research and became a consultant in the field of Malay socio-cultural, heritage, literature and politics. His research on the Malay world covers Indonesia, Thailand, Brunei, Singapore, the Philippines. He has been a visiting scholar at Leiden University, Netherland and Oriental Institute, Prague, Czechia. Apart from being a conference member of the UMCEDEL journal, the World Journal of Malay Studies, he is also an editorial member of the Malaysian Parliamentary Journal. Among his latest

books are *Identiti Muhammad Haji Salleh* (DBP, 2022) and *Budaya Politik Harian Sarawak* (UMPress, 2018). He is also a columnist for the *Sin Chew Daily* newspaper.



### Assistant Professor Suthirat Kittipongvises

Assistant Professor Suthirat Kittipongvises is currently a lecturer at Environmental Research Institute, Chulalongkorn University (ERIC) and also Director of Environment Development and Sustainability (International Program), Chulalongkorn University, Thailand. She received Ph.D. degree in Sustainability Science from the Graduate Program in Sustainability Science, Graduate School of Frontier Sciences, the University of Tokyo, Japan in 2013. She also earned master degree on Environmental Engineering and Management, Asian Institute of Technology (AIT), Thailand. Her research focuses on environmental sustainability, climate change mitigation, GHG quantification, climate change impacts and natural resources management, waste-to-energy, low carbon society, disaster management, flood risk perception, carbon capture and storage, ecological resilience and sustainability, environmental concerns, and worldviews and so on. She has

published both international journals with ISI/Scopus index in the areas of environmental management, climate change mitigation, urban GHG inventory, multi-hazards management and also book chapters on the following topics: Contextualizing the relationship between climate change perception and proactive actions: Thailand as a case study (Spears Media Press, Colorado, U.S), GHGs Emissions and Sustainable Solid Waste Management (Springer), and Constructed wetlands and waste stabilization ponds (Oxford Academic Press.)



the 5<sup>th</sup> **ICTROPS**

International Conference  
for Tropical Studies and Its Applications

Islamic Development Bank 4in1 Project  
Project Implementation Unit  
University of Mulawarman



ISDB  
البنك الإسلامي للتنمية  
Islamic Development Bank



**Prof. Yoshisuke Kumano, Shizuoka University, Japan**

- Professor Emeritus, Appointed Professor, Shizuoka University
- Professor of Science Education, Graduate School of Science & Technology (Ph.D. Program), Informatic Section, Graduate School of Education, Faculty of Education, Shizuoka University (from 2005-to 2021.3)
- Visiting Scholar at the University of Iowa (2012, September – 2012 December, Fulbright Scholar)
- Associate Professor of Science Education, Shizuoka University (1995-2005)
- Lecturer of Science Education, Shizuoka University (1993-1995)
- Meikei High School, Chair of Science Education (from 1981 to 1989), Chair of International Education (1991 to 1993)

Prof. Yoshisuke Kumano currently is the Professor of Science Education, Graduate School of Science & Technology, and Graduate School of Education, Shizuoka

University. Yoshisuke does research in Innovation of Science Education. Their current project is 'Shizuoka STEM Academy'. His academic background are Science Education, Geology, Paleontology, Earth & Space Science. He got Ph.D. in Science Education at the University of Iowa and Academic Mentor was Prof. Robert E. Yager in 1993 by the support of Fulbright Program.



**Dr. Maria-Laura Franco-Garcia, University of Twente, Netherlands**

Experience on topics associated to environmental management systems (Corporate Social Responsibility), Circular Economy at meso level (industrial parks) and macro level (circular cities).

María-Laura Franco-García holds a Ph.D. on “Environmental Chemistry” (Université Claude Bernard Lyon I, France). She worked for the Mexican Environmental Ministry contributing to the hazardous waste regulations. Franco’s research interests expanded to public and private management of natural resources and to product development fields since her affiliation to “Tecnológico de Monterrey”. Franco is currently one of the European coordinators of the global network of “Greening of Industry Network GIN” [www.greeningofindustry.org](http://www.greeningofindustry.org). Her current research is related to GIN’s mission, e.g. Circular Economy, CSR, sustainable industrial parks, social and

environmental Life Cycle Assessment, social entrepreneurship, among others.

## Invited Speakers

### **Tubagus Bahtiar Rusbana, Ph.D., Sultan Ageng Tirtayasa University, Indonesia**



Education:

- Bachelor in Agriculture Technology, IPB University (2003)
- Master of Science, IPB University (2009)
- Doctor of Philosophy, Tohoku University, Japan (2020)

Research:

Agriculture

### **Ronny Isnuwardana, dr., Ph.D., Mulawarman University, Indonesia**



Education:

- Doctor of Philosophy in Clinical Epidemiology, Faculty of Medicine Ramathibodi Hospital, Mahidol University, Thailand, 2021
- Master of International Health, Faculty of Medicine, Nursing and Health Sciences, Monash University, Australia, 2009
- Doctor of Medicine, Bachelor of Medicine, Bachelor of Surgery, Faculty of Medicine, Brawijaya University, Indonesia, 2002

Research:

Clinical epidemiology, biostatistics, global health

### **Eli Hendrik Sanjaya, Ph.D., State University of Malang, Indonesia**



Education:

- Bachelor of Chemistry, Universitas Negeri Malang (UM), Indonesia
- Master of Chemistry-Biochemistry, Institut Teknologi Bandung (ITB), Indonesia
- Doctor of Philosophy, Environmental Engineering, Tohoku University, Japan

Research:

Biochemistry, microbiology, metabolism, environmental management, environmental bioremediation

### **Pramudya Dwi Aristya Putra, Ph.D., University of Jember, Indonesia**



Education:

- Bachelor in Physics Education, Surabaya State University (2005 – 2009)
- Master of Science in Science Education, Sebelas Maret University (2010 – 2012)
- Ph.D in STEM Education, Shizuoka University, Japan (2017 – 2020)

Research:

Science Education

## Schedule

Time (GMT+8/ WITA)	Conference (6 <sup>th</sup> October, 2021)
08.00 – 08.15	Log in To Zoom Meeting (Meeting ID: 976 4542 1452 Passcode: ICTROPS) <a href="https://unmul.zoom.us/j/97645421452?pwd=TIIVNlp0ZTk3akNwSXF6cVRlRXozdz09">https://unmul.zoom.us/j/97645421452?pwd=TIIVNlp0ZTk3akNwSXF6cVRlRXozdz09</a>
08.15 – 08.35	Opening 1. The National Anthem of Republic Indonesia “Indonesia Raya” and Mars UNMUL 2. Prayer
08.35 – 08.45	Opening Speech by Executive Director of PMU ISDB 4 in 1 Project: Dr.rer.nat Suseno Amien
08.45 – 08.55	Opening Speech by Rector Mulawarman University: Prof. Dr.H. Masjaya, M. Si
08.55 – 09.00	Photo Session
09.05 – 09.45	Keynote Speakers Session 1 Dr. Awang Azman Bin Awang Pawi, University of Malaya, Malaysia <b>The Role of Social Sciences and Humanities Under Covid-19</b> Moderator: Alamsyah Tawakkal, Ph.D
09.50 – 10.30	Keynote Speakers Session 2 Dr. Suthirat Kittipongvises, Chulalongkorn University, Thailand <b>Air Quality Management and Sustainability Challenges</b> Moderator: Etik Sulistiowati Ningsih, Ph.D
10.35 – 11.15	Keynote Speakers Session 3 Prof. Yoshisuke Kumano, Shizuoka University, Japan <b>STEAM For SDGs; Great Needs on the Collaboration: Theory and Practices From Japan</b> Moderator: Nurul Fitriyah Sulaeman, Ph.D
11.15 – 11.55	Invited Speakers Session 1 1. Tubagus Bahtiar Rusbana, Ph.D., Sultan Ageng Tirtayasa University, Indonesia 2. Ronny Isnuwardana, Ph.D., Mulawarman University, Indonesia Moderator: Ritbey Ruga, Ph.D
11.55 – 12.35	Invited Speakers Session 2 1. Eli Hendrik Sanjaya, Ph.D., State University of Malang, Indonesia 2. Pramudya Dwi Aristya Putra, Ph.D., SUniversity of Jember, Indonesia Moderator: Sopialena, Ph.D
12.35 – 13.15	<b>Lunch Break</b>
13.15 – 13.20	Preparation
13.20 – 14.00	Keynote Speakers Session 4 Dr. Maria-Laura Franco-Garcia, University of Twente, Netherlands <b>How can manure’s nutritional value contribute to circular economy?</b> Moderator: Ir. Juli Nurdiana, MSc
14.00 – 16.00	<b>Parallel Session</b>
16.00 – 16.10	<b>Break Time</b>
16.10 – 17.10	Awarding + Closing Ceremony Closing Speech by The Executive Director of IDB UNMUL : Dr. Sc. Mustaid Yusuf, M.Si

## Parallel Session

Time	Room 1	Room 2	Room 3	Room 4	Room 5
14.00-14.10	SEE-411	TEE-414	TEE-450	TNP-422	TCBD- 475
14.10-14.20	SEE-412	TEE-417	TEE-444	TNP-424	TCBD- 483
14.20-14.30	SEE-419	TEE-416	TEE-453	TNP-429	SEE-469
14.30-14.40	SEE-418	TEE-421	TEE-451	TNP-435	SEE-474
14.40-14.50	SEE-427	TEE-423	TEE-459	TNP-442	SEE-481
14.50-15.00	SEE-425	TEE-433	TEE-456	TNP-439	TNP-480
15.00-15.10	SEE-430	TEE-468	TEE-464	TNP-445	TNP-477
15.10-15.20	SEE-437	TEE-441	TEE-465	TNP-457	SEE-487
15.20-15.30	SEE-462	TEE-446	TEE-466	TNP-452	SEE-449
15.30-15.40	SEE-455	TEE-458	TEE-467	TNP-471	TCBD-431
15.40-15.50	SEE-479	TEE-484	TEE-027	TNP-478	SEE-491
15.50-16.00	SEE-492		TEE-028		SEE-454

Room	Moderator 1	Moderator 2
1	Sukemi, S.Pd, M.Sc.	Ronny Isnuwardana, dr., MIH., Ph.D
2	Nur Rohmah, S.KM, M.Kes	Helda Niawati, S.T., M.T
3	Suhardi, S.Pt., M.P., Ph.D	Ari Wibowo, S.Pt, M.Si, Ph.D
4	Agustu Sholeh Pujokaroni, Ph.D	Andi Mismawati, S.Pd., M.Sc
5	Atin Nuryadin, S.Pd., M.Si., Ph.D	Galih Yudha Saputra, S.Kom., M.Kom.

### Notes

*Every presenter will have a 10 min presentation*

### Subtopic:

1. TEE = Tropical ecosystem and environment
2. TNP = Tropical natural products
3. TCBD = Territorial and communal based development in harmony with environments
4. SEE = Social and economic empowerment to support environmental literacy

**Display Name** in zoom is mandatory using the format we provided.

The format is: Sub Topic\_ID\_Room\_Name

For example Blego Sudionoto, Sub topic SEE, author paper ID number 416, Room 1

Display name : **SEE\_416\_1\_Blego Sudionoto**





the 5<sup>th</sup> **ICTROPS**

International Conference  
for Tropical Studies and Its Applications

Islamic Development Bank 4in1 Project  
Project Implementation Unit  
University of Mulawarman



IsDB  
البنك الإسلامي للتنمية  
Islamic Development Bank



No	ID	Subtopic	Authors	Title
1	411	SEE	Edwardus Iwantri Goma, Mei Vita R Ningrum, Adit Nur Pratama, Risma Amelia, Rita Wulandari, Umi Kholifatus Saniah, Yulia Sunarti	Analysis of the Impact of the Covid-19 Pandemic on the Coal Mining Industry Sector At Pt. Jhonlin Baratama Site Lolo, Js Group Paser Regency
2	412	SEE	Edwardus Iwantri Goma, Mei Vita R Ningrum, Muh. Ashar, Nur Halizah, Reni Novita, Yudi Suherman, Zaitun Alia A. Sanusi	The Impact of Covid 19 on Street Vendors in the Scout Street Area of Samarinda City
3	418	SEE	suryaningsi - suryaningsi	Teacher Self-Efficacy for Professional Development during the COVID-19 Pandemic In East Kalimantan
4	419	SEE	Anggriya Feby Setyowati	Analysis Of Health Level In Infants And Toddlers In The Midst Covid-19 Pandemic In Petung Sub-District, Penajam Paser Utara Region: Social And Health Phenomenon
5	425	SEE	Nurul Fitriyah Sulaeman, Lola Jovita, Riski Amalia, Shelly Efwinda	Exploring Pre-service Science Teachers Trust in Science-Technology-Engineering-Mathematics (STEM) during the COVID-19 Pandemic
6	427	SEE	Nurul Asmaa Akmal binti Md Din, Awang Azman bin Awang Pawi Rosila Bee Mohd Hussain	COVID-19 Impact towards Domestic Immigrant Worker in Malaysia: Case Study in Petaling
7	430	SEE	Septyani Triwulandari, Roro Dinda althaf Farah Zayyan Azizah, Muliati Syam, Pramudya Dwiariesty Putra, Nurul Fitriyah Sulaeman	Exploring Science and Engineering Practices in Indonesian Physics Textbook About Heat and Temperature
8	437	SEE	Agung Tandiminanga Tandiminanga	Utilization of Sea Wind To Calculate Current And Voltage In Small Scale Pltb
9	449	SEE	Alexandra Hukom	Incremental Capital Output Ratio (Icor) Analysis and Technology On Economic Growth In Kalimantan
10	454	SEE	Aisyah Trees Sandy, Mei Vita Romadon Ningrum, Edwardus Iwantri Goma	The Urgency of Tropical Studies Based Social Entrepreneurship in the Covid 19 Period
11	455	SEE	Andi Baladewa Armada Candra	Control of 3 Phase Induction Motor With Variable Speed Drive Based On PLC and SCADA
12	462	SEE	M. Fathurahman, Ika Purnamasari, Surya Prangga	Association Analysis of the Number of Dengue Hemorrhagic Fever Cases in East Kalimantan with the Factors of Geographic, Demographic, and Health Using Spearman Rank Correlation
13	469	SEE	Mursidah	Added Value Analysis of Eleutherine americana M. Herbal Tea



the 5<sup>th</sup> **ICTROPS**

International Conference  
for Tropical Studies and Its Applications

Islamic Development Bank 4in1 Project  
Project Implementation Unit  
University of Mulawarman



ISDB  
البنك الإسلامي للتنمية  
Islamic Development Bank



14	474	SEE	Marwan Marwan, Siti Khotimah, Ronny Isnwardana, Swandari Paramita	Development the Database of Antibody Level of COVID-19 Survivor for Convalescent Plasma Donors at Mulawarman University
15	481	SEE	Mahdi Ilhami, Ristiana Eriyati, Dewi Embong Bulan	The abundance of marine Sponges in the Miang Besar Island, East Kutai
16	479	SEE	Darnah Darnah	The Effectiveness of Online Learning Platforms on Mathematics Scores of Junior High School Students in Samarinda in COVID-19 Era
17	487	SEE	Imam Wijayadi	Economic Empowerment Of The Kampung Muang Ilir Community Through “Miltovil” (Muang Ilir Ecotourism Village)
18	491	SEE	Dina Lusiana Setyowat, Swandari Paramita, Riza Hayati Ifroh, Tanti Asrianti, Evi Fitriany, Wahnadita Rahman	Work readiness during COVID-19 among taxibike online drivers in Samarinda, Indonesia
19	492	SEE	Elsje Theodora Maasawet, Evie Palenewen , Herlan Perdana Putra	Influence of Virtual Laboratory Media Project Based Learning Model Based Independent Learning to Supports Critical Thinking, Creativity, and Communication Students
20	431	TCBD	Zeni Haryanto, Nurul Fitriyah Sulaeman, Atin Nuryadin, Shafira Aulia Putri, Annisa Zahra Rahmawati, Pramudya DA Putra	Microteaching for Pre-service Science Teachers during the COVID-19 Pandemic: A Theoretical Framework
21	475	TCBD	Saraswati Prabawardani, Lazarus Indow, Rudi A. Maturbongs, Hendri Hendri	The Influence of the Remote Indigenous Communities Empowerment Program on the Sustainability of the Local Food Crops at the Three Domberai Cultural Ecosystem Areas, West Papua
22	483	TCBD	Risa Farrid Christiani, Azhari S.N. Azhari	Computational Intelligent Algorithms in Multi-Sensor Data Fusion for UAV Detection and Identification: Challenges and Opportunities
23	414	TEE	Nina Yulianti	Sustainable Farming Lowland and Highland– A Case Study in Central Kalimantan, Indonesia dan Sabah, Malaysia
24	416	TEE	Blego Sedionoto Sedionoto, Sueptrakool Wasessombat, Chuchard - Punsawad, Witthaya - Anamnart, Jitbanjong - Tangpong	Geographical Risk Factors of Strongyloides stercoralis infection in East Kalimantan Province, Indonesia
25	417	TEE	Kiswanto Kiswanto, Ariyanto Ariyanto, Diah Rakhmah Sari, Mardiany Mardiany	Changes Detection of The Surface Coal Mining in Samarinda Using Time Series Landsat Imageries
26	421	TEE	Suria Darma Idris, Syamad Ramayana, Sadaruddin Sadaruddin, Bambang Suprianto	Comparison of Content and Status of the C-Organic, C/N Ratio, Soil pH and Organic Matter in Rainfed Rice Fields, Tides and Swamp (Case Study in Three Villages, in East Kalimantan)



the 5<sup>th</sup> **ICTROPS**

International Conference  
for Tropical Studies and Its Applications

Islamic Development Bank 4in1 Project  
Project Implementation Unit  
University of Mulawarman



IsDB  
البنك الإسلامي للتنمية  
Islamic Development Bank



27	423	TEE	Blego - Sedionoto, Vivi Filia Elvira	Essential Ecological Risk Factors of Strongyloides stercoralis infection in Rural Areas Kutai Kertanegara, Indonesia
28	433	TEE	Rusfina Widayati	The Use of AHP within GIS on Decision Making of Watershed Development Planning Policy at Bontang River–East Borneo
29	441	TEE	sifriyani sifriyani, Idris Mandang, Fidia Deny Tisna Amijaya	GIS Mapping Based on Spatial-Temporal Model Estimation Affecting COVID-19 Outbreak in Kalimantan
30	444	TEE	Nurul Novalia Kartika	Effect of UVA, UVC, UVA/TiO <sub>2</sub> , and UVC/TiO <sub>2</sub> for Degrading Synthetic Dyes
31	446	TEE	Risa Farrid Christianti, Azhari S.N. Azhari Mail	Computational Intelligent Algorithms in Multi-Sensor Data Fusion for UAV Detection and Identification: Challenges and Opportunities
32	450	TEE	Joan Angelina Widians, Annisa Chitra Adinda, Anindita Septiarini Septiarini Mail	Diagnose Digestive Disease and the Selection of Borneo Medicinal Plants as an Alternative Treatment
33	451	TEE	Indah Trisnawati, Mukhammad Muryono, Iska Desmawati Mail	Pollinator-friendly plants for supporting pollinator insect conservation on agroforestry in Jatiarjo, Prigen, East Java
34	453	TEE	Devita Grecia Naftalia Simorangkir	Photocatalyst Effect of Variations in TiO <sub>2</sub> /UVC Concentration to Degrade Variations in Concentrations of Synthetic Compounds (Methylene Blue) and Interfering Substances
35	456	TEE	Nurul Puspita Palupi, agus sarjono, abdul hanif	Soil Quality Index Analysis Of Secondary Forest And Palm Oil Plantation
36	458	TEE	Ade Kurniawan	Design of a Waste Power Plant Prototype Based on the Waste Types as a Source of Renewable Energy
37	459	TEE	Encik Akhmad Syaifudin	Eresponse of Shallots ( <i>Allium ascalonicum</i> L.) and Its Diseases On The Trichokompos Fertilizer And Frequency Of Weed Control
38	464	TEE	Kadis Mujiono	Insecticidal activity of Kirinyuh leaf extract ( <i>Chromolaena odorata</i> L.) against armyworm <i>Spodoptera litura</i> F. (Lepidoptera: Noctuidae)
39	465	TEE	Hadi Pranoto Pranoto	The intercropping pattern of corn ( <i>zea mays</i> l.) And peanuts ( <i>arachishypogaea</i> l.) on cavendes banana ( <i>musa acuminatocavendis</i> ) plantation to land productivity increases1)
40	466	TEE	Mohammad Sumiran Paputungan, Alan F. Koropitan, Tri Prartono, Ali A. Lubis, Isdahartati Isdahartati, Andi Afandy	Quantifying Carbon Stock In Mangrove Restoration Area Of Lembar Bay, Lombok
41	467	TEE	Joan Angelina Widians, Azhari Azhari SN	Text Document Clustering with Evolutionary Computational: A Review
42	468	TEE	Sopialena	Association Of Endophytic Fungi In Rice Root ( <i>Oryza sativa</i> L)
43	027	TEE	Rahmat Bakhtiar, Yadi, Natanael Tandirogang	Analysis of Covid 19 Variants in Samarinda City



the 5<sup>th</sup> ICTROPS

International Conference  
for Tropical Studies and Its Applications

Islamic Development Bank 4in1 Project  
Project Implementation Unit  
University of Mulawarman



IsDB  
البنك الإسلامي للتنمية  
Islamic Development Bank



44	028	TEE	Farida Djumiati Sitania	Supplier selection using AHP and TOPSIS : a case study in the X bakery
45	484	TEE	Teguh - Pribadi	Fauna Exploration and Inventory in the Mount Kelua Fkip Campus Area, Mulawarman University
46	422	TNP	Sara Ahmed Eltigani	Hemagglutinins Inhibitors from Tropical Medicinal Plants Used in Sudan
47	424	TNP	Usman	Antidiabetic and Antimicrobial Activities of the Ethanolic Extract from Rhizophora mucronata Leaf
48	429	TNP	Panggulu Ahmad Ramadhani Utoro, Miftakur Rohmah, Nur Amaliah, Anton Rahmadi, Rusdiansyah Rusdiansyah	Crystal Structure, Mineral Content, $\beta$ -Carotene, $\alpha$ -Tocopherol, Antioxidant and Functional Group Active of Pre-gelatinization and Pre-Digest White and Red Rice Flour from East Kalimantan as Source of Anti-Stunting Nutrients
49	435	TNP	Noor Hindryawati	Green Synthesis of Silver Nanoparticles From Soursop Leaf Extract ( <i>Annona Muricata</i> Linn.)
50	439	TNP	Gabriel Sumampouw	Prototype of Automatic System DC Fan Speed Based by Microcontroller, and Connected to Blynk (IOT)
51	442	TNP	Nabila Nayif Nur Akmalia	Potential of Nutraceutical Gummy Candy from Kepok Banana Peel Extract ( <i>Musa paradisiaca</i> Linn.) in Combination with Kelulut Honey ( <i>Trigona incisa</i> ) As a Covid-19 Supportive Therapy
52	445	TNP	Nova Hariani, Syafrizal Syafrizal, Andi Mismawati, Ritbey Ruga	Phytochemical analysis of ethanol extract from stingless bee ( <i>Tetragonula laeviceps</i> Smith) honey and its anti-acnes activity
53	452	TNP	Wisnu Candra Margono	Smart Trash Can Prototype Can Talk Accompanied by Security System Using Ultrasonic Sensors and PIR Sensors With Telegram Communication
54	457	TNP	Odit Ferry Kurniadinata, Penny Pujowati, Khoiru Indana, Donny Dhonanto, Agung Nugroho	Purun Plant in East Kalimantan, The Endemic Plants in Peat and Swamp Areas as A Humid Tropical Local Commodity with Superior Potential
55	471	TNP	Eva Marlina, Soerja Koesnarpadi, Nanang Tri Widodo, Sahira Fara Nabila, Novia Rahmawati Isyahro	Study Of Antioxidant Effectiveness Of Meniran Leaf Hybrid ( <i>Phyllanthus niruri</i> L.) with TiO <sub>2</sub> -Chitosan
56	477	TNP	Hetty Manurung, Eko Kusumawati	Screening of Phytochemical and GC-MS Analysis of Lai ( <i>Durio kutenjensis</i> Hass. Beck) The Endemic Plant In Kalimantan, Indonesia
57	480	TNP	Ritbey Ruga, Eva Marlina, Rita Hairani dan Winni Astuti	Anti acne activity of methanol extract from <i>Kaempferia galanga</i> L.
58	478	TNP	Nur Rani Alham, Ira Riyana Sari Siregar, Wisnu Candra Margono, Bayu Dwi Prabowo, Ulwan Fauzan Azhari	Utilization of Goat Manure Towards PLTB (Biogas) Prototypes in Simple Way

## Biological Waste and Wastewater Treatment Technology in Tropical Countries

**Eli Hendrik Sanjaya\***

Department of Chemistry, State University of Malang, Indonesia

*Corresponding Author\*: eli.hendrik.fmipa@um.ac.id*

### Abstract

Waste and wastewater is one of the big issues in this world. Every country has been working to solve this problem. Chemical, physical, thermal and biological processes have been proposed for the treatment of waste and wastewater. Among them, utilizing microorganism, biological method is environmental friendly and low operating cost. The optimal operation condition of the biological process is usually at mesophilic condition. It is very beneficial to be applied in tropical countries such as Indonesia with the temperature ranges from 20 to 30°C. Based on the oxygen demand, biological processes are divided into aerobic and anaerobic. Each process has its own advantages and disadvantages. The aerobic treatment is applied for treating low strength wastewater with COD of less than 1 mg/L, while the anaerobic process can commonly treat higher organic loading. In case of fish processing wastewater (FPW), a Self-Agitated Anaerobic Baffled Reactor (SA-ABR) succeed to treat the high concentration with the high organic loading rate. Moreover, the Calcium supplementation not only enhanced the reactor performance, but it also increased the resilience of anaerobic digestion to the ammonia inhibition.

**Keywords:** waste and wastewater, biological process, anaerobic digestion, fish processing wastewater.

### Introduction

The tropics are an area located between the isotherm lines in the northern and southern hemispheres, or areas located at 23.5° north latitude and 23.5° south latitude (Ilmu Geografi, 2016). The tropics can also be defined as a subsolar point, which is the area on the earth's surface that the sun passes directly overhead at least once during the solar year (Wikipedia, 2021). Basically, the tropical area can be divided into dry tropical areas which include steppes, dry savannas, and deserts and humid tropical areas which include tropical rain forests, areas with wet seasons and humid savannas.

Tropical region has so many benefits on natural resources and the climate, more than two thirds of the world's biodiversity are in the tropical regions. Tropical climate is so convenience for living things as it has warm temperature (Hartshorn, 2013). The temperature range of tropical region is 20 to 30°C. Sometimes in many places, the temperature rises to 36°C or more such as Surabaya City (Weather Spark, 2021), which is a mesophilic condition as the optimum temperature for many microorganism. Therefore, the organic matters will be decay easily when they are not sterile. It becomes a serious problem on air pollution, water bodies and depletes the ozone layer which increasing the climate change impact when the organic waste is not handled properly (Ayilara et al., 2020).

In many developing countries, such as Indonesia, the municipal solid waste (MSW) just for landfilling. During in landfilling, the organic matter produces methane (CH<sub>4</sub>), carbon dioxide (CO<sub>2</sub>) and others (Lee et al., 2017). Beside CO<sub>2</sub>, methane is actually a dangerous greenhouse gas (GHG) which push up the climate change. Methane makes up a tiny fraction of the atmosphere. The methane gas is approximately 80 times more effective than CO<sub>2</sub> in trapping heat in the Earth's atmosphere within 20 years after it is released. The methane concentration at atmosphere is expanding quicker presently than at any time since the 1980s (Environmental Defense Fund, 2021).

## Results and Discussion

### Waste and Wastewater Treatment

There are four methods in the treatment of waste and wastewater include physical, chemical, thermal, and biological process. However, most of wastewater treatment plan use the combination of those processes. Physical method consists of screening, pulverization (for reducing solids), flow equalization, mixing, flocculation, sedimentation, flotation, and screening/filtration. Chemical method includes precipitation, neutralization, ion exchange, oxidation and reduction. Thermal method utilizes high-temperature such as incineration. The incineration can detoxify the particular organic matters and destroy them. The last method is biological process, it uses microorganisms for treating the waste and wastewater.

Biological treatment consists of aerobic and anaerobic. Aerobic process requires oxygen and microorganisms to degrade organic matter and other pollutants such as phosphorus and nitrogen into water, carbon dioxide, and other biomass. Aerobic process is usually applied to treat low strength wastewater (COD < 1 g/L) when the treatment requires the presence of oxygen. On the other hand, the anaerobic process digests the organic waste in the absence of oxygen and resulting in biomass with the main product of carbon dioxide and methane. Anaerobic treatment is commonly applied in the treatment of wastewater with higher organic loading (COD > 4 g/L). Moreover, in anaerobic digestion, the flows of methane and carbon dioxide are very stable. The aerobic process and anaerobic process has its own benefit and drawback as shown in Table 1. However anaerobic is more favorable when the process is maintained properly, even it has no negative effect on human health or the environment (Anukam et al., 2019). The strengths and weaknesses of the aerobic and anaerobic digestion are provided in Table 2.

**Table 1.** The strengths and weaknesses of the aerobic and anaerobic digestion process

Parameter	Aerobic Treatment	Anaerobic Treatment
Substrate	Low to medium strength wastewater (COD < 1 g/L)	Medium to high strength wastewater (COD > 4 g/L)
Operating cost	Relatively high	Relatively low with payback since it generates energy
Energy consumption	Relatively high	Relatively low
Foot-print	Relatively large	Relatively small and compact
Sludge production	Relatively high	Relatively low
Post-treatment	basically direct discharge	Usually it needs the post treatment to fulfill wastewater standard discharge

### Anaerobic digestion case study: Fish Processing Wastewater (FPW)

The aerobic and anaerobic biological treatment have been applied to treat FPW in laboratory scale. Several researchers succeeded in treating FPW using an aerobic treatment. For instance, the aerobic biological treatment with activated sludge showed a very good result in treating fish canning industrial wastewater with highest total organic carbon (TOC) removal efficiency of 96% (Cristóvão et al., 2012) and high organic matter degradation rates in the average of 4900 mg-O<sub>2</sub>/g-COD/d (Cristóvão et al., 2016). On the other hand, even though not so many papers, anaerobic FPW treatment was also studied.

Several reactors were applied in lab scales, as shown in Table 3. Moreover, the combination of the anaerobic and aerobic process suggested being an optimal process of FPW treatment (Chowdhury et al., 2010). Other FPW treatment methods also proposed, for instance, Riaño et al. (2011) achieved

about 70% of TCOD removal efficiency, which showed that FPW could be effectively treated by using microalgae. Table 3 shows that the Self-Agitated Anaerobic Baffled Reactor (SA-ABR) succeed to treat high COD concentration of FPW in the range of 30-46 g-COD/L, while other reactor could only treat 4-6 g-COD/L for Upflow anaerobic sludge blanket reactor (UASB) reactor and 11.5 g-TOC/L for Continuous stirred tank reactor (CSTR). Moreover, the SA-ABR reached the high organic loading rate (OLR) of 6.77 g-COD/L/d without Calcium supplementation and increased to 7.62 g-COD/L/d when the Calcium was added to the substrate (Sanjaya et al., 2020, 2021). In addition, the calcium supplementation increased the resilience of the microorganisms to the ammonia inhibition.

**Table 2.** Advantages and disadvantages of anaerobic digestion process

Advantages	Disadvantages	Reference
Decreasing the greenhouse gas emissions.	Long recovery time when shock loading happens.	(Abdelgadir et al., 2014).
High COD removal efficiency for biodegradable matter.	Low pathogen and nutrient removal.	
Produce renewable energy (methane gas).	Takes a long start up.	
A high degree of waste stabilization is possible.	Generate bad odors.	
Simplicity.	Methanogenic bacteria has high sensitivity to many chemical compounds.	
Flexible in the reactor type and scale application (from very small to large scale).		
Low space requirement.		
Low oxygen and energy requirement		
The residual sludge and the effluent has prospective to be used as fertilizer and soil conditioner.		
Less chemicals and nutrients requirement.		
promising alternative to climate change reduction.	If the AD systems is maintained properly, it has no negative effect on the environment and human helath.	(Anukam et al., 2019)
does not require tedious and expensive maintenance steps		
adaptable to the climate conditions		
Produce methane as energy which has a potency to replace fossil fuels		

**Table 3.** Anaerobic treatment FPW

Reactor type	Substrate	Substrate concentration	Optimum OLR	COD removal efficiency (%)	Reference
Upflow anaerobic sludge blanket reactor (UASB)	Artificially mixed sardine and tuna canning	3-4 g-COD/L; 5% lipid	5–8 g-COD/L/d	78	(Palenzuela-Rollon et al., 2002)
Continuous stirred tank reactor (CSTR)	Fish processing wastewater	11.5 g-TOC/L	0.9 g-TOC/L/d	98.8	(Jemli et al., 2015)
Anaerobic fixed film	Tuna processing industry	N/A	2 g-COD/L/d	75	(Chowdhury et al., 2010)
SA-ABR	Fish processing wastewater	30-46 g-COD/L	6.77 g-COD/L/d	64	(Sanjaya et al., 2020)
SA-ABR With calcium supplementation	Fish processing wastewater	32.81 ± 3.20 g-COD/L	7.62 g-COD/L/d	89	(Sanjaya et al., 2021)

### Conclusions

Biological process of waste and wastewater treatment have highly potential to be applied in tropical countries since they have convenience temperature for microbial growth. As a biological process, anaerobic digestion has several benefit more than aerobic process, such as low operation cost and low sludge production. In case of the FPW, AD is a high potential method for treating it. The SA-ABR with the calcium supplementation achieved high performance in the treatment of FPW. Moreover, the calcium addition enhanced the resistant of microorganisms to the ammonia inhibition.

### REFERENCES

- Abdelgadir, A., Chen, X., Liu, J., Xie, X., Zhang, J., Zhang, K., Wang, H., & Liu, N. (2014). *Characteristics, Process Parameters, and Inner Components of Anaerobic Bioreactors* [Research article]. *BioMed Research International*. <https://doi.org/10.1155/2014/841573>
- Anukam, A., Mohammadi, A., Naqvi, M., & Granström, K. (2019). A Review of the Chemistry of Anaerobic Digestion: Methods of Accelerating and Optimizing Process Efficiency. *Processes*, 7(8), 504. <https://doi.org/10.3390/pr7080504>
- Ayilara, M. S., Olanrewaju, O. S., Babalola, O. O., & Odeyemi, O. (2020). Waste Management through Composting: Challenges and Potentials. *Sustainability*, 12(11), 4456. <https://doi.org/10.3390/su12114456>
- Chowdhury, P., Viraraghavan, T., & Srinivasan, A. (2010). Biological treatment processes for fish processing wastewater – A review. *Bioresource Technology*, 101(2), 439–449.





the 5<sup>th</sup> ICTROPS  
International Conference  
for Tropical Studies and Its Applications

Islamic Development Bank 4in1 Project  
Project Implementation Unit  
University of Mulawarman



ISDB  
البنك الإسلامي للتنمية  
Islamic Development Bank



<https://doi.org/10.1016/j.biortech.2009.08.065>

Cristóvão, R. O., Botelho, C. M. S., Martins, R. J. E., & Boaventura, R. A. R. (2012). Chemical and Biological Treatment of Fish Canning Wastewaters. *International Journal of Bioscience, Biochemistry and Bioinformatics*, 237–242. <https://doi.org/10.7763/IJBBB.2012.V2.108>

Cristóvão, R. O., Pinto, V. M. S., Martins, R. J. E., Loureiro, J. M., & Boaventura, R. A. R. (2016). Assessing the influence of oil and grease and salt content on fish canning wastewater biodegradation through respirometric tests. *Journal of Cleaner Production*, 127(Supplement C), 343–351. <https://doi.org/10.1016/j.jclepro.2016.04.057>

Environmental Defense Fund. (2021). *Methane: A crucial opportunity in the climate fight*. Environmental Defense Fund. <https://www.edf.org/climate/methane-crucial-opportunity-climate-fight>

Hartshorn, G. S. (2013). Tropical Forest Ecosystems. In S. A. Levin (Ed.), *Encyclopedia of Biodiversity (Second Edition)* (pp. 269–276). Academic Press. <https://doi.org/10.1016/B978-0-12-384719-5.00146-5>

Ilmu Geografi. (2016, June 11). Iklim Tropis: Pengertian, Ciri-ciri, dan Persebarannya. *IlmuGeografi.com*. <https://ilmugeografi.com/ilmu-bumi/iklim/pengertian-ciri-ciri-dan-daerah-sebaran-iklim-tropis>

Jemli, M., Karray, F., Feki, F., Loukil, S., Mhiri, N., Aloui, F., & Sayadi, S. (2015). Biological treatment of fish processing wastewater: A case study from Sfax City (Southeastern Tunisia). *Journal of Environmental Sciences*, 30(Supplement C), 102–112. <https://doi.org/10.1016/j.jes.2014.11.002>

Lee, U., Han, J., & Wang, M. (2017). Evaluation of landfill gas emissions from municipal solid waste landfills for the life-cycle analysis of waste-to-energy pathways. *Journal of Cleaner Production*, 166, 335–342. <https://doi.org/10.1016/j.jclepro.2017.08.016>

Palenzuela-Rollon, A., Zeeman, G., Lubberding, H. J., Lettinga, G., & Alaerts, G. J. (2002). Treatment of fish processing wastewater in a one- or two-step upflow anaerobic sludge blanket (UASB) reactor. *Water Science and Technology: A Journal of the International Association on Water Pollution Research*, 45(10), 207–212.

Riaño, B., Molinuevo, B., & García-González, M. C. (2011). Treatment of fish processing wastewater with microalgae-containing microbiota. *Bioresource Technology*, 102(23), 10829–10833. <https://doi.org/10.1016/j.biortech.2011.09.022>

Sanjaya, E. H., Cheng, H., & Li, Y.-Y. (2020). Mesophilic methane fermentation performance and ammonia inhibition of fish processing wastewater treatment using a self-agitated anaerobic baffled reactor. *Bioresource Technology*, 313, 123644. <https://doi.org/10.1016/j.biortech.2020.123644>

Sanjaya, E. H., Cheng, H., Qin, Y., Kubota, K., & Li, Y.-Y. (2021). The impact of calcium supplementation on methane fermentation and ammonia inhibition of fish processing wastewater. *Bioresource Technology*, 337, 125471. <https://doi.org/10.1016/j.biortech.2021.125471>

Weather Spark. (2021, October 10). *Iklim, Cuaca Menurut Bulan, Suhu Rata-Rata Surabaya (Indonesia)—Weather Spark*. <https://id.weatherspark.com/y/149170/Cuaca-Rata-rata-pada-bulan-at-Surabaya-Indonesia-Sepanjang-Tahun>

<https://en.wikipedia.org/w/index.php?title=Tropics&oldid=1044134605>

## SEE-411

# Analysis of the Impact of the Covid-19 Pandemic on the Coal Mining Industry Sector At Pt. Jhonlin Baratama Site Lolo, Js Group Paser Regency

Edwardus Iwantri Goma<sup>1\*</sup>, Mei Vita R Ningrum<sup>1</sup>, Adit Nur Pratama<sup>1</sup>, Risma Amelia<sup>1</sup>, Rita Wulandari<sup>1</sup>, Umi Kholifatus Saniah<sup>1</sup>, dan Yulia Sunarti<sup>1</sup>

<sup>1</sup>Geography Education, Faculty of Teacher Training and Education, Mulawarman University

Corresponding Author\*: [edgoma27@gmail.com](mailto:edgoma27@gmail.com)

### Abstract

The Covid-19 pandemic has had a major impact on every economic sector in Indonesia, including the mining industry sector. PT Jhonlin Baratama is one of the mining industries located in Kuaro District, Lolo Village, Paser Regency, directly adjacent to PT. Kideco Jaya Agung. The study aims to determine the impact of the Covid-19 pandemic on the mining industry sector. This research uses descriptive qualitative research. Data collection techniques were carried out using observation, interview and documentation techniques. The data analysis technique used in this research is to use the data analysis method of the Miles and Huberman model which is carried out in three stages, namely 1) data reduction; 2) Display data and; 3) Drawing conclusions. The results showed that the Covid-19 pandemic had an impact on the mining industry sector, namely, an intensive reduction in salaries, then a decrease in demand for existing coal and also the value of East Kalimantan's non-oil and gas exports during 2020 fell by 17.16%, where Kalimantan's non-oil exports East is dominated by mining products (coal). This proves that the pandemic has had a considerable impact on mining, especially coal mines.

**Keywords:** Covid-19, Mining Industry, Paser Regency

### Introduction

Indonesia is one of the countries that has the potential for energy and mineral resources that are quite large, including coal. There are 20 provinces that have coal resources, with South Sumatra and East Kalimantan being the provinces with the highest level of coal resources in Indonesia, which is equivalent to 82% of the total coal resources in Indonesia. Indonesia's coal resources reach 161.34 billion tons (MT) and reserves of 28.17 MT (Directorate General of Mineral and Coal, 2013). Coal production growth during 2008-2012 was 13% per year, with an average production of around 200 million tons per year. For domestic use of coal, the electricity sector is more dominant, the rest is for the cement, textile, fertilizer, metallurgical, and other industries. Coal production which always increases from year to year makes coal as the main commodity in the general mining sub-sector and occupies a very vital position and is one of the primary energy sources for the Indonesian industrial world (Directorate General of Mineral and Coal, 2013).

Coal is a natural resource that is not renewable or non-renewable resource, this means that once this mineral is exhausted, it will not be able to recover or return to its original state. Coal mining as mining in general is a series of activities that include the stages of general investigation, exploration, feasibility studies, construction, mining, processing and refining, transportation and sales and post-mining activities. The existence of the coal mining industry can have an impact on the environment, social and economy of the local community. In terms of its negative impact, mining is more often understood as an activity that causes more problems than benefits, ranging from disturbing health, conflicts over land grabs, environmental damage, to ex-mining areas that are left gaping. On the other hand, there are many benefits from mining activities, such as opening isolated areas, a source of regional original income, creating jobs so that it is a source of foreign exchange for the country

(Hakim, 2014).

Paser Regency is one of the coal contributor areas in East Kalimantan Province. The total area of Paser Regency is 11,603.94 Km<sup>2</sup>, covering land and sea areas. Among the sub-districts in Paser Regency, Long Kali District is the sub-district that has the largest area because it covers 20.56 percent of the total area of Paser Regency. Meanwhile, Tanah Grogot sub-district has the smallest area among the sub-districts in Paser Regency. Its area covers only 2.89 percent of the total area of Paser Regency. Mining sector including coal mining has a significant role in economic growth in Paser district. The value of GRDP from the mining and quarrying sector has increased significantly from year to year.

**Table 1.** GRDP Value by Current Prices 2009-2013 (in Millions of Rupiah)

Field of business	2009	2010	2011	2012	2013
Mining and excavation	7.181.386	10.086.581	12.917.131	13.691.208	

Source: Paser Regency BPS, 2014

The development of Covid-19 in Paser Regency is based on data from the Paser Health Office, according to the spokesman for the Covid-19 task force, Amir Faisol, who said, to this day, Paser Regency is still in the Red Zone. Covid-19 cases in Paser Regency reached 1754 positive cases of Covid-19 on January 31, 2021. Meanwhile, 1532 people recovered and some of them were still undergoing treatment. For the positive cases of Covid-19 as many as 54 people and 64 people who recovered. The data in each sub-district of Covid-19 cases in Paser Regency, including Tanah Grogot as many as 917 positive, 783 recovered and 23 people died. Batu Sopang District, positive 329 cases, recovered 298, died 6 people. Paser Belengkong District, 159 positive cases, 135 recovered, 2 people died. Kuaro District, positive 148 cases, recovered 131, died 4 people. Long Ikis Subdistrict, 89 positive cases, 82 recovered, and 3 people who died Long Kali Subdistrict, 47 positive cases, 42 recovered, 2 people died. Muara Komam sub-district, 25 positive cases, 24 recovered, none died. Batu Engau Subdistrict, 21 positive cases, 21 recovered and none who died, green zone. Muara Samu Subdistrict, 10 positive cases, 10 recovered, and none who died, green zone. Finally, Tanjung Harapan District, 9 positive cases, 8 recovered, none died.

Covid-19 is undeniably having an impact on the national economy. Various policies have been made by the Indonesian government to minimize the impact of Covid-19 on the Indonesian people. One of them is the policy of the President of the Republic of Indonesia, Joko Widodo, who issued Government Regulation in Lieu of Law (Perpu) Number 1 of 2020 concerning State Financial Policy and Financial System Stability for Handling the Corona Virus Pandemic. In Article 2 of the Perpu, it is possible for the government to relax the limitation of the budget deficit of more than 3 percent. Economic growth is projected to weaken significantly at 2.1 percent (most optimistic) to minus 3.5 percent in 2020 before returning to an average of 5.4 percent in 2021-2022 when aggregate demand has recovered (Plan et al., 2020). Think tanks and strategic thinkers corrected their projections, especially in 2020, which is likely to see a slowdown, recession, and even an economic depression. Development in every country is guaranteed to be disrupted. Each country revises its APBN and provides a large allocation of funds to overcome this corona outbreak. Technically, the types of community activities regulated in Minister of Health Regulation (PMK) No. 09 of 2020 concerning PSBB Guidelines as the Acceleration of Handling Covid-19 include closing schools and workplaces, restrictions on religious activities, restrictions on activities in public places, restrictions on social activities. culture, restrictions on transportation modes, and restrictions on other activities specifically related to aspects of defense and security. The government also emphasized the difference between PSBB and regional quarantine where people are not allowed to do activities outside their homes.

The increase in positive cases that occur from day to day causes a lot of losses to various sectors in Indonesia.

One of them is the Indonesian economic sector. The Covid-19 pandemic has severely damaged the Indonesian economy. The rupiah exchange rate is still not as weak as it is now. On March 2, 2020, the exchange rate of 1 USD against the rupiah was Rp. 14,265.00, as of today April 9, 2020 the exchange rate of 1 USD against the rupiah is Rp. 15,880.004 . So the rupiah weakened by 1.615 points or weakened by 11.32% in 39 days. The worst weakening of the rupiah until April 10, 2020, occurred on March 23, 2020, with the exchange rate of 1 USD against the rupiah of Rp. 16,575.00 or weakened by 16.19%.

Another economic impact is the movement of the Composite Stock Price Index (JCI) which is in free fall. JCI data shows that before there were Covid-19 cases in Indonesia, the JCI value was in the 6000's range, but after the Covid-19 outbreak in Indonesia, the JCI's value fell freely into the 4000's range. The enormous negative impact can already be seen from the industrial side in Indonesia. As of April 7, 2020, the Ministry of Manpower (Kemenaker) noted that more than 1.4 million workers throughout Indonesia were directly affected by the Covid-19 or corona outbreak (Sihaloho & Padjadjaran, 2020). The impact on the economic sector during the Covid-19 pandemic in Indonesia, among others:

The occurrence of massive layoffs There was a decline in Indonesia's Manufacturing PMI reaching 45.3% in March 2020. There was a 3.7% decline in imports in the first quarter. The occurrence of inflation which has reached 2.96% year-on year (yoy) which has been contributed from the price of gold and food commodities in March 2020. The occurrence of flight limitations resulting in a decrease in revenue in the sector. The perceived loss reached Rp. 207 billion. As many as 12,703 flights were canceled at 15 airports in January-March 2020. Six thousand hotels have decreased placement (occupancy) to reach 50%. This can result in a loss of tourism foreign exchange (Hanoatubun, 2020).

## Methodology

The research uses qualitative research methods. The purpose of qualitative research according to Bogdan and Taylor which has been quoted by Imam Gunawan is research that produces descriptive data in the form of written or spoken words from people, as well as behavior that can be observed in the individual background as a whole (Imam Gunawan, 2013) . Then for this research approach using descriptive-qualitative method. Where according to Suharsimi Arikunto that approach is a method used in conducting non-experimental research which, when viewed from the point of view of the goal, will obtain the type or types taken (Suharsimi Arikunto, 1993).

### Data collection technique

The data collection technique in qualitative research is by distributing questionnaires. Questionnaire is a data collection technique that is carried out by giving a set of questions or written statements to informants for answers (Sugiyono, 2018). Then in this study, researchers interviewed 2 informants consisting of workers from PT Jhonlin Baratama Site Lolo.

### Sampling technique

This study used a purposive sampling technique. Purposive sampling is a sampling technique of data sources that have been considered (Sugiyono, 2018). The consideration in this study is time, therefore researchers consider informants who can provide information according to the criteria and needs. The criteria for selecting research informants are workers who have smartphones and can operate smartphones smoothly. The workers who have been selected are workers who are in the age of 20 and 25 years, and are currently working at PT. Jhonlin Baratama Site Lolo with 7 months and 5 years of work.

## Data analysis technique

The data analysis technique used in this study is to use the data analysis method of the Miles and Huberman model which is carried out in three stages, namely 1) Data reduction, at this early stage selecting, focusing, simplifying, abstracting and transforming raw data in written notes. The aim is to obtain findings which then become the focus of the research; 2) Data display, in this stage the reduced data is then displayed to provide an understanding of the data in order to determine the next step; 3) Drawing conclusions, after data reduction and display are carried out, conclusions are made or conclusions are drawn from the data that has been studied (Milya Sari & Asmendri, 2020).

## Results and Discussion

### Research sites

PT Jhonlin Baratama is a subsidiary of the Jhonlin Group which was founded in 2003 and is headquartered in Tanah Bumbu Regency, South Kalimantan. The location of PT Jhonlin Baratama is in Kuaro District, Lolo Village, Paser Regency, directly adjacent to PT. Kideco Jaya Agung. PT. Jhonlin Baratama managed to achieve ISO 9001: 2008 certification which is a brilliant achievement for PT. Jhonlin Baratama.



Figure 1. Research Location  
(Source: Private Collection, 2021)

### The Impact of Covid-19 on the Mining Industry at PT. Jhonlin Baratama Site Lolo

Indonesia is one of the countries rich in minerals, which include gold, silver, copper, oil, natural gas and coal is one of them. We can know that the coal mining industry itself can increase the country's foreign exchange, if it is managed in accordance with applicable procedures and rules. The mining industry can indirectly have a positive impact on the local community through empowerment efforts, by providing jobs in certain sectors. With the mining industry, it can also help the community to fulfill their daily needs. As we know, currently all countries are experiencing difficult conditions, which affect all aspects of social, economic, political, as well as all activities of human life. In this case, both the government and the community feel the impact of the Covid-19 pandemic.

At this time a number of countries are still struggling to deal with Covid-19. This condition also has various impacts, especially on the industrial sector, one of the industries affected is the coal industry in the Kalimantan area. With the existence of a mining company in the midst of the community, it can improve and develop community development there. Between the company and the community around the mine, there are components that influence each other. Both need each other to be able to develop the company and improve the community's economy. In improving the economy, communities around the mine can open up business opportunities such as establishing basic food stalls, restaurants, or renting out houses for workers who migrate. Along with the development of the mining industry, it can change the pattern of people's lives, one of which is the shift in livelihoods by depending on mining companies due to land changes or damage to agricultural land.



the 5<sup>th</sup> ICTROPS  
International Conference  
for Tropical Studies and Its Applications

Islamic Development Bank 4in1 Project  
Project Implementation Unit  
University of Mulawarman



IsDB  
البنك الإسلامي للتنمية  
Islamic Development Bank



The Covid-19 pandemic is currently pressing the market and coal prices. This condition greatly impacted the national coal production decline by 11% in the early 11 months of 2020. Dodik (2020) said that there were three factors that caused the decline in production compared to the previous year. First, the demand for coal consumption has decreased due to the pandemic. Second, there was a rapid decline in coal prices, third, there was limited access or mobility of employees and logistics of mining companies during the pandemic. Then it was also said that the companies most affected were coal companies with coal quality below 4,000 kcal and did not have long-term contracts, as a result their production was reduced and had to stop.

Based on the results of the study, it is also known that most of the employees of PT. Jhonlin Baratama Site Lolo complained about the lack of manpower, due to the reduction in staff and the quarantine system implemented by the company. Then there was an intensive reduction in wages, then a decline in coal demand. This fact is reinforced by a report from the Central Statistics Agency (2021), namely the impact of Covid-19 on businesses in the mining and quarrying category, BPS reported that the value of East Kalimantan's non-oil exports during 2020 fell 17.16%, where East Kalimantan's non-oil exports were dominated by mining products. (coal). The same thing was also found in the results of research conducted by Hendra in 2020 where the supply of coal was still strong, but due to a decrease in demand resulting in oversupply occurring in the global market resulting in a downward trend in prices, this trend also made Indonesian coal experience negative growth due to selling coal at a price below the cost of production. Another impact is the number of companies trying to sell coal domestically because the price is much better than the export price. This proves that the pandemic has had a considerable impact on mining, especially coal mines.

## Conclusion

Indonesia is one of the countries that has the potential for energy and mineral resources that are quite large, including coal. There are 20 provinces that have coal resources, with South Sumatra and East Kalimantan being the provinces with the highest level of coal resources in Indonesia, which is equivalent to 82% of the total coal resources in Indonesia. The Covid-19 pandemic is currently pressing the market and coal prices. This condition greatly impacted the national coal production decline by 11% in the early 11 months of 2020. Then it was also said that the companies most affected were coal companies with coal quality below 4,000 kcal and did not have long-term contracts, as a result their production was reduced and had to stop. most of the employees of PT. Jhonlin Baratama Site Lolo complained about the lack of manpower, due to the reduction in staff and the quarantine system implemented by the company. Then there was an intensive reduction in wages, then a decline in coal demand. This fact is reinforced by a report from the Central Statistics Agency (2021), namely the impact of Covid-19 on businesses in the mining and quarrying category, BPS reported that the value of East Kalimantan's non-oil exports during 2020 fell 17.16%, where East Kalimantan's non-oil exports were dominated by mining products (coal).

## REFERENCES

- BPS. (2009). *Pertumbuhan Ekonomi Indonesia Tahun 2008*. 11, 1–8.
- BPS. (2015). *Indonesia Economic Growth 2014*. 17/02/Th.XVIII, 1–22.
- Dirjen Mineral dan Batubara. 2013. *Mineral and Coal 2013*. Direktorat Jenderal Mineral dan Batubara. Jakarta.
- Hakim I. 2014. *Dampak Kebijakan Pertambangan bagi Masyarakat Bengkuring Kelurahan Sempaja Selatan Kecamatan Samarinda Utara*. <http://ejournal.ip.fisip-unmul.ac.id> Diakses pada tanggal 30 Mei 2021.
- Mahrta, Mintarti, S., & Fitriadi. (2016). *Analisis Sektor Ekonomi Provinsi Kalimantan Timur*. *Jurnal Ekonomi Keuangan, Dan Manajemen*, 12(2), 235–249. <http://journal.feb.unmul.ac.id>



the 5<sup>th</sup> ICTROPS

International Conference  
for Tropical Studies and Its Applications

Islamic Development Bank 4in1 Project  
Project Implementation Unit  
University of Mulawarman



IsDB  
البنك الإسلامي للتنمية  
Islamic Development Bank



Milya Sari, A., & Asmendri. (2020). Penelitian Kepustakaan (Library Research) dalam Penelitian Pendidikan IPA. *NATURAL SCIENCE: Jurnal Penelitian Bidang IPA Dan Pendidikan IPA*, 6(1), 15. <https://ejournal.uinib.ac.id/jurnal/index.php/naturalscience/article/view/1555/1159>

Nayenggita, G. B., Raharjo, S. T., & Resnawaty, R. (2019). Praktik Corporate Social Responsibility (Csr) Di Indonesia. *Focus : Jurnal Pekerjaan Sosial*, 2(1), 61. <https://doi.org/10.24198/focus.v2i1.23119>

Pemerintah Daerah Kabupaten Paser. Teritorial Paser. <https://paserkab.go.id/home/teritorial>. Diakses pada tanggal 30 Mei 2021.

Perencanaan, K., Nasional, P., Republik, B., Abstraksi, I., Baru, N., Pembangunan, R., Menengah, J., Kunci, K., Journal, T. I., Planning, D., & Iv, V. (2020). Covid-19, New Normal, dan Perencanaan Pembangunan di Indonesia. *Jurnal Perencanaan Pembangunan: The Indonesian Journal of Development Planning*, 4(2), 240–252. <https://doi.org/10.36574/jpp.v4i2.118>

RAD GRK Kalimantan Timur 2010-2030 <https://bappeda.KalimantanTimurprov.go.id/storage/file/Yuv1h5m4gqYWUcx2.pdf>. Diakses pada tanggal 30 Mei 2021

Sinaga, R., Rochaida, H. E., & Ulfah, H. Y. (2013). Pengaruh Investasi PMDN, PMA, dan Tenaga Kerja terhadap Ekspor: Sektor Pertambangan dan Pertumbuhan Ekonomi di Kalimantan Timur. *Ekonomi Dan Bisnis*, 10(2), 312–328.



the 5<sup>th</sup> ICTROPS

International Conference  
for Tropical Studies and Its Applications

Islamic Development Bank 4in1 Project  
Project Implementation Unit  
University of Mulawarman



IsDB  
البنك الإسلامي للتنمية  
Islamic Development Bank



## SEE-412

# The Impact of Covid 19 on Street Vendors in the Scout Street Area of Samarinda City

Edwardus Iwantri Goma<sup>1\*</sup>, Mei Vita R Ningrum<sup>1</sup>, Muh. Ashar<sup>1</sup>, Nur Halizah<sup>1</sup>, Reni Novita<sup>1</sup>,  
Yudi Suherman<sup>1</sup>, Zaitun Alia A. Sanusi<sup>1</sup>

<sup>1</sup>Geography Education, Faculty of Teacher Training and Education, Mulawarman University

Corresponding Author\*: [edgoma27@gmail.com](mailto:edgoma27@gmail.com)

### Abstract

Corona virus (Covid-19) is a new virus that spread in 2020, this virus is a new type of virus (SARS-CoV-2) whose disease is called Coronavirus disease 2019 (COVID-19). The rapid spread of this virus has resulted in social and economic problems that have occurred in almost all parts of the world, including Indonesia. In Indonesia, almost all areas are affected by social and economic changes, such as on the Pramuka Samarinda road. This study aims to find out how the impact of Covid 19 on street vendors in the Scout Street area of Samarinda City. This study uses qualitative methods, while the data collection technique used is data collection by interviewing several sources who sell on Jalan Pramuka. The data analysis technique was descriptive statistical method which then the results of this interview were processed into data in the form of graphs and explanations. The results showed that the Covid-19 pandemic had an impact on decreasing the turnover and income of street vendors in the Scout Street area by 50%.

**Keywords:** Covid-19, Street Vendors, Samarinda

### Introduction

The development of Covid-19 cases in Indonesia has reached a stage where there is concern and unrest because Covid-19 cases in Indonesia have not continued to decline, even to the point that many areas in Indonesia are included in the red zone and make each regional government move quickly to make efforts or making policies to reduce the number of positive cases of Covid-19, which continues to increase, making residents worry and worry about Covid-19, which is not getting better. In Indonesia alone, as of Sunday (7/6/2020), the number of positive cases recorded was 31,186 patients, 10,498 patients were declared cured and 1,851 patients were declared dead. The accumulated data was taken from the results of specimen examination as many as 354,434 people carried out using the polymerase chain reaction (PCR) method in a total of 101 laboratories, molecular rapid tests (TCM) in 60 laboratories and network laboratories (RT-PCR and TCM) in 180 lab. In total 354,434 people have been tested and the results are 28,233 positive (cumulative) and 218,200 negative (cumulative), as stated by the spokesman for the Government for Covid-19, Achmad Yurianto, in an official statement at the Media Center office of the Task Force for the Acceleration of Handling Covid-19, Graha National Disaster Management Agency (BNPB) Jakarta, Sunday (7/6/2020).

Some areas that are included in the red zone have implemented large-scale social restriction policies such as the City of Samarinda. The extension of this large-scale social restriction period is carried out in order to accelerate the handling of Covid-19 in Samarinda City and the extension of this large-scale social restriction can still be carried out if there is evidence of the spread of Covid-19 and the development of positive cases that continues to increase in the city of Samarinda. Update on cases and coverage of Covid-19 vaccinations in Samarinda As of May 25, 2021. The addition of positive cases in Samarinda was 39 cases, 5 cases recovered, 0 cases died. The large-scale social restriction policy in Samarinda City is certainly intended to prevent and minimize the spread of the Covid-19 virus, but it turns out that not everything can go well with this policy, the





International Conference  
for Tropical Studies and Its Applications

Islamic Development Bank 4in1 Project  
Project Implementation Unit  
University of Mulawarman



IsDB  
البنك الإسلامي للتنمية  
Islamic Development Bank



side effect of the PSBB policy is that industry, business and livelihoods have stalled. One of them is Street Vendors (PKL) in the Scout Street area who also feel the side effects of the PSBB policy, where the income of street vendors has decreased due to the PSBB policy which regulates restrictions on the number of buyers, restrictions on selling time, restrictions on distance between buyers, no it is permissible to have a seat for buyers and so on. With a decrease in income, it will certainly cause problems that arise such as not being able to pay house rent or vehicle loan money, not being able to buy raw materials, not having capital to sell, reduced or no income to support daily life so that the worst part had to close the business (selling it) because of a drastic decrease in income.

The Central Government through the Ministry of Health issued Government Regulation (PP) No. 21 of 2020 concerning Large-Scale Social Restrictions in the context of accelerating the handling of Covid-19 which was signed on March 31, 2020. The Impact of Covid-19 on the Decline of Income of Street Vendors-During a pandemic such as In this case, it is not only teaching and learning activities that are hampered, but the community's economy is also hampered. The impact of the COVID-19 pandemic has greatly affected every aspect of life, such as street vendors. There are some who reap the loss, but many also feel the profit. The impact of the COVID-19 outbreak has affected many sectors of life, including the lower levels of society such as street vendors (PKL). These street vendors feel the loss due to the decline in buyers. The #StayHome movement has caused the economy of street vendors to decline.

Street trading activities are still carried out because street vendors are the places most needed by the community to get their daily basic needs. Traders who sell in the market must continue to apply health protocols such as wearing masks, washing hands, and maintaining distance to prevent the spread of COVID-19. Small traders need to be considered as targets for assistance by the government during this COVID-19 pandemic. The policies taken by the government must ensure that the middle and lower classes of society are able to fulfill their needs to ensure the right to life of their people and that the dignity of the community is not reduced by anything.

The most visible economic externalities of the COVID-19 pandemic are the phenomenon of the proliferation of laid-off employees, layoffs (PHK), and various companies that went bankrupt or went out of business (Burhanuddin and Abdi, 2020). Based on data from the Ministry of Manpower (Kemnaker) in 2020, the total number of workers who have been laid off and laid off during this pandemic has reached 1,943,916 people from 114,340 companies (Work Team of the Ministry of Home Affairs, 2020). This condition directly affects other sectors, especially from the casual daily worker sector, driving SMEs, restaurant or restaurant businesses, and businesses originating from the community that depend on the presence of crowds or crowds. Since the Covid-19 pandemic spread to Indonesia, 5.2 million people became new unemployed with the accumulation of workers who were directly affected by layoffs and small and medium business actors who had to go bankrupt or go out of business (Kirana, 2020). This condition automatically affects the purchasing power of the people, which drastically decreases, where the circulation of money in the community becomes very minimal, at the same time goods production activities are very limited, resulting in a trade deficit in the economic cycle (Kurniawansyah et al, 2020) . Regarding the poverty rate, there are factors that determine the occurrence of this, including the average monthly income, education level, family size, and disease incidence which are used as determinants of the significance of poverty (Asubalew, 2006).

## Methodology

This study used qualitative research methods. The purpose of this study was to determine the impact of Covid-19 on street vendors at Jl Pramuka. Data collection techniques used by interviewing several sources who sell on Jalan Pramuka. The data analysis technique used in this research is to use the Miles and Huberman model data analysis method which is carried out in three stages, namely 1) Data reduction, at this early stage selecting, focusing, simplifying, abstracting and transforming the raw data. in written records. The aim is to obtain

findings which then become the focus of research; 2) Data display, at this stage the reduced data is then displayed to provide an understanding of the data in order to determine the next step; 3) Drawing conclusions, after reducing and displaying data, conclusions are made or conclusions are drawn from the data that has been studied (Milya Sari & Asmendri, 2020).

## Results and Discussion

The Covid-19 pandemic has led to a loss of shoppers, as they have to stay home and tighten spending due to declining incomes. There are MSMEs and small traders who can still operate and some choose to close in an undetermined time. The survival ability of SMEs and small traders is less than 1 month. Meanwhile, they are required to continue to produce something to cover household needs and some basic business operational needs such as rent, credit, and employee salaries.

The impact felt by street vendors in the Pramuka Street area of Samarinda City is that buyers are quiet, based on the results of interviews with street vendors on Pramuka Street, it was found that the Covid-19 pandemic has made traders deserted with buyers so that some sellers who choose not to sell are added. This is because the average buyer in the Scout Street area is students studying at Mulawarman University. During the COVID-19 pandemic, students were put on holiday by the campus and took online lectures, and most students chose to return to their respective villages and take online lectures from their respective homes. This fact has an impact on decreasing the income of street vendors in the Scout road area. The decrease in visitors resulted in the income of traders experiencing a decrease of up to 50% when selling during the pandemic. "At a time of a pandemic like this, merchandise is not selling well, which usually gets 500 thousand a day, now 200 thousand is difficult," said one of Nasi Campur trader. The government's large-scale restriction policy that sometimes makes them unable to carry out their usual trading activities has resulted in no income to meet their daily needs. Traders also have to use their savings/savings to meet the necessities of life during the pandemic which cannot be covered only from current income.

Street vendor 1 (32 years old) Nasi Campur seller who sells on Jalan Pramuka Samarinda earns income when selling before the Corona pandemic, which is Rp. 500,000, - while when selling during the Covid-19 pandemic the income decreased to Rp. 200,000,-. The impact of Covid-19 has made street vendors' merchandise quiet, so the strategy in dealing with this impact is to be more efficient for daily needs. Other respondents also complained about the decline in their income as traders. Several strategies were implemented, such as street vendors 5 (35 years old) having to reduce the supply of broiler chickens. street vendors 5 strategy to reduce losses is to sell food a little cheaply. The strategy applied to sell merchandise online is as done by Suwarno, a snack seller on Jalan Pramuka. The lower-middle class community is most at risk of being affected by the Covid-19 outbreak. Some of them are now living without work, without income. Others stumbled to maintain their business. If nothing changes in the near future, they may fall into the abyss of poverty. Such is the picture of the life of a street vendor 3 (30 years) now. The fried rice vendor for the cart started to complain about the lack of sales. Its turnover has fallen drastically by around 50 percent since Covid19 hit. "Now it's getting worse since the large-scale social restrictions (large-scale social restrictions) in Samarinda,". However, Suwarno had no other choice. He had to keep selling to support his family. Although there is no guarantee that his wares will sell, he at least tries. He had to fight the fear of being exposed to Covid-19.

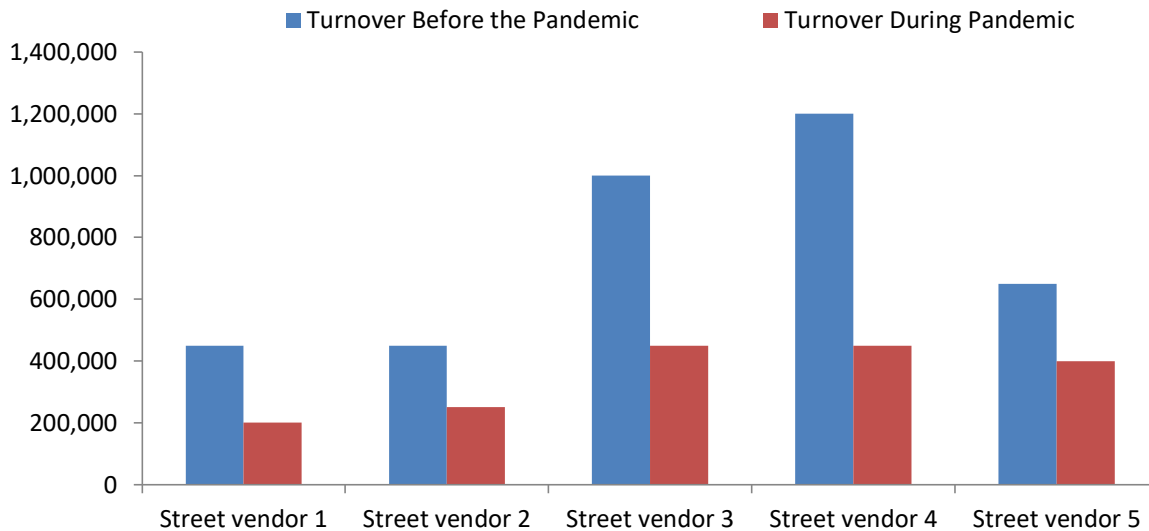

**Figure 1** Income Diagram of street vendors on scout streets during the pandemic and before the pandemic

### Conclusion

Covid-19 is an infectious disease caused by a coronavirus. Based on the results and discussion presented above, it can be concluded that the impact of street vendors, especially in the Pramuka street area of Samarinda city due to the covid-19 outbreak, one of which is that traders become quiet, lack of buyers because there are some sellers who choose not to sell plus again the number of buyers has decreased drastically since the covid-19 virus emerged. Traders continue to sell to meet their daily needs while still complying with health protocols, namely wearing masks when selling. The decrease in visitors resulted in the income of traders experiencing a decrease of up to 50% when selling during the pandemic. Thus, COVID-19 has had a negative impact on the economy of the people in Indonesia.

### REFERENCES

- Abdusshomad, A. (2020). Pengaruh Covid-19 terhadap Penerapan Pendidikan Karakter dan Pendidikan Islam. QALAMUNA: Jurnal Pendidikan, Sosial, dan Agama, 12(2), 107-115.
- Burhanuddin, C.I., Abdi, M.N. 2020. “Ancaman Krisis Ekonomi Global dari Dampak Penyebaran Virus Corona (Covid-19)”. Jurnal AkMen STIE Nobel Indonesia. Vol. 17 No. 1 Maret 2020. 90-98.
- Hanoatubun, S. (2020). Dampak Covid-19 terhadap Prekonomian Indonesia. EduPsyCouns: Journal of Education, Psychology and Counseling, 2(1), 146-153.
- <http://www.covid19.kaltimprov.go.id/>
- <http://www.dinkes.kaltimprov.go.id/>
- <https://kumparan.com/nfirdausi13/dampak-pandemi-covid-19-terhadap-pedagang-di-pasar-tradisional-1v11HqhuajI>
- <https://kumparan.com/silvia-novri-zulmi/dampak-covid-19-terhadap-penurunan-pendapatan-pedagang-kaki-lima-1um3zisi76M>



the 5<sup>th</sup> ICTROPS

International Conference  
for Tropical Studies and Its Applications

Islamic Development Bank 4in1 Project  
Project Implementation Unit  
University of Mulawarman



IsDB  
البنك الإسلامي للتنمية  
Islamic Development Bank



<https://news.unimal.ac.id/index/single/1355/pukulan-covid-19-terhadap-pedagang-kecil>

Kirana, J., Rajagukguk, K.P., Lubis, E.L.S. 2020. “Analisis Dampak Covid-19 Pada Masyarakat Sumatera Utara”. *Jurnal Ilmiah Mahasiswa Prodi PGSD*. Vol.1 No. 1 Juni 2020. 64-69.

Kurniawansyah, H., Amrullah, M., Salahuddin, Muslim, Sri Nurhidayati. 2020. “Konsep Kebijakan Strategis dalam Menangani Eksternalitas Ekonomi Dari Covid-19 Pada Masyarakat Rentan di Indonesia”. *Indonesian Journal of Social Sciences and Humanities*, Vol. 1 No. 2. 130- 139.

Milya Sari, A., & Asmendri. (2020). Penelitian Kepustakaan (Library Research) dalam Penelitian Pendidikan IPA. *NATURAL SCIENCE: Jurnal Penelitian Bidang IPA Dan Pendidikan IPA*, 6(1), 15. <https://ejournal.uinib.ac.id/jurnal/index.php/naturalscience/article/view/1555/1159>

Yunus, Rohim, N., & Rezki, A. (2020). Kebijakan Pemberlakuan Lock Down Sebagai Antisipasi Penyebaran Corona Virus Covid-19. 7(3).

## SEE-418

# Teacher Self-Efficacy for Professional Development during the COVID-19 Pandemic in East Kalimantan

Suryaningsi Suryaningsi<sup>1\*</sup>, Nurlaili Nurlaili<sup>2</sup>, Meiliyani Siringoringo<sup>3</sup>

<sup>1,2</sup>Faculty of Teacher Training and Education Mulawarman University Samarinda 75123, Indonesia

<sup>3</sup> Statistics Study Program Faculty of Mathematics and Science Natural Knowledge Mulawarman University, Indonesia

<sup>1</sup>Corresponding author\*: [Suryaningsi@fkip.unmul.ac.id](mailto:Suryaningsi@fkip.unmul.ac.id)

### Abstract

Teacher affects the professional competence of teachers during the COVID-19 pandemic. Teachers are still required to be able to construct the knowledge, skills, and attitudes of students in online learning. This study aims to investigate the self-efficacy experience of junior high school teachers to remain professional during the COVID-19 Pandemic. The research method uses a qualitative type with a narrative approach which is carried out from August to September 2021. Data collection first conducts observations by taking initial data at the education office as many as 35 teachers but only 14 teachers are willing to be interviewed as respondents in primary data using a purposive approach. sampling. Then identify and then conduct online interviews, the data obtained are then grouped according to the needs of research data and given coding and then reduced, displaying data and drawing conclusions. The results showed that the experience of self-efficacy of junior high school teachers to remain professional during the COVID-19 pandemic was difficult. Failures occur when constructing the knowledge, skills, and attitudes of students, so some teachers decide to attend workshops to help online learning. Teachers, students, and parents are worried because they cannot do their best due to the very limited support for online learning facilities. Teachers are also challenged to master the technology so that online learning continues to be carried out with the support of workshop activities to increase competence and quality of learning. The conclusion that the self-efficacy experienced teachers to remain professional is still dubious and even causes stress, because teachers are increasingly busy and work hard to prepare and ensure that learning remains effective. The practical implication is that the results of future research can be tested by teachers in high school.

**Keywords:** COVID-19, professional competence, online learning, self-efficacy teacher.

### Introduction

The COVID-19 pandemic has hit the world in almost two years. Various changes occurred both in the aspects of the economy, health, social behavior, government, and education (Courtemanche et al., 2020). There is a policy set by the government to shift work that should be done in the office, schools have changed to be done at home. Limiting distance with the term social and physical distancing, granting restrictions on community activities. Finally, education immediately took the attitude to innovate, everything was done easily and quickly (Copeland et al., 2021). The application of service acceleration and various shifts provides space for accelerating the application of education in the industrial revolution 4.0 era. All school subjects are required to make changes quickly by adapting to utilizing technology.

Online learning has become a necessity during the COVID-19 Pandemic. It is a solution to keep learning amid a storm hitting all of humanity in this world. The use of technology in communication and learning can create opportunities and challenges in the implementation of education (Bento et al., 2020). A new opportunity that arises is the development of multimedia, a learning method that cannot be limited. Opening opportunities for

someone to continue to work and develop themselves in education (Frutos et al., 2020).

Mastery of technology and adaptation of teachers in learning systems such as the use of the Zoom application, Google meet, LMS, and others, as well as the use of laptops, Android, and various other types. Everything can be used so that the implementation of online learning becomes very important. Finally, teachers will experience challenges in online learning (Fessell & Cherniss, 2020).

The low *self-efficacy* of teachers in carrying out their duties to always develop themselves as professional teachers, so that efforts to achieve teacher professionalism are still lacking (Dahl, 2019; Perren et al., 2017). Bandura, (1982) states that the ability to do something, at a high level, depends on the belief that a person has in his abilities.

Teachers have not passed certification as a symbol of professionalism. It is important to make efforts to improve the quality of teacher education starting with increasing professionalism, because, in the learning process, teachers have very strategic functions and roles, especially in dynamizing teaching and learning activities (Yuanita et al., 2019). The demands and obligations of a teacher to be called a professional are the first that a teacher must fulfill is to achieve a minimum education level of bachelor degree (S1) or diploma four (D4) and or be 50 years old with a working period of at least 20 years, is to join a certification program to obtain an educator certificate.

Teachers' lack of attention to discipline is even found in teachers who are late for school and also go home early (Kunesh & Noltemeyer, 2015). Discipline-based on awareness will support successful learning (Zhao & Liu, 2021). Winberg et al., (2018) The implementation of learning is strongly supported by high discipline from the teacher. The realization of a safe, orderly, and orderly school makes students able to study in peace (Kartadinata et al., 2011). Schools need to have rules of conduct that contain orders and prohibitions as well as strict sanctions (Siegel, 2014). Thus, all components of the school must uphold the rules that apply in the school.

It was found that there were teachers who did not implement online learning based on a predetermined schedule, even the teacher only gave assignments. A teacher develops duties and roles as educating, teaching, and training (Sato et al., 2020). Besides that, the teacher can manage the class effectively and pleasantly and be able to read the situation and condition of the students in the class so that the learning process can be carried out professionally. The duties of this teacher have been legally stated in Government Regulation No. 74 of 2008 concerning Teachers. Article 1 states that teachers are professional educators with the main task of educating, teaching, guiding, directing, training, assessing, and evaluating students. The high level of commitment and professionalism of teachers in carrying out their main tasks in schools will potentially increase the quality of education.

The teacher's inability to master technology is due to limited infrastructure. Learning that utilizes ICT optimally will be able to improve student achievement (Gerick et al., 2017). Learning by utilizing or integrating ICT can make it easier for teachers and students because it provides opportunities for students to learn dynamically and interactively (Solar & Dockendorff, 2019). In addition, students can find learning materials easily if they use ICT (Retnawati et al., 2018). (Retnawati et al., 2018), The low ability of teachers to use ICT in learning is a challenge that must be solved to improve the quality of education.

Based on the results of the literature search above, there have not been many studies related to the *self-efficacy* of professional teachers in online learning during the COVID-19 pandemic. Previous research is more related to the professionalism of teachers in offline learning. No research aims to investigate the *self-efficacy* of teachers to continue to realize professional competence during the COVID-19 demonstrations. The purpose of the study is to investigate The Self-Efficacy of Teachers for Professional Development in the time of the

COVID-19 Pandemic. The purpose of the study is to investigate The Self-Efficacy of Teachers for Professional Development in the time of the COVID-19 Pandemic.

## Methodology

Qualitative research with a narrative approach, collecting data through observation, namely a follow-up to previous research, using interview instruments to collect data. Several sources of literature are used both from articles and regulations as well as the latest news info done by documenting. The research target was East Kalimantan teachers, collecting data on teachers through purposive sampling technique, namely 14 teachers who were willing to become respondents, with the following steps: First, visiting the East Kalimantan Provincial Education Office to identify schools and teachers who would be designated as respondents and participants; Second, each teacher gave a questionnaire in the form of a google form to fill in the willingness to become a respondent and a participant who would be interviewed as many as 6 teachers through an online system: Zoom or Video Call and the rest to fill out the questionnaire as an unlimited number of participants, the more it strengthened the interview data; Third, carried out without coercion; Fourth, for those who are willing to be followed up, Fifth, teachers who are willing to be respondents and participants will be given online training through workshops or webinars on becoming a professional teacher in the Covid-19 Pandemic Period. The final stage of data collection, distributing questionnaires to measure the level of ability, motivation of teachers to prepare themselves to become professionals. The research will be conducted in August-October 2021. Triangulation data is carried out for data collection that combines data from various data collection techniques and existing data sources. In this triangulation method, researchers collect data and at the same time test the credibility of the data, namely checking the credibility of the data with various data collection techniques and various data sources. Data analysis was done by collecting data and then predicting and then displaying it and then drawing conclusions according to (Miles & Huberman, 1994).

References *self-efficacy* is Teachervery important to support the realization of increasing teacher professionalism. As Bandura, (1982) states that with *self-efficacy* teachers the teachers believe in their ability to carry out aspects of planning, organizing, and active teacher action to realize educational goals. Besides, Bandura also stated that *self-efficacy* is namely strongly influenced by the factor, *magnitude* actions taken by the teacher. The factor *strength* refers to the expectations created by the teacher. The generality factor is the teacher's behavior (Bandura, 1991).

The bad experience of a teacher is not aware of having a self-efficacy attitude, namely belief in his ability to generate and improve his competence in a better direction (Bafadal et al., 2019). *self-efficacy* is Teacherbelieved to be able to influence teachers in carrying out their duties and responsibilities, increase their competence, provide a lively and interactive learning atmosphere, increase students' motivation and interest in learning (Warner & Kaur, 2017). Efficacy plays a very big role in teacher motivation and performance (Cherniss, 2017). Furthermore (Kim & Beehr, 2017) mentions that self-efficacy will encourage the various potentials possessed by individuals to become better.

Teachers' self-confidence refers to what they believe about themselves. Unbalanced self-efficacy affects production power. A teacher with low self-efficacy is at risk for carrying out a profession that lies at the bottom of his real skill level. He has the intention that if he can only be in a profession that lies at that level, and feels unsure about developing a profession with greater seriousness. (Park et al., 2019) various ways are used by teachers to remain professional in devoting themselves. In addition, (Sciarappa & Mason, 2014) policies to improve the quality of human resources in junior high schools continue to be pursued to continue to improve teacher competence and professionalism through strengthening self-efficacy to comply with standards set by the government, towards the era of competition.



the 5<sup>th</sup> ICTROPS  
International Conference  
for Tropical Studies and Its Applications

Islamic Development Bank 4in1 Project  
Project Implementation Unit  
University of Mulawarman



IsDB  
البنك الإسلامي للتنمية  
Islamic Development Bank



## Results and Discussion

The low *self-efficacy* of teachers in carrying out their duties to always develop themselves as professional teachers, so that efforts to achieve teacher professionalism are still lacking. From the results of interviews, it was found that 29% of teachers had difficulties in developing professionalism due to limited online learning facilities during the COVID-19 pandemic. In general, students have limited data packages, gadget facilities, and network support which are often problematic for students so that they also have an impact on teachers. On the one hand, the teacher has the desire to realize himself as a professional teacher because the undergraduate requirements have been met. Various obstacles were faced by teachers in professional development during the pandemic. However, it is necessary to consider Bandura's theory which states that *self-efficacy* teachers the teacher's belief in his own ability to carry out aspects of planning, organizing, and active teacher action to realize educational goals.

Teachers have not passed certification as a symbol of professionalism, so the steps taken are trying to become professional. . In general, all respondents have had an S1 or D4 education level and some are even 50 years old and above with a minimum service period of 20 years, but there are 36% of teachers who have not been certified as respondents in this study. Certification programs for teachers can be pursued through competency tests in the form of portfolio assessments and teacher professional education. For teachers who pass the competency test through portfolio assessment, immediately get an educator certificate, while for those who have not passed, they are required to take teacher professional education and training (PLPG) which ends with a competency test.

Teachers who pass the competency test are given an educator certificate and those who have not passed are allowed to take the re-examination twice. In addition, some teachers are exempt from the certification process and only verified documents, namely teachers who have an education level of S2 or S3 and are already in class IV/b and teachers who already have class IV/c directly obtain an educator certificate. (Kim & Beehr, 2017) mentions that self-efficacy will encourage the various potentials possessed by individuals to become better.

For teachers who already have an educator certificate as a symbol of professional teachers, they are entitled to a professional allowance of one time of basic salary. Besides that, educational components such as curriculum, students, infrastructure, methods, and learning media also play a role in supporting the success of education. While teachers who have been certified have not shown a significant increase in professionalism, the attitude of teachers in implementing the certification policy appears to be merely pursuing welfare, while teaching quality has received less attention. In order to develop teacher professionalism on an ongoing basis, it is necessary to know the real indicators of professional teachers. As (Park et al., 2019) stated that there are various ways that teachers do to remain professional in devoting themselves.

With regard to the development of teacher professionalism problems can occur because it is caused by several factors such as Ertürk, (2022) stated caused by teacher fatigue as the impact of problems, the shortness of carrying out tasks, shrinking ability and willingness to carry out activities, shrinking body commitment, pressure of mind and anxiety, loneliness, unhappiness, cynicism, depreciation of encouragement, the shortness to arrive at school, the willingness to leave school, leny Right attitude, self-revocation, and anger. Not only that, one of the research results that is very meaningful says the importance of conducting efficient communication, the implementation of obligations and responsibilities in a way that fits the duration, suitability of the body, the attitude of teachers and administrators that are in accordance with the rules of work ethics and business ethics, team cooperation and cooperation in schools that do not have clashes. A committed teacher manifests himself as a professing teacher.

A teacher who is committed to realizing himself as a professional teacher will apply: 1) has the willingness to implement the vision and mission of the school; 2) have a good personality; 3) have a commitment to work



hard, high confidence, trustworthiness and respect for others srta discipline.

Lack of teacher attention to discipline is even found in teachers who are late for school and also go home early. During the COVID-19 pandemic, schools have scheduled teachers, in turn, every day to enforce government regulations regarding the spread of COVID-19. When the teacher has a teaching schedule and at the same time as a picket schedule, online learning takes place at school. Therefore, the school first facilitates facilities in the form of WIFI, laptops, Android, and PCs (personal computers) and ensures a strong network to support online learning.

The emphasis on student discipline in online learning cannot be forced considering the many obstacles encountered in implementation. For example, when online learning is carried out, suddenly the network has problems, synchronous learning shifts asynchronously or teachers can use WhatsApp in learning. Or it can be replaced by giving assignments with the intention that students continue to carry out learning independently at home. The application of discipline during the COVID-19 pandemic is situational.

It was found that there were teachers who did not implement online learning based on a predetermined schedule, but the teacher only gave assignments. Almost all respondents experienced the same condition. When the network conditions are problematic or there are complaints from participants that they run out of data packets. So the school opens the option by preparing a Student Worksheet (SW) by the teacher concerned so that students can go to school, take the SW and return it offline based on a mutual agreement between students and teachers.

SW is a means to assist and facilitate teachers in teaching and learning activities so that effective interaction is formed between students and teachers. Besides that, it can also increase students' independent activities in learning and student learning achievements. The teacher in preparing the SW is part of the teacher's task as a facilitator. But of course, the teacher asks the SW to be adapted to the learning conditions that will be faced by students and teachers.

There are 90% of teachers think that through assignments such as SW students will benefit 1) making students more active in learning at home; 2) create independence and sincerity; 3) the character of responsibility is formed; 4) create closeness between children and parents because when students find difficulties, they will ask parents for directions; 5) have the initiative and ideas to want to learn, and 6) create confidence in the teacher to always have a good feeling that the tasks given to students are done by themselves.

The teacher's inability to master technology is due to limited infrastructure. Based on the results of interviews, data obtained that there are 60% of low teacher abilities in mastering technology in online learning during the COVID-19 pandemic. Among them some have never used a laptop, teaching by using the internet network. This situation causes the teacher to only provide references in the form of material and assignments. According to Zhang, (2021) The obstacles faced by teachers are a negative impact of online learning even though it is euphoria for 21st-century learning. In addition, teachers who master multimedia technology and system design will increase students' interest in learning so that the effect of classes also increases significantly.

## Conclusions

The experience of *self-efficacy* teachers to remain professional is still doubtful and even causes stress, because teachers are increasingly busy and work hard to prepare and ensure effective learning. The practical implication is that the results of future research can be tested by teachers in high school.

## ACKNOWLEDGMENT

We and the research team would like to thank the Islamic Development Bank (IsDB) Mulawarman University for facilitating this research fund in 2021 [405/UN17.11/PL/2021]

## REFERENCES

- Bafadal, I., Nurabadi, A., Sobri, AY, & Gunawan, I. (2019). The competence of beginner principals as instructional leaders in primary schools. *International Journal of Innovation, Creativity, and Change*, 5(4), 625–639.
- Bandura, A. (1982). *Self-Efficacy Mechanism in Human Agency*. 37(2), 122–147.
- Bandura, A. (1991). Social cognitive theory of self-regulation. *Organizational Behavior and Human Decision Processes*, 50(2), 248–287. [https://doi.org/10.1016/0749-5978\(91\)90022-L](https://doi.org/10.1016/0749-5978(91)90022-L)
- Bento, SGTDFNLSRBLA, Wing, KISC, & Working. (2020). *Tracking Public And Private Responses To The Covid-19 Epidemic: Evidence From State And Local Government Actions*.
- Cherniss, C. (2017). Role of professional self-efficacy in the etiology and amelioration of burnout. In *Professional burnout* (pp. 135–149). Routledge.
- Copeland, WE, McGinnis, E., Bai, Y., Adams, Z., Nardone, H., Devadanam, V., Rettew, J., & Hudziak, JJ (2021). Impact of COVID-19 pandemic on college student mental health and wellness. *Journal of the American Academy of Child & Adolescent Psychiatry*, 60(1), 134–141.
- Courtemanche, BC, Garuccio, J., Le, A., Pinkston, J., & Yelowitz, A. (2020). *Strong Social Distancing Measures In The United States Reduced The COVID-19 Growth Rate*. 1–8. <https://doi.org/10.1377/hlthaff.2020.00608>
- Dahl, T. (2019). Prepared to teach for sustainable development? Student teachers' beliefs in their ability to teach for sustainable development. *Sustainability (Switzerland)*, 11(7). <https://doi.org/10.3390/su11071993>
- Fessell, D., & Cherniss, C. (2020). Coronavirus disease 2019 (COVID-19) and beyond: micro-practices for burnout prevention and emotional wellness. *Journal of the American College of Radiology*, 17(6), 746.
- Frutos, R., Serra-Cobo, J., Chen, T., & Devaux, CA (2020). COVID-19: Time to exonerate the pangolin from the transmission of SARS-CoV-2 to humans. *Infection, Genetics, and Evolution*, 84, 104493.
- Gerick, J., Eickelmann, B., & Bos, W. (2017). School-level predictors for the use of ICT in schools and students' CIL in international comparison. *Large-Scale Assessments in Education*, 5(1). <https://doi.org/10.1186/s40536-017-0037-7>
- Kartadinata, S., Suherman, U., & Saripah, I. (2011). *Exploring The Values Of Peace In The Cultural Contexts Of Indonesian And Finnish Schools: A Study Of The Development Of Peace Pedagogy*. 96(5), 1485–1504.
- Kim, M., & Beehr, TA (2017). Self-Efficacy and Psychological Ownership Mediate the Effects of Empowering Leadership on Both Good and Bad Employee Behaviors. *Journal of Leadership and Organizational Studies*, 24(4), 466–478. <https://doi.org/10.1177/1548051817702078>
- Kunesh, CE, & Noltemeyer, A. (2015). *Understanding Disciplinary Disproportionality: Stereotypes Shape Pre-Service Teachers ' Beliefs About Black Boys ' Behavior*. <https://doi.org/10.1177/0042085915623337>
- LJ Siegel, BW (2014). *CRJU 3400 Juvenile Delinquency and Justice [ Term ]*. xxx.
- Miles, MB, & Huberman, AM (1994). *Qualitative data analysis: An expanded sourcebook*. sage.



International Conference  
for Tropical Studies and Its Applications

Islamic Development Bank 4in1 Project  
Project Implementation Unit  
University of Mulawarman



IsDB  
البنك الإسلامي للتنمية  
Islamic Development Bank



- Park, J.-H., Lee, IH, & Cooc, N. (2019). The role of school-level mechanisms: How principal support, professional learning communities, collective responsibility, and group-level teacher expectations affect student achievement. *Educational Administration Quarterly*, 55(5), 742–780.
- Perren, S., Herrmann, S., Iljuschin, I., Frei, D., Körner, C., & Sticca, F. (2017). Early Childhood Research Quarterly Child-centred educational practice in different early education settings: Associations with professionals' attitudes, self-efficacy, and professional background. *Early Childhood Research Quarterly*, 38, 137–148. <https://doi.org/10.1016/j.ecresq.2016.07.001>
- Retnawati, H., Yogyakarta, UN, Djidu, H., & Kartianom, K. (2018). *Teachers' knowledge about higher-order thinking skills and their learning strategy*. April. <https://doi.org/10.33225/pec/18.76.215>
- Sato, T., Tsuda, E., McKay, C., Furuta, Y., & Kajita, K. (2020). Japanese Elementary Teachers' Learning Experiences of Physical Education Professional Development. *The Teacher Educator*, 55(4), 373–391. <https://doi.org/10.1080/08878730.2020.1801925>
- Sciarappa, K., & Mason, CY (2014). National principal mentoring: does it achieve its purpose? *International Journal of Mentoring and Coaching in Education*.
- Solar, H., & Dockendorff, M. (2019). *International Journal of Mathematical Education in Science and Technology ICT integration in mathematics initial ...* <https://doi.org/10.1080/0020739X.2017.1341060>
- Warner, S., & Kaur, A. (2017). The Perceptions of Teachers and Students on a 21st Century Mathematics Instructional Model. *International Electronic Journal of Mathematics Education-ISSN: 12(2)*, 193–215.
- Winberg, C., Adedorff, H., Bozalek, V., Conana, H., Pallitt, N., Wolff, K., Olsson, T., & Roxå, T. (2018). *Learning to teach STEM disciplines in higher education: a critical review of the literature*.
- Yuanita, L., Ibrahim, M., & Prahani, BK (2019). *Journal of Technology and Science Education Innovative Chemistry Learning Model: Improving The Critical Thinking Skill And Self-Efficacy Of Pre-Service*. 9(1), 59–76.
- Zhao, L., & Liu, X. (2021). *The Differentiate Effect of Self-Efficacy, Motivation, and Satisfaction on Pre-Service Teacher Students' Learning Achievement in a Flipped Classroom: A Case of a Modern Educational Technology Course*.

## SEE-419

### Analysis of Health Level In Infants And Toddlers In The Midst Covid-19 Pandemic In Petung Sub-District, Penajam Paser Utara Region: Social And Health Phenomenon

Anggriya Feby Setyowati<sup>1</sup>, Alamsyah<sup>2</sup>

<sup>1</sup>The Faculty of Mathematics and Natural Science Mulawarman University

<sup>2</sup>Faculty of Cultural Science Mulawarman University

Corresponding Author\* : Anggriya20@gmail.com

#### Abstract

Health services for mothers and children are among those affected by the Covid-19 pandemic that has hit the world since the end of 2019 and began to enter Indonesia in early 2020. Maternal and child health programs (MCH) are considered not to be running well. so that Indonesia is one of the countries with the highest MMR in ASEAN. This study uses a descriptive research method using a qualitative approach. The place of research is the Petung-Public Health Center (P-PHC), Penajam Paser Utara Regency. This research is intended to provide information and analyze comparisons related to health status in MCH services, especially in the health of young infants and toddlers before and after the Covid-19 pandemic, and hopes that in the future health services will be better good. The impact of the Covid-19 pandemic was quite detrimental to the growth and development of children throughout the Petung Sub-District. Immunization activities in Petung were quite experiencing problems. As for immunization itself, it was intended that infants, toddlers and children could protect against various diseases in the future and help build special antibodies to fight certain diseases. As a result, young infants, toddlers and children who are not immunized are very at risk of developing complications of diseases related to the immune system of children in the future.

**Keywords:** Young Infants, Toddlers, Immunization

#### Introduction

The Covid-19 case in July 2021 has reached 3.24 million, with 2.6 million recovered cases and 85,835 deaths. In East Kalimantan, it has 109,814 confirmed cases and 3,030 deaths. COVID-19 infection can cause mild, moderate or severe symptoms. The main clinical symptoms that appear are fever (temperature > 380 ), cough and difficulty breathing. In addition, it is accompanied by severe shortness of breath, fatigue, myalgia, gastrointestinal symptoms such as diarrhoea and other respiratory symptoms. In severe cases rapidly and progressively worsens, such as ARDS, septic shock, uncorrected metabolic acidosis and bleeding or coagulation system dysfunction within a few days. In some patients, symptoms appear mild, not even accompanied by fever. Most patients have a worthy prognosis, with a small proportion in critical condition and even death (Rahmi et al., 2020).

Maternal and child health is health that includes all aspects to maintain optimal health degrees comprehensively in every cycle of life starting from pre-conception, conception, pregnancy, childbirth, postpartum, newborn, toddler, pre-school, school, adolescent, adult to menopause.

Midwifery services are an integral part of the health care system provided by midwives, carried out independently, in collaboration, consultation and referrals aimed at women's reproductive health throughout their life cycle, including infants and toddlers (Depkes.go.id, 2012).

Health development is the implementation of health efforts by the Indonesian people, to increase awareness, willingness, and ability to live healthy for everyone, to realize the highest degree of public health. Definition of health Based on the Law of the Republic of Indonesia no. 36 of 2009 concerning Health Article 1 Health is a state of health, both physically, mentally, spiritually and socially that enables everyone to live socially and economically productive lives. Puskesmas is one of the technical implementing units of the district/city health office which is in charge of implementing health development for the community. The health efforts carried out include environmental health promotion, maternal and child health efforts and family planning, efforts to improve community nutrition, prevention and eradication of infectious diseases and treatment efforts (Mutiawati et al., 2015).

Immunization is an effort to provide immunity to infants and children by introducing vaccines into the body so that the body makes antibodies to prevent certain diseases. The purpose of immunization itself is to provide immunity to the baby's body by giving vaccines. Vaccines come from certain germs that can cause disease, but these diseases are first weakened or killed so that they are not dangerous when inserted into the human body. The diseases targeted by this vaccine are diphtheria, polio, tuberculosis, tetanus, pertussis and hepatitis B (Wawomeo et al., 2019).

Basic immunization in infants should be given to children according to their age. As in this condition, the immune system is expected to work optimally. every baby is required to receive complete basic immunization consisting of 1 dose of BCG, 3 doses of DPT-HB and/or DPT-HB-Hib, 4 doses of polio, and 1 dose of measles. Of the complete basic immunizations that are required, measles is the immunization that gets more attention, this is following Indonesia's global commitment to maintain high and evenly distributed measles immunization coverage. However, under certain conditions, some babies do not get complete basic immunizations. As we know, that in society there are still different understandings about immunization, so there are still many babies and toddlers who do not get immunization services. The reasons given by parents regarding this were because their children were afraid of heat, often got sick, the family did not allow it, the immunization place was far away, did not know where the immunization was and so on (Safitri, 2019).

The Large-Scale Social Restriction Policy (PSBB) including in North Penajam Paser Regency was also implemented as an effort to prevent the transmission of Covid-19 by involving various elements of the community, government, medical personnel and the TNI/POLRI. Because this causes a significant impact on health services at the Petung Health Center, one of which is Maternal and Child Health. The impact of the Covid pandemic has caused various services for pregnant women and newborns to be hampered, such as pregnancy checks and immunizations for babies. This is because many pregnant women and mothers of babies are worried about being in public places during this pandemic.

Until now, knowledge about COVID-19 infection concerning maternal and child health is still limited and there are no specific recommendations for handling COVID-19. Based on these limited data and several examples of cases in the treatment of previous Coronaviruses (SARS-CoV and MERS-CoV)

and some cases of COVID-19, it is believed that mothers and children have a higher risk of serious illness, morbidity and mortality compared to the general population. (Rohani et al., 2020).

## Methods

This study used a descriptive research method with a qualitative approach. The place of research was Petung Public Health Center, North Penajam Paser Regency. This study was conducted in July 2021. The two informants in this study came from medical personnel at the Petung Health Center. The researchers themselves were assisted with additional instruments in the form of interview guides, voice recorders and writing instruments. The data collected was secondary data.

## Results and Discussion

This study was conducted by interviewing medical personnel at the Petung Health Center, Penajam Paser Utara Regency. Due to the COVID-19 pandemic, visits to the Puskesmas are very limited due to reduced mobility and crowds occur in one place. So that the sources are taken only from existing medical personnel and administrative data sources of Petung-Public Health Center (P-PHC), Penajam Paser Utara Regency.

The time used in the comparative analysis of this data was data before the pandemic in 2019 and data during or post-pandemic 2020. The subject of observation were infants and toddlers in Petung Sub-District in Kutai Karta Negara Regency.

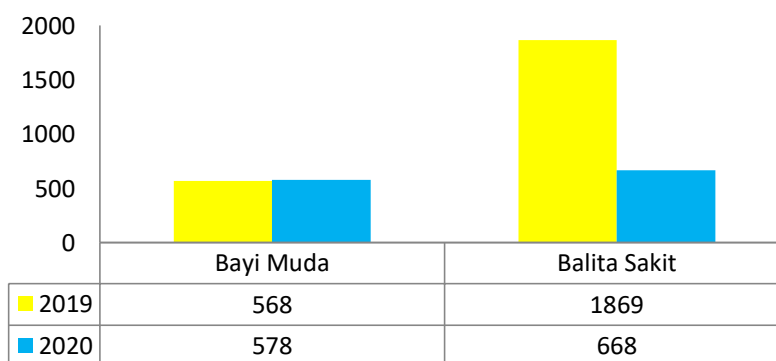
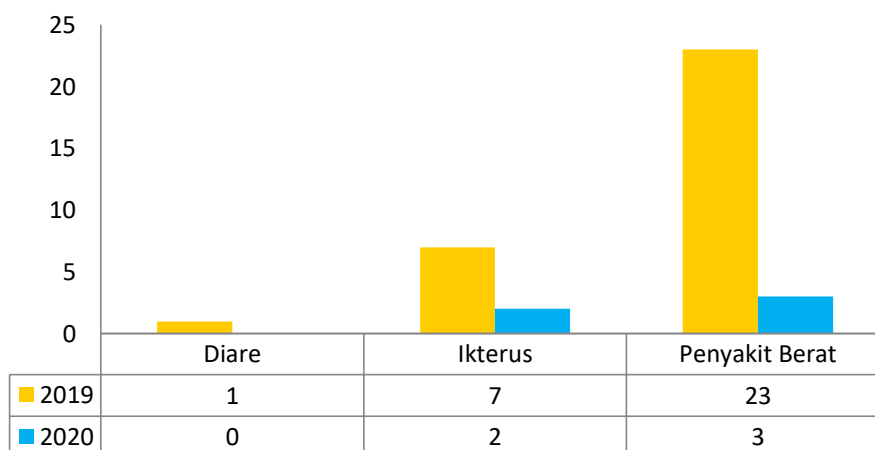

**Figure 1.** Visitation at Petung Health Center

Based on the data in Figure 1, visits by young infants (aged 0-2 months) before the pandemic at MCH Petung-Public Health Center were 568 babies, while after the pandemic there were 578 babies. This indicated an increase in visits of 1.7%. It was influenced by the increasing number of pregnancies and births in the working area of the Petung-Public Health Center during the pandemic

Although young infants experienced an increase in visits, this was different from visits for toddlers to MCH Petung Health Center. Prior to the pandemic, visits by toddlers (Age 2 months – 5 years) to MCH Petung Health Center reached 1869 toddlers, while during the pandemic there were only 668 toddlers. This has decreased by 64.3%. This decline occurred due to several factors, namely, the

existence of restrictions on visits to each poly including KIA, the concern of mothers to bring their toddlers to public places or crowds during the pandemic, as well as the existence of digital advances where mothers can consult with doctors through applications or home visits by a doctor outside the health centre.

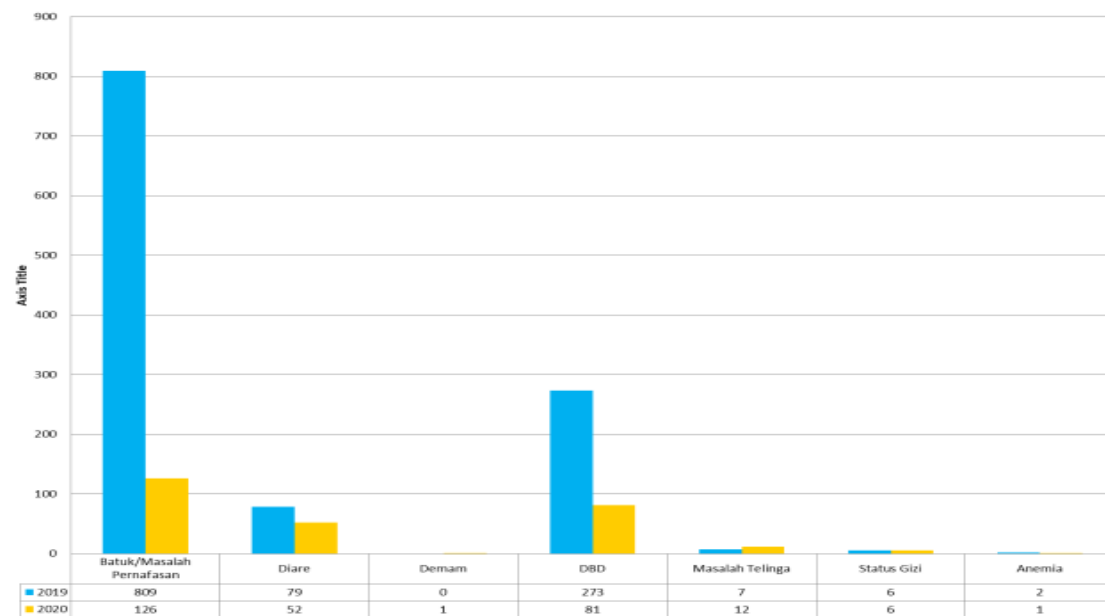

**Figure 2.** Complaints in infants and toddlers at the Petung Health Center

Based on the data on visits by infants and toddlers before and after the pandemic in Figure 1, it can also be seen how the data on the percentage of complaints in infants and toddlers at the Petung Health Center is shown in Figure 2. In infant complaints (aged 0 – 2 months) complaints in infants are divided into 3; diarrhoea, jaundice and serious illness. Before the pandemic, there was 1 infant who complained of diarrhoea in young infants, while during the pandemic there were 0. This means that there was a 100% decrease in cases. There were 7 cases of jaundice (jaundice) before the pandemic and 2 cases after the pandemic, resulting in a 71.4% decrease in cases. For complaints of severe illness, before the pandemic there were 23 cases, while after the pandemic there were 3 cases, there was a decrease in cases of 86.9%.

Based on existing data, it can be seen that before the pandemic, 5.45% of young infants visited the Petung Health Center with complaints of illness, while 94.55% of young infants had no complaints of certain diseases and 92.9% of young infants received immunization injections. Complete Basics (IDL) on time at the Public Health Center (PHC) and Community Health Care. Meanwhile, during the pandemic, 0.8% of infants had complaints of illness during visits to the Public Health Center, while 99.2% of other infant visits had no specific complaints and for Complete Basic Immunization (IDL) as many as 83% of young infants received immunizations but with protocols and schedules. which has been strictly determined by medical personnel and was only performed at the PHC.

In the complaints of toddlers (aged 2 months – 5 years) in Figure 3, complaints in toddlers are divided into 7; Cough/respiratory complaints, diarrhoea, fever, Dengue Fever (DHF), ear problems, nutritional status and anaemia.



**Figure 3.** Complaints in infants and toddlers

Before the pandemic, complaints of coughing or breathing problems occurred in 809 toddlers while during the pandemic 126 toddlers. Then the percentage decrease in cases is 84.4%. Complaints concerning diarrhoea before the pandemic were 79 toddlers and after the pandemic, there were 52 toddlers, the percentage decrease in cases was 34.2%. For complaints of fever before the pandemic, there were 0 toddlers and after the pandemic, there was 1 toddler, likewise, there was an increase in the percentage of cases by 100%.

Complaints on Dengue Fever (DHF) before the pandemic were 273 toddlers and after the pandemic, there were 81 toddlers, there was a decrease in cases of 70.3%. Complaints regarding ear problems before the pandemic were 7 toddlers and after the pandemic, there were 12 toddlers, there was a 41.7% increase in cases. Complaints concerning nutritional status before the pandemic were 6 toddlers and after the pandemic as many as 6 toddlers. Then the percentage of these complaints is 0%. Complaints about anaemia before the pandemic were 2 toddlers and after the pandemic, there was 1 toddler, this indicates an increase in cases of 50%.

For immunization for toddlers and children, there are significant obstacles related to immunization. For measles immunization for toddlers (under 2 years old) at the beginning of the pandemic, immunization at the Petung Health Center was abolished because it reduces physical touch and avoids babies and toddlers being in crowds. For grade 1 and grade 2 elementary school children from 2020 to 2021 also cannot obtain measles and Td immunization. Because in previous years, this immunization was conducted on a schedule with each elementary school. The delay in immunization for elementary school children is also constrained if they come directly to the PHC, there are fears that there will be crowds. In addition, medical officers at the Petung Public Health Center are also limited, because they have to divide services in each poly, handling Covid-19 and procuring Covid Vaccination in Petung.



## Conclusion

The impact of the Covid-19 pandemic is very detrimental to the growth and development of children throughout Indonesia. Immunization itself aims so that infants, toddlers and children can protect against various diseases in the future and help build special antibodies to fight certain diseases.

It can be concluded that before the pandemic, 66.3% of toddlers visited MCH in Petung Public Health Center (PHC) with disease complaints. Meanwhile, 33.7% of healthy toddlers have no complaints of disease. Meanwhile, during the pandemic, 41.8% of toddlers had complaints of illness during visits to the PHC, while 58.2% of other toddlers' visits had no specific complaints.

With the delay in the implementation of immunization for grade 1 and 2 elementary school children in the working area of the Petung-Public Health Center, it is feared that children in Petung Village do not have strong antibodies like children who receive measles and Td immunization injections. Because of this, the Petung-Public Health Center prioritizes immunization of infants and toddlers because they are more vulnerable and this immunization can be minimized from the crowd by being held at Posyandu scattered in Petung Village.

## References

- Mutiawati, C., Wahid, A., Engkeng, S., Lampus, B. S., Kesehatan, F., Universitas, M., Ratulangi, S., & Abstrak, M. (2015). *Overview of Maternal and Child Health Services (KIA) at the Tuminting Health Center in Manado City*.
- Rahmi, J., Romlah, S. N., Listiana, I., Handayani, P., Darmayanti, D., Arimurti, I. S., Holiday, H., & Kasumawati, F. (2020). *Mother and Child Health in the Era of the Corona Virus Disease (Covid-19) Pandemic*. *Jam: Jurnal Abdi Masyarakat*, 1(1), 62–69.
- Rohani, S., Ana, E. F., Qurniasih, N., Wulandari, E. T., Sulistiawati, Y., Kumalasari, D., Mayasari, A. T., & Utami, I. T. (2020). *The Development of Maternal and Child Health Research During the COVID-19 Pandemic*. *Journal of Community Service Ungu ABDI KE UNGU*, 2(2), 85–89. <http://journal.aisyahuniversity.ac.id/index.php/Abdi>
- Safitri, S. (2019). *Counseling on the Importance of Immunization for Babies at the Posyandu Kasih Ibu in Pelawan Village, Pelawan District, Sarolangun Regency*. *Jurnal Abdimas Kesehatan (JAK)*, 1(2), 99. <https://doi.org/10.36565/jak.v1i2.32>
- Wawomeo, A., Taneo, N. A., & Kambuno, N. T. (2019). *Relationship between Knowledge Level and Mother's Attitude towards Compliance with Basic Immunization*. *Jurnal Kesehatan Primer*, 4(2), 4–91. <http://jurnal.poltekeskupang.ac.id/index.php/jkp%0A>

## SEE-425

# Exploring Pre-service Teachers Trust in Science-Technology-Engineering-Mathematics (STEM) during the COVID-19 Pandemic

Lola Jovita<sup>1</sup>, Riski Amalia<sup>1</sup>, Shelly Efwindi<sup>1</sup>, Nurul Fitriyah Sulaeman<sup>1\*</sup>

Department of Physics Education, Mulawarman University, Indonesia

Corresponding Author\*: [nurul.fitriyah@fkip.unmul.ac.id](mailto:nurul.fitriyah@fkip.unmul.ac.id)

### Abstract

When cases of pandemic diseases are made public, unavoidable discussions arise about the public loss of trust in Science-Technology-Engineering-Mathematics (STEM). The discussion about trust in STEM reaches far beyond the pandemic itself. It is fundamental for shaping the public understanding of science. Through their science classroom, pre-service science teacher plays an essential role to developed students trust to STEM. Therefore, it is valuable to exploring pre-service science teacher trust in STEM. Our research was carried out on 132 pre-service science teachers (23 male and 109 female) in a state university in Indonesia. Data was collected with the questionnaire called “Trust in Science and Scientist Inventory” which consists of 20 items. We analyzed the data by categorizing, tabulating, and conducting descriptive statistics to the data. Further analysis to explore the possible different levels of trust by gender was also estimated and confirmed by an independent t-test. From the result, the participants demonstrated a neutral level of trust in STEM. Comparisons by gender showed that male pre-service science teachers had a more positive level than female pre-service teachers. Still, the statistical result showed the difference is not significant. The results indicate the need to enhance knowledge of the latest issues in STEM for a pre-service science teacher to develop their trust. We argue that trust is related to the content knowledge about science. The relation between trust and content knowledge in science is valuable to explore in future research.

**Keywords:** STEM, Trust, Pre-service Science Teacher

### Introduction

The development of science and technology cannot be separated from society and culture, with all the norms, values, meanings, beliefs, habits, and mentalities built into them. Trust in science can influence and greatly impact every activity people carry out in everyday life. Trust is a feeling that is based on emotions, knowledge, beliefs, and relationships (Nadelson et al., 2014). Some belief theorists argue that trust is only based on a person's knowledge who can understand the actual risks and benefits associated with that individual (Critchley, 2008). Research conducted by scientific scientists has brought many benefits to people in everyday life. Public trust in science and scientists must be the top priority of science. In line with this, surveys show that people around the world have a close high level of trust in science and scientists (Pew, 2019). Society in today's era where knowledge has been so developed is very dependent on science and technology (Luhmann, 1979). Several other studies have shown that public trust during the COVID-19 pandemic has increased. This is because people are starting to pay attention to news related to vaccine testing and development (Zingg & Siegrist, 2012; Rochman & Pertiwi, 2020). It is undeniable that the public's dependence on information in the media continues to increase during the pandemic because the need for the latest information about COVID-19 continues to be awaited and monitored globally (Battiston et al., 2021). In addition, a potential lack of understanding of scientific knowledge is common in society and can be described as a lack of trust in science and scientists (Miller, 2008). Some scientific practices that are seen by the public do not match those of

scientific scientists (Tourney, 1992). This is due to the depictions scientists make on television, film, the internet, books, and other media that can yield strong but potentially inaccurate scientific insights. (Rahm & Charbonneau, 1997; Wyer et al., 2010). Therefore, the practice of science carried out by scientific scientists greatly influences public confidence in science (Finson, 2001).

STEM education is essential for students to survive in the modern era to compete and survive in today's developments. Therefore, students must be prepared with several skills, including the ability to adapt to many situations, communicate at a higher level, and solve problems. It can be obtained by students from STEM Education (Rifandi et al., 2020). STEM education has become a trending topic to be discussed among education experts. One of the preparations in implementing STEM education is to prepare the skills of the prospective teacher. Specifically, the teacher is the person who will implement or integrate STEM education in classroom learning. Many studies have reported that teachers' attitudes toward science teaching are a strong indicator of the quality and quantity of science taught to a student (Russell, 1986; Wallace & Loudon, 1992). Teachers who have low confidence in teaching science also develop negative attitudes toward science (Koballa & Crawley, 1985). Teachers who have low trust will eventually avoid teaching science (Ngman-wara, 2016). However, data on teacher candidate trust in STEM is currently still limited (Rifandi et al., 2020). To increase the trust of pre-service teachers, it should be appropriately considered in teacher preparation programs (Tosun, 2000). What can be done is make STEM education an integral part of the preparation of prospective teachers at the university level (Preciado Babb et al., 2016).

Research related to STEM often mentions differences in answers between male and female students. Less than half of men in the U.S. have a bachelor's degree in science (Cheryan et al., 2016). This indicates that there is a difference in trust in STEM between male and female science teacher candidates. According to a World Bank report, the number of women in STEM continues to decline from high school to university, then continued in work in the laboratory, teaching and research and technology policymakers (Candraningrum, 2016; Sadler et al., 2012). Globally it is reported that there are only 30% of women in STEM, and in Asia alone, there are only 18% of women. One of the reasons women believe in science is the bias in the material, curriculum, and strong stereotypes in society that girls are not suitable for STEM (Halpern et al., 2007).

It is important to understand how people rely on scientists and scientists to trust information during the ongoing COVID-19 pandemic (Battiston et al., 2021). In addition, knowing the level of trust in science is essential to enable researchers to explore the relationship between belief and various personal characteristics, such as level of education and involvement in science, and personal worldviews, such as political philosophy or religiosity (Nadelson et al., 2014). Therefore, researchers want to reveal the pre-service teachers' trust in STEM during the COVID-19 pandemic. Analyzing prospective science teachers' trust in STEM and whether or not prospective teachers continue to pursue science work can help in planning the importance of instilling STEM at the college stage.

## Methodology

This research is included in quantitative research. Quantitative research can be interpreted as research based on the philosophy of positivism, used to examine assured populations or samples, data collection using research instruments, data analysis is quantitative or statistical to test predetermined hypotheses (Sugiono, 2012). The research design used is descriptive. The purposive sampling technique was used to obtain samples from 132 science teacher candidates (23 male and 109 female) in the first year of class 2020 from students of Biology Education, Mathematics Education, and Chemistry Education, Mulawarman University. For this study, the data to be taken is to analyze the level of confidence in STEM during the pandemic COVID-19 and analyze the presence or absence of significant differences based on gender. This questionnaire uses a 5-level

Likert scale, namely strongly agree, agree, neutral, disagree, and strongly disagree, with the types of positive and negative questions. The following is the score for each question in the questionnaire given:

**Table 1. Scoring System**

Answer	Score	
	Positive	Negative
Strongly Agree	5	1
Agree	4	2
Neutral	3	3
Disagree	2	4
Strongly Disagree	1	5

### Data Analysis Technique

Descriptive analysis used a descriptive analysis of percentages. The first step is to convert the answers into scores. The highest score is 5, and the lowest score is 1. After that, we calculated the average and standard deviation. Next, determine the ideal minimum total score. In this study, the ideal minimum total score is 20 (the minimum score for each item is 1 with the number of items in the questionnaire), while the ideal maximum total score is 100 (the maximum score for each item is 5 with the number of items in the questionnaire). To find out the percentage level of pre-service teachers trust in STEM during the COVID-19 pandemic using descriptive statistical analysis methods, the percentage an obtained by the following formula:

$$\text{score percentage \%} = \frac{\text{total score of respondents}}{\text{the number of ideal answer score}} \times 100\% \quad (1)$$

The results of the calculation data with the above formula are then defined by grouping the value intervals and completing them with categories. In this study, five class intervals have has been determined, namely starting from very low, low, medium, high, and very high (Table 2).

**Table 2. Class Interval 5 Categories**

Interval	Categories
$X < M - 1,5SD$	Very Low
$M - 1,5SD < X \leq M - 0,5SD$	Low
$M - 0,5SD < X \leq M + 0,5SD$	Currently
$M + 0,5SD < X \leq M + 1,5SD$	High
$M + 1,5SD < X$	Very High

(Rohman, 2016)

## Results and Discussion

The number of respondents who have filled out a questionnaire on the trustworthiness of prospective science teacher teachers in STEM during the COVID-19 pandemic is 132, with the number of female respondents being 109 and male respondents being 23. The following is the percentage level of trust of prospective science teachers in STEM during the COVID-19 pandemic.

**Table 3.** Data Distribution

Interval	Frequency	Percentage	Category
20-36	6	4%	Very low
37-53	41	31%	Low
54-70	47	35%	Neutral
71-87	29	22%	High
88-104	9	7%	Very high

The results above show that the Science Teacher Candidate Trust Score on STEM during the Covid-19 Pandemic is in the medium category with a percentage of 35%. To further clarify the results, it is necessary to carry out a Normality test and Homogeneity Test to see normally/not distributed data and have the same/different variance by collecting the results of female and male respondents.

**Table 4.** Results of Normality Test

**One-Sample Kolmogorov-Smirnov Test**

		Male	Female
<b>N</b>		23	109
<b>Normal Parameters<sup>a,b</sup></b>	<b>Mean</b>	64.74	62.39
	<b>Std. Deviation</b>	8.874	5.144
<b>Most Extreme Differences</b>	<b>Absolute</b>	.122	.086
	<b>Positive</b>	.059	.084
	<b>Negative</b>	-.122	-.086
<b>Test Statistic</b>		.122	.086
<b>Asymp. Sig. (2-tailed)</b>		.200 <sup>c,d</sup>	.044 <sup>c</sup>

Based on the results in the output table above, it can show that the data a normally distributed.

**Table 5.** Results of Homogeneity Test

**Test of Homogeneity of Variances**

Score	Levene Statistic	df1	df2	Sig.
<b>Based on Mean</b>	12.632	1	130	.001
<b>Based on Median</b>	12.174	1	130	.001
<b>Based on Median and with adjusted df</b>	12.174	1	108.079	.001
<b>Based on trimmed mean</b>	12.806	1	130	.000

The table above shows the significant value, which is 0.000, meaning less than 0.05, indicating that the data group has different variances or is not homogeneous. Even though the results show that they are not homogeneous, the independent sample T-Test can still be done. The following are the results of an unpaired T-Test to see the difference in the level of trust between female respondents and male respondents in STEM during the COVID-19 pandemic.

**Table 6.** Descriptive Statistics by Gender

Score	Gender	N	Group Statistics		
			Mean	Std. Deviation	Std. Error Mean
			Male	23	64.7391
Female	109	62.3945	5.14425	.49273	

The results above show in table 5 in the Group Statistics Table, and it is known that the average score for male respondents is 64.7391, and the average score for female respondents is 62.3945.

**Table 7.** Independent T-Test

Score	Levene's Test for Equality of Variances	Independent Samples Test								
		F		t		t-test for Equality of Means				
			Sig.		df	Sig. (2-tailed)	Mean Difference	Std. Error Difference	95% Confidence Interval of the Difference	
	Equal variances assumed								Lower	Upper
		12.632	.001	1.720	130	.088	2.34464	1.36354	-.35296	5.04223
	Equal variances not assumed			1.224	25.205	.232	2.34464	1.91483	-1.59740	6.28667

The table above shows that the difference in the level of trust between male respondents and female respondents in STEM during the COVID-19 pandemic is not significant. These results in line with the former result in the scientific literacy in context of Indonesia (Afriana et al., 2016) where the gender factor are not significantly difference. However, our results are in contrast from the Switzerland study where the gender differences showed significant results.

This research, which is about exploring Science-Technology-Engineering-Mathematics (STEM) trust in prospective science teachers during the COVID-19 pandemic, found that the trust was in the medium category with a percentage of 35%. This view is important for understanding the extent to which science and scientists are trusted to produce information that can provide certainty and explain the details of highly complex events similar to viral pandemics. (Hunter, 2020). Of course, by demonstrating the need to increase knowledge of the latest issues in STEM for science teacher candidates to develop their confidence in teaching and science learning. It is important to help pre-service teachers to acquire sufficient subject content knowledge in science to create positive attitudes towards science and science teaching (Ngman-wara, 2016). Therefore, building on the current understanding revealed in this survey, it is important to encourage teacher candidates to understand better the nature of integration and explicit relationships among disciplines (Pimthong & Williams, 2020).

## Conclusions

From the results of this study, it can be concluded that the pre-service teacher's trust in Science-Technology-Engineering-Mathematics (STEM) during the COVID-19 pandemic is overall in the moderate category with a percentage of 35%. The independent T-Test by gender showed there is no significant difference between gender. To increase the trust in the teaching efficacy of pre-service science, lecturer teachers should integrate science content in their methods science courses to increase their knowledge. Research findings indicate a

need to increase understanding of the latest issues in STEM for pre-service science teachers to develop their confidence in science teaching and learning.

## REFERENCES

- Afriana, J., Permanasari, A., & Fitriani, A. (2016). Penerapan project based learning terintegrasi STEM untuk meningkatkan literasi sains siswa ditinjau dari gender. *Jurnal Inovasi Pendidikan IPA*, 2(2), 202. <https://doi.org/10.21831/jipi.v2i2.8561>
- Battiston, P., Kashyap, R., & Rotondi, V. (2021). Reliance on scientists and experts during an epidemic: Evidence from the COVID-19 outbreak in Italy. *SSM - Population Health*, 13, 100721. <https://doi.org/10.1016/j.ssmph.2020.100721>
- Candraningrum, D. (2016). Girls in STEM (Science, Technology, Engineering, Mathematics). *Jurnal Perempuan*, 21(4).
- Cheryan, S., Ziegler, S. A., Montoya, A. K., & Jiang, L. (2016). Why are some STEM fields more gender balanced than others? *Psychological Bulletin*, 143(1), 1–35. <https://doi.org/10.1037/bul0000052>
- Critchley, C. R. (2008). Public opinion and trust in scientists: The role of the research context, and the perceived motivation of stem cell researchers. *Public Understanding of Science*, 17(3), 309–327. <https://doi.org/10.1177/0963662506070162>
- Finson, K. D. (2001). Investigating preservice elementary teachers' self-efficacy relative to self-image as a science teacher. *Journal of Elementary Science Education*, 1(13), 31–42.
- Halpern, D. F., Benbow, C. P., Geary, D. C., Gur, R. C., Hyde, J. S., & Gernsbacher, M. A. (2007). The science of sex differences in science and mathematics. *Psychological Science in the Public Interest, Supplement*, 8(1), 1–51. <https://doi.org/10.1111/j.1529-1006.2007.00032.x>
- Hunter, D. J. (2020). History in a Crisis: Lessons for Covid-19. *New England Journal of Medicine*, 31(1), 1969–1973. [nejm.org](http://nejm.org)
- Koballa, T. R., & Crawley, F. E. (1985). The Influence of Attitude on Science Teaching and Learning. *School Science and Mathematics*, 85(3), 222–232. <https://doi.org/10.1111/j.1949-8594.1985.tb09615.x>
- Luhmann, N. (1979). Trust and Power. *John Wiley & Sons*.
- Miller, K. R. (2008). Only a theory: Evolution and the battle for America's soul. *New Work: Penguin Group*.
- Nadelson, L., Jorcyk, C., Yang, D., Jarratt Smith, M., Matson, S., Cornell, K., & Husting, V. (2014). I Just Don't Trust Them: The Development and Validation of an Assessment Instrument to Measure Trust in Science and Scientists. *School Science and Mathematics*, 114(2), 76–86. <https://doi.org/10.1111/ssm.12051>
- Ngman-wara, E. I. (2016). Pre-Service Basic Science Teachers' Self-Efficacy Beliefs and Attitudes towards Science Teaching. *International Journal Innovation Education and Research*, August, 20–41.
- Pew, R. C. (2019). Trust and mistrust in americans' views of scientific experts. *Technical Report*.
- Pimthong, P., & Williams, J. (2020). Preservice teachers' understanding of STEM education. *Kasetsart Journal of Social Sciences*, 41(2), 289–295. <https://doi.org/10.1016/j.kjss.2018.07.017>
- Preciado B., A. P., Takeuchi, M. A., Yáñez, G. A., Francis, K., Gereluk, D., & Friesen, S. (2016). Pioneering STEM Education for Pre-Service Teachers. *International Journal of Engineering Pedagogy (IJEP)*, 6(4), 4. <https://doi.org/10.3991/ijep.v6i4.5965>



the 5<sup>th</sup> **ICTROPS**

International Conference  
for Tropical Studies and Its Applications

Islamic Development Bank 4in1 Project  
Project Implementation Unit  
University of Mulawarman



البنك الإسلامي للتنمية  
Islamic Development Bank



- Rahm, J., & Charbonneau, P. (1997). Probing stereotypes through students' drawings of scientists. *American Journal of Physics*, 65(8), 774–778. <https://doi.org/10.1119/1.18647>
- Rifandi, R., Rahmi, Y. L., Widya, & Indrawati, E. S. (2020). Pre-service teachers' perception on science, technology, engineering, and mathematics (stem) education. *Journal of Physics: Conference Series*, 1554(1). <https://doi.org/10.1088/1742-6596/1554/1/012062>
- Rochman, C., & Pertiwi, C. S. R. (2020). Learning at Covid-19 Pandemic Era: Science Technology Engineering and Mathematic Competencies and Student Character. *SEJ (Science Education Journal)*, 4(2), 129–142. <https://doi.org/10.21070/sej.v4i2.574>
- Rohman, M. (2016). Kontribusi Status Gizi Terhadap Kemampuan Motorik Kasar Siswa Sekolah Dasar. *Fakultas Ilmu Keolahragaan Universitas Negeri Surabaya*, 4, 77–84.
- Roten, F. C. von. (2004). Gender differences in attitudes toward science in Switzerland. *Public Understanding of Science*, 13(2), 191–199. <https://doi.org/10.1177/0963662504043870>
- Russell, M. S. & T. (1986). Elementary science as a little added frill: A report of two case studies. *Science Education*, 70, 519–538.
- Sadler, P. M., Sonnert, G., Hazari, Z., & Tai, R. (2012). Stability and volatility of STEM career interest in high school: A gender study. *Science Education*, 96(3), 411–427. <https://doi.org/10.1002/sce.21007>
- Sugiono. (2012). *Metodologi Penelitian Kuantitatif Kualitatif dan R&D*.
- Tosun, T. (2000). The Beliefs of Preservice Elementary Teachers Toward Science and Science Teaching. *School Science and Mathematics*, 100(7), 374–379. <https://doi.org/10.1111/j.1949-8594.2000.tb18179.x>
- Tourney, C. P. (1992). The moral character of mad scientists: A cultural critique of science. *Science, Technology, & Human Values*, 17, 411–437.
- Wallace, J., & Loudon, W. (1992). Science teaching and teachers' knowledge: Prospects for reform of primary classroom. *Science Education*, 5(76), 507–521.
- Wyer, M., Schneider, J., Nassar-McMillan, S., & Oliver-Hoyo, M. (2010). Capturing Stereotypes: Developing a Scale to Explore US College Students' Images of Science and Scientists. *International Journal of Gender, Science and Technology*, 2(3).
- Zingg, A., & Siegrist, M. (2012). Measuring people's knowledge about vaccination: Developing a one-dimensional scale. *Vaccine*, 30(25), 3771–3777. <https://doi.org/10.1016/j.vaccine.2012.03.014>



## SEE-427

# COVID-19 Impact towards Domestic Immigrant Worker in Malaysia: Case Study in Petaling

**Nurul Asmaa Akmal binti Md Din. Awang Azman bin Awang Pawi. Rosila Bee MohdHussain.**

Department of Academy of Malay Studies, University of Malaya, Malaysia

*Corresponding author\*:s2002977@siswa.um.edu.my / awangazman@um.edu.my*

### Abstract

This research is conducted to observe the survival among domestic foreign workers in Malaysia. The objective of this research is to examine the survival of these domestic foreign workers before and during the Covid-19 pandemic. This article also analyses the strategy to overcome significant issues faced by these workers due to Covid-19. Grounded Theory is applied in this article to analyse the condition of foreign workers during and post Covid-19 pandemic. Methods that are used to gather preliminary data in this research are through observation and interview. These foreign workers always receive negative stereotypes within the community and the situation has worsened since the Covid-19 outbreak. However, these immigrants have to continue relying to any kind of available sources to sustain their life.

**Keywords:** domestic workers, immigrants, Covid-19 pandemic, Grounded Theory, life sustenance

### Introduction

The world is facing a global pandemic of dire and spreading outbreak which is caused by severe acute respiratory syndrome coronavirus 2 (SARS-CoV-2) or also known as Coronavirus 2019 (COVID-19). This illness was first identified in China and has spread globally to every part of the world in early January 2020. The Covid-19 pandemic in Malaysia is divided into three clusters. The first cluster to commence in Malaysia is the Sri Petaling Mosque cluster which caused a total of 2,766 positive cases. However, the country was unprepared at that point of time as Malaysia is in the midst of political upheaval.

The Ministry of Health (MOH) plays an important role in combating against the spread of Covid-19. According to Shah et al., (2020), among the initiative taken to contain the spread of Covid-19 is through the enforcement of stringent screening process at all entries to identify any visitors with symptoms such as fever upon arrival from other countries. Moreover, another initiative rolled out is the new additional hospitals specialised in treating Covid-19 illness. The most substantial step taken by MOH to break the chain of Covid-19 is by enforcing the Movement Control Order (MCO) on 18 March 2020. This action was executed to ensure that all citizens stay at home and practice social distancing to avoid Covid-19 from spreading within the community. The MCO enforcement has urged the whole nation to stay at home and only essential services are allowed to operate within this period.

Although MCO has contributed to the improvement of the Covid-19 pandemic situation in Malaysia, there are many parties that have been negatively affected by the enforcement. Among the parties are both legal and illegal immigrants. These immigrants are involved in various economic sectors in Malaysia such as domestic sector, agriculture and construction. Domestic work can be classified as basic work or also known as 'dirty job'. This sector is categorised as basic work due to its requirement of acquiring fundamental skills such as sweeping, cleaning, taking care of children or individual with special health needs or persons with disabilities (PWD).



the 5<sup>th</sup> ICTROPS

International Conference  
for Tropical Studies and Its Applications

Islamic Development Bank 4in1 Project  
Project Implementation Unit  
University of Mulawarman



IsDB  
البنك الإسلامي للتنمية  
Islamic Development Bank



Domestic work is not only popular among the developed nations such as United States and Korea, but it is also a booming sector in a developing country such as Malaysia. Domestic workers receive high demands from Malaysians either for companies or private residences (Hamzah & Daud, 2018). However, previous study had shown that domestic workers do not receive any recognition and appreciation from the society (Kontos, 2014). This situation is aggravated with the emergence of Covid-19 outbreak globally. Domestic workers have been adversely affected by the current pandemic crisis due to their illegal status within the country. A lot of companies are not able to operate their businesses as usual and this matter has led to the termination of foreign workers to reduce the companies' loss (MyMetro, 2020). The Government has announced the enforcement of Movement Control Order (MCO) in March 2020 and this restriction order has significantly halted most of the economic sectors. For instance, companies have to resort to employees' termination and shutting down their businesses.

The Covid-19 pandemic has equality effects towards locals and domestic workers as they need to face several life crisis pertaining to its impact. Hence, the impacts are severe towards the foreign workers community as they could not afford sustainable living due to limited job vacancies etc. Based on a report published (Mohd Syalmizi, 2021) in Kosmo Newspaper on 21 June 2021, Chief Minister, Chow Kon Yeow has stated that according to a statistic by Polis Diraja Malaysia (PDRM), a total of 19 attempted suicide cases were reported since the enforcement of Movement Control Order (MCO).

The Movement Control Order (MCO) is a paradigm effort by the government to contain the Covid-19 outbreak progressively. However, MCO has led to the closure of various sectors such as economic sector, industrialisation sector, construction sector, manufacturing sector, business sector and etc. Only essential services are allowed to operate, for instance, water, electricity, energy, communication, post and courier, transportation, irrigation system, oil and gas, fuel, lubrication, broadcasting, finance, banking, health, pharmacy, firefighter, investment, jail, airport, security, cleaning services, defense, retail and food supply.

Consequently, majority of Malaysian citizens are affected by the enforcement of MCO. Besides the locals, the impact of MCO enforcement has also hard hit the foreigners who work in Malaysia. Nevertheless, how serious does the impact of Covid-19 pandemic and Movement Control Order (MCO) towards the foreigners in Malaysia? Does this group of people use their stimulus-response mechanism to overcome the problem? Based on the issue highlighted above, researchers have observed the life sustainability of these foreign workers during pre and post Covid-19 pandemic and their stimulus-response mechanism towards the crisis.

So, this research is aimed to study the life sustainability of foreign workers before the emergence of Covid-19 outbreak and post Covid-19 pandemic. To analyse the strategy applied by the foreign domestic workers to overcome the challenges encountered during the Covid-19 pandemic.

## Methodology

Researcher has used the observation and interview method to gather data by understanding the life sustainability of foreign domestic workers. Basic theory or also known as 'Grounded Theory' is applied to analyse the data. Grounded theory is commonly used by researchers in the social science discipline.

According to Sbaraini et al (2011), Grounded Theory is focused on process or action in general: or in other words, researcher will ask "what is happening" and how people interact. This exemplifies the psychological approach which focused on the underlying meaning of people's action. The theory will be initiated with open question and researcher believes that they have prior knowledge towards the meaning which encourages respondents' action. However, researcher requires answers from the respondents in a practical manner. Sbaraini also justified that Grounded Theory consists of 7 elements, which are, openness, analysing immediately, coding

and comparing, memo-writing, theoretical sampling, theoretical saturation and production of Grounded Theory which is known as production of a substantive theory.

Chong (2015) mentioned that Grounded Theory is part of qualitative research design. Opie (2004) also outlined that Grounded Theory is part of data collection process and conduct data analysis to generate category for phenomena and situation description. Creswell (2012) also believed that Grounded Theory acts as an essential instrument to explain certain situation towards the natural phenomena.

### **Data Collection**

All data is collected through field study which is made available via observation and conducting interviews. The selection of location study is determined by the total Covid-19 cases based on the districts reported by the Ministry of Health (MOH). There are 9 districts in Selangor which are Kuala Selangor, Sabak Bernam, Klang, Hulu Langat, Petaling, Hulu Selangor, Gombak, Sepang and Kuala Langat. Comparison has been made among the total number of Covid-19 cases from all districts. Therefore, district with the highest Covid-19 cases is Petaling district which is aimed as the location study for researcher to collect data. As a result of that, the target group will be janitors who work within Petaling district. Ideally, both methods will demonstrate the daily life of foreign domestic workers holistically.

### **Location Study**

Location study is determined based on the total daily cases reported by the Ministry of Health (MOH) after the Movement Control Order 1.0 is lifted. Nonetheless, the total case of Covid-19 has surged due to various factors such as Sabah election, inter-state travel and etc. The Covid-19 cases reports are taken from 1st September 2020 to 31st August 2021. A 1 year or 12 months report has shown that Petaling district recorded the most infections with 169,220 cases. Hence, Petaling district is chosen as the location study for data collection purpose.

### **Data**

The aspect that should be reviewed in the research scope will be monitored through extensive observation during the field study. A total of 30 respondents were interviewed to obtain detailed information for the research. Majority of the foreign workers were uncooperative during the interview due to the language barriers (unable to speak fluently in Malay or English) and concern of their own safety.

The secondary data applied in this study consist of reliable and published data. This data set is used as supporting data to close the loopholes in the study. The data set derives from newspapers, journals and reports published by authorities such as academician, journalists and etc.

### **Sampling Frame**

The approach used in this study is through random sampling method. Observation has been made within targeted areas where the foreign workers reside in Klang Valley, which is located in Petaling district. The district is chosen due to the highest number of Covid-19 cases reported within the span of 12 months.



the 5<sup>th</sup> ICTROPS

International Conference  
for Tropical Studies and Its Applications

Islamic Development Bank 4in1 Project  
Project Implementation Unit  
University of Mulawarman



IsDB  
البنك الإسلامي للتنمية  
Islamic Development Bank



**Table 1.** Situation faced by Foreign Workers Before and After Pandemic

Aspect	Before Pandemic	During Pandemic
Economy	Uncertain working opportunities	Less working opportunities/ Novacancies due to MCO
	Unfixed salary	Termination of employment
	Must acquire permit applied by employer	Workers who travel to their home country are denied entry to Malaysia due to the closure of borders
	Earn a lower salary rate paid by employers	Most employers prefer local workers compared to foreign workers
	Offer services via booking through third party/mobile phone	Stringent working procedures
	No health requirements	Frequent swab test (RTK.PCR) is required
	Compulsory to wear uniforms/ attire according to the requirements set by employers	Compulsory to wear Personal Protective Equipment (PPE) to avoid from Covid-19 infection (facemask, gloves) Difficulty to obtain vaccination appointment (later list)
	Able to work from anywhere but paid with low salary	Always at risk due to working
Social	Live in uncomfortable workers' accommodations	Accommodation which requires segregation Accommodation to provide room for social distancing (higher cost)
	Use daily public transport to move from one place to another	Restrict movement due to 50% capacity for public transport announced by the government
	Being oppressed by employers (migrant workers are not paid for their services)	Being deceived by certain parties regarding their permit issue
Psychology	Terrified of being captured due to failure to provide working permit	Feeling anxious (Covid-19, afraid of being captured by the authorities)
	Mentally depressed due to being unfairly treated by employer	Mentally depressed due to movement restriction during MCO
	Death due to workplace incidents or suicide	Additional death cases due to Covid-19 and suicide

## Results and Discussion

From the study, it is observed that foreign workers are facing a hard time working in Malaysia. Based on the interview conducted, there are a lot of challenges faced by the foreign workers in various aspects. The significant aspects which are viewed in this study are divided into three, which are, economical, social and psychological aspects.

**Table 2.** Stimulus-response of Foreign Workers during Covid-19 Pandemic

Challenges during Pandemic	Stimulus-response Mechanism
Less working opportunities/ No vacancies due to MCO	Travel back to home country and seek new job Apply for assistance from employment agency in Malaysia but they are required to switch their working field. For instance, the individual works as a building janitor before pandemic but he needs to switch his job to become a dish cleaner or security guard during pandemic.
Termination of employment	
Workers who travel to their home country are denied entry to Malaysia due to the closure of borders	
Most employers prefer local workers compared to foreign workers	
Stringent working procedures	Receive vaccination from the Government of Malaysia
Frequent swab test (RTK.PCR) is required	Employment agency will provide the swab test or offer jobs that do not require for swab test to be conducted
Compulsory to wear Personal Protective Equipment (PPE) to avoid from Covid-19 infection (facemask, gloves)	Wear the basic protection such as apron, facemask and gloves.
Difficulty to obtain vaccination appointment (later list)	-
Always at risk due to working	Find new jobs which are less risky and practice social distancing (if necessary)
Accommodation which requires segregation	No options available and need to stay at the accommodation (hostel) provided by their employer Find a house to rent with affordable price but do not have many tenants Find employers who provide hostels
Accommodation to provide room for social distancing (higher cost)	
Restrict movement due to 50% capacity for public transport announced by the government	
Being deceived by certain parties regarding their permit issue	-
Feeling anxious (Covid-19, afraid of being captured by the authorities)	Always bring personal document and look for employment agent who could provide assistance if captured by the authorities.
Mentally depressed due to movement restriction during MCO	-
Additional death cases due to Covid-19 and suicide	Assistance from NGO and the society to avoid the foreign workers from initiating any form of action that is harmful to themselves.

Based on the interview conducted, the foreign workers are forced to seek new working opportunities which do not require stringent procedures and rules. However, they are being paid lesser compared to their initial jobs. During the Movement Control Order (MCO), foreign workers stated that they rely on public assistance such as NGO or their own neighborhood. There are workers who receive assistance such as food from their employers. Food assistance funded by the local society also provide ease to the foreign workers' burden.

For the vaccination issue, foreign workers have no choice other than waiting for the vaccine provided by their employers or the government. Even though the workers need to queue for a longer time, they do not have any options but to follow as Covid-19 vaccine is not available to be purchased anywhere. There are a few workers



International Conference  
for Tropical Studies and Its Applications

Islamic Development Bank 4in1 Project  
Project Implementation Unit  
University of Mulawarman



IsDB  
البنك الإسلامي للتنمية  
Islamic Development Bank



who opt for new jobs which do not require them to be vaccinated such as labour jobs regardless being paid with a low salary. This matter has taken a toll on foreign workers, nevertheless, it is the only way to ensure their survival during this pandemic.

In terms of psychology, these workers are working hard to survive and earn money for their family abroad. Subsequently, they are feeling depressed, worried and anxious regarding the pandemic issue but continue to brace the situation as they are left with no choice. In addition, all borders are strictly secured by the authorities which deny the workers' opportunity to travel to their home country or come back to Malaysia.

### Conclusions

The Government of Malaysia has provided financial assistance, employment opportunity and vaccination to all affected local citizens. Therefore, majority of employers are inclined towards recruiting local workers due to their health history and easier to locate their whereabouts. Local workers can be easily traced because they are able to provide valid information compared to the migrant workers who do not have a valid information regarding their accommodation and health history. Researcher can review the strategy used by migrant workers to survive the Covid-19 crisis based on the economic, social and psychological aspects.

### ACKNOWLEDGEMENT

Thank you to all foreign janitors in Petaling district who have been cooperative during the interview session to complete this research. We hope that this study will be expanded within the domestic sector especially in cleaning services.

### REFERENCES

- Creswell, J. W. (2012). Educational research: Planning, conducting, and evaluating quantitative and qualitative research (4th ed.). Upper Saddle River, NJ: Pearson.
- Chong, C.-H., & Yeo, K.-J. (2015). An Overview of Grounded Theory Design in Educational Research. *Asian Social Science*, 11(12).doi:10.5539/ass.v11n12p258
- Hamid, M. S. (2021, June 21). 53 kes bunuh diri dalam lima bulan di Pulau Pinang. *Suara Kontemporari Kosmo*, 1–6. <https://www.kosmo.com.my/2021/06/21/53-kes-bunuh-diri-dalam-lima-bulan-di-pulau-pinang/>
- Hamzah, I. S., & Daud, S. (2018). Implikasi Kemasukan Pekerja Asing Di Malaysia: Suatu Tinjauan Awal. *Sains Insani*, 1(1), 69–77. <https://doi.org/10.33102/sainsinsani.vol1no1.11>
- Hashim, J. H., Adman, M. A., Hashim, Z., Mohd Radi, M. F., & Kwan, S. C. (2021). COVID-19 Epidemic in Malaysia: Epidemic Progression, Challenges, and Response. *Frontiers in Public Health*, 9(May), 1–19. <https://doi.org/10.3389/fpubh.2021.560592>
- Opie, C. (2004). Research Approaches. In C. Opie (Ed.), *Doing educational research* pp. 73-94). London: Sage.
- Sbaraini, A., Carter, S. M., Evans, R., & Blinkhorn, A. (2011). How to do a grounded theory study: A worked example of a study of dental practices. *BMC Medical Research Methodology*, 11. <https://doi.org/10.1186/1471-2288-11-128>
- Shah, A. U. M., Safri, S. N. A., Thevadas, R., Noordin, N. K., Rahman, A. A., Sekawi, Z., Ideris, A., & Sultan,



the 5<sup>th</sup> **ICTROPS**

International Conference  
for Tropical Studies and Its Applications

Islamic Development Bank 4in1 Project  
Project Implementation Unit  
University of Mulawarman



IsDB  
البنك الإسلامي للتنمية  
Islamic Development Bank



M. T. H. (2020). COVID-19 outbreak in Malaysia: Actions taken by the Malaysian government. *International Journal of Infectious Diseases*, 97, 108–116. <https://doi.org/10.1016/j.ijid.2020.05.093>

30,000 Hilang kerja, 10,000 dicutikan. (2020, June). *MyMetro*. Retrieved September 20, 2021, from <https://www.hmetro.com.my/utama/2020/06/584580/30000-hilang-kerja-10000-dicutikan>.

## SEE-430

# Exploring Science and Engineering Practices in Indonesian Physics Textbook about Heat and Temperature

Septyani Triwulandari <sup>\*1</sup>, Roro Dinda Althaf F Z Azizah.<sup>1</sup>, Muliati Syam<sup>1</sup>, Pramudya Dwi Aristya Putra<sup>2</sup>, Nurul Fitriyah Sulaeman<sup>1</sup>

<sup>1</sup>Physics Education Program, Mulawarman University

<sup>2</sup>Science Education Program, University of Jember

Corresponding Author\*: [septyanitw14@gmail.com](mailto:septyanitw14@gmail.com)

## Abstract

During the distance learning, science lesson needs to adapt to the online class. This adaptation drives the need for student's independence of learning. It has been argued that students' understanding of science ideas and concepts is based on their engagement in science and engineering practices. However, research studying science and engineering practices engaging in high school textbooks in Indonesia is particularly limited. The present study investigates the level at which science and engineering practices engage in Indonesian high school Physics textbooks about heat and temperature. The analysis was carried out on a total of five books that are widely used in the school. Reports and activities were analyzed using content analysis through an assessment rubric called "Science and Engineering Practices Analytic Rubric" (SEPAR) by two ratters. The results analysis shows that the students could use science and engineering practices, but these school textbooks direct it. The books have not facilitated the opportunities to create and develop science and engineering practices at these points. The results mean that these school textbooks are at a low level because there is only one book at a high level. Therefore, there is a need to engage more clearly the science engineering practices in physics textbooks.

**Keywords:** Science and engineering practices, School physics textbooks, High school

## Introduction

Physics learning in schools is carried out by following the steps of the contextual and scientific methods. Using a scientific approach, can help students think critically, understand nature, apply science in real-life practice, and influence students' skills and motivation in learning (Nurul, Azkia, & Fatni, 2020). So that teaching materials are needed in accordance with these aspects. The textbook is the main guide in the teaching and learning process for students (Rofidah, Junus, & Hakim, 2020). School textbooks directly affect student learning where students interact with textbooks and indirectly influence student learning through their effects on teachers during the teaching process (Papakonstantinou & Skoumios, 2021). Therefore, textbooks are very important in learning physics and other learning.

In learning physics, student activity is essential (Alifa, Azzahroh, & Pangestu, 2018). Student engagement was very high during STEM activities, including engagement associated with the topic of the STEM activity, the design activity itself, and students' relationships with their peers (Sulaeman et al., 2021). Thus, this is very much in line with the application of STEM. STEM is effective learning because it combines knowledge, mathematics, technology, and techniques so that students can apply and practice the basic content of STEM in the situations they face in life (Almuharomah, Mayasari, & Kurniadi, 2019). 21st-century skills are also needed this day because it is include learning skills, creating innovation, mastering technology and media, and being able to solve problems creatively. So that the application of STEM in books can support learning because it includes 21st-century skills (Nurul, Asrizal, & Fatni, 2020).





the 5<sup>th</sup> ICTROPS

International Conference  
for Tropical Studies and Its Applications

Islamic Development Bank 4in1 Project  
Project Implementation Unit  
University of Mulawarman



IsDB  
البنك الإسلامي للتنمية  
Islamic Development Bank



Temperature and heat are physical materials that have many applications in life. Temperature and heat contain material about the energy contained in an object, so there is a transfer in its use (Sofianto & Irawati, 2020). In this material, there are science and engineering practices that can be taught to students. In its application, students can practice science and engineering on this material, by making a simple vaccine temperature box (Siverling et al., 2016). However, in textbooks, the practice of science and engineering still does not involve students' skills. So in this case, science and engineering (STEM) practical activities to be applied to textbooks are needed, especially on temperature and heat material.

Although many books have been researched, findings of STEM components in books are still rare. This can be seen from the research on critical thinking skills of students of class XI science in public schools in Banjarmasin the, test results show that students' critical thinking skills are still not trained. These results can be seen from the indicators of skills in formulating questions and answers which are categorized as low, indicators of analyzing and reporting experimental results are categorized as sufficient, drawing conclusions, determining actions and formulating alternative solutions are classified as low (Hartini, Mariani, Misbah & Sulaeman, 2020). Therefore, STEM textbook is needed to improve skills in these aspects where the STEM component in the textbook can be used as a support. Researchers want to analyze the STEM components in several physics textbooks, especially on the material of temperature and heat. So, from this study, the high and low level of the STEM component in the textbook can be seen.

## Methodology

This research on heat and temperature textbooks were analyzed using content analysis. The analysis focuses on five high school physics textbooks for XI class which are widely used in schools. This analysis aims to identify science and engineering practices in school textbooks, where students are involved in science and engineering practices in selected school textbooks to be analyzed. The research process is divided into three phases. The first phase is to collect five high school physics textbooks. Then, examine the book's contents on the temperature and heat material chapter using the SEPAR framework. After analyzing, data is processed and a conclusion is drawn.

The instrument used in this research is the Analytical Rubric of Science and Engineering Practice (SEPAR), to evaluates the level at which students engage science and engineering practices in school textbooks (Papakonstantinou & Skoumios, 2021). This framework is a rubric consisting of 4 levels with eight aspects. The unit analysis involved the levels according to the extent of science and engineering practice in school textbooks. When school textbooks do not allow student to engage in science and engineering practices, it is classified at level 0. The other levels (1, 2, and 3) show school textbooks opportunities for students to improve their abilities in practising science and engineering. The unit analysis (classification level) relates to the level of involvement on each of the eight aspects based on the SEPAR rubric.

Two researchers from science education carried out content analysis. The analysis results carried out by these researchers were then calculated by descriptive statistical analysis, by calculating the percentage of each aspect of the assessment contained in the SEPAR rubric (Arisya & Holiwarni, 2021). The equation used is:

$$R = \frac{f}{n} \times 100\% \quad (1)$$

R = score percentage

f = amount of aspect value

n = amount of textbooks

The average is calculated using the inter rate agreement (Sucahyanti et al., 2018). The equation used is as follows:

$$\text{inter - rater agreement} = \frac{\text{Number of cases with same score from two rater}}{\text{Number of cases}} \times 100 \quad (2)$$

## Results and Discussion

The results of the data analysis identified the level of practice involved in the content about temperature and heat included in the High School Physics book.

**Table 1.** Identification of aspects

Aspek	Book 1	Book 2	Book 3	Book 4	Book 5
Asking questions and defining problems	1	1	1	1	1
Developing and using models	1	2	3	0	2
Planning and carrying out investigations	1	1	3	1	1
Analyzing and interpreting data	1	2	2	0	2
Using mathematics and computational thinking	2	1	2	2	2
Constructing explanations and designing solution	2	2	2	0	2
Engaging in argument from evidence	1	1	1	0	1
Obtaining evaluating and communicating information	3	3	3	1	1



the 5<sup>th</sup> ICTROPS

International Conference  
for Tropical Studies and Its Applications

Islamic Development Bank 4in1 Project  
Project Implementation Unit  
University of Mulawarman



IsDB  
البنك الإسلامي للتنمية  
Islamic Development Bank

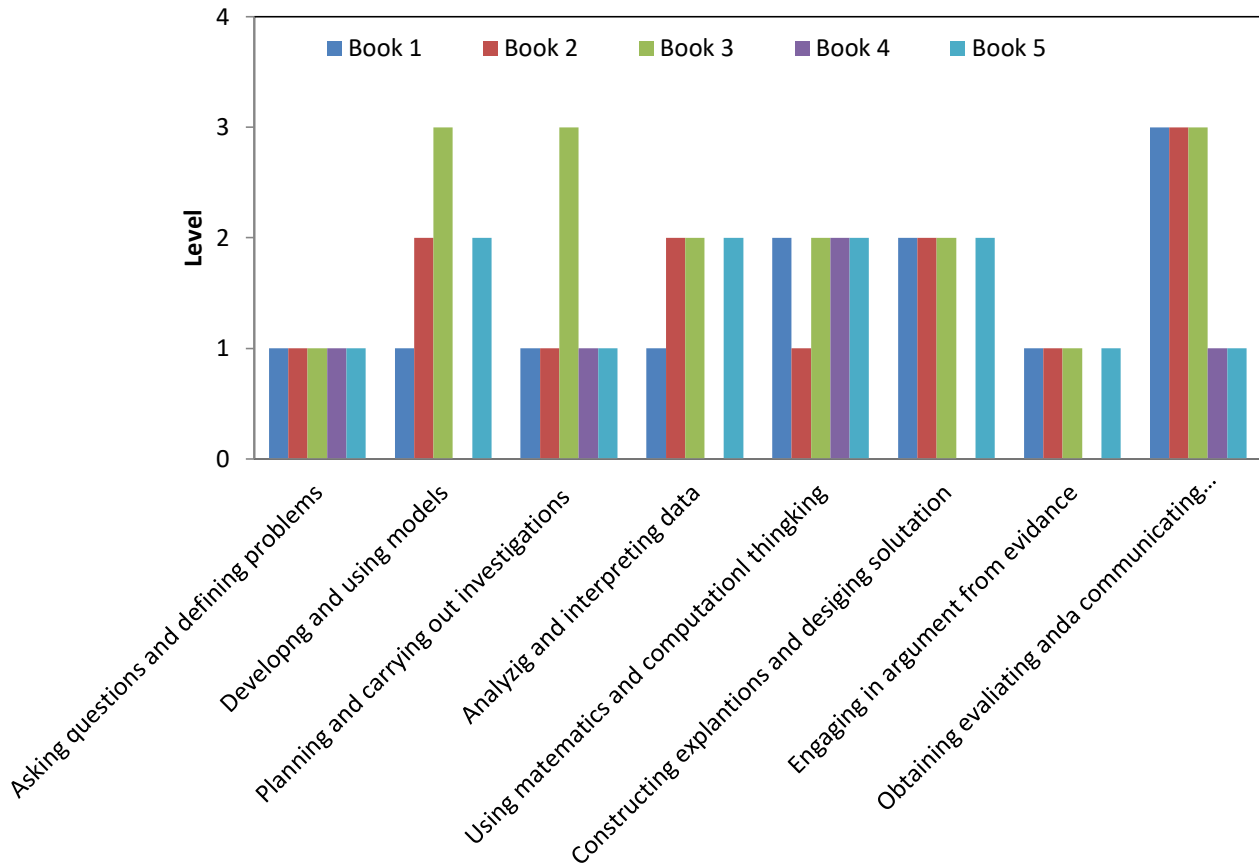

**Figure 1.** Result by NGSS Aspects

### Asking questions and defining problems

There is a practice of asking questions and defining problems in the five books that were analyzed. There is the opportunity for students to ask, but it is not explained whether the questions to be discussed must be scientific or non-scientific. This test book also provides opportunities for students to define problems that can be solved (using previously acquired knowledge) through the development of an object, tool, process or system, and determine criteria related to the time or cost of solving the problem to be determined. The text book also provides opportunities for students to define problems that can be solved (using previously acquired knowledge) through the development of an object, tool, process or system, and determine criteria related to the time or cost of solving the problem. However, it has been underlined that when students are given the opportunity to ask questions or define problems, their active involvement in the research process can be increased, as shown by the data.

### Developing and using models

In this aspect, regarding to the practice of developing and using models, these several textbooks have provided opportunities for students to use models that aim to describe natural phenomena. The students were also asked to predict and explain based on the phenomena that were obtained. However, one of the books, namely book 4, it does not provide opportunities for students to develop their abilities by making models. Therefore, a textbook that gives students the opportunity to develop a model is needed. It can increase students interest in the lesson. The research data also shows that the model development by students makes their participation in the learning process.

### **Planning and carrying out investigation**

In the practice of designing and conducting investigations, textbooks provide an opportunity to design or conduct an investigation for data collection. However, in this case, student engagement is guided by the textbook. But in one of the books, namely book 3, students are given the opportunity to make decisions about experimental and control variables.

### **Analysis and interpreting thinking**

In the practice of analyzing and interpreting data, the three analyzed textbooks provide opportunities for students to work with data to organize or group the data in tables or graphics. This opportunity can support the students in drawing inferences from data through recognizing patterns and in nature relation. But in the two books that have been analyzed, one of them provides opportunities for students to work with data without drawing conclusions from pattern recognition and in nature relation. And in other textbooks, it only gives students the opportunity to record data but not to analyze it.

### **Using mathematics and computational thinking**

The practice of using mathematics and computational thinking, the four textbooks that were analyzed, provides an opportunity to use mathematical skills or concepts and connected computational thinking to answer scientific questions. This is shown in every activity in the book, which aims to develop students' abilities to use mathematics and computational thinking. However, one book it gives students the opportunity to use mathematical skills or concepts of computational thinking without being connected to answer questions.

### **Constructing explanations and designing solution**

The practise of constructing explanations and designing solutions can be found in 4 textbooks. Some activities give students the opportunity to build scientific explanations by encouraging them to use appropriate evidence to support explanations or design solutions for problems by applying scientific ideas, although without generating and comparing multiple solutions to the problem. This is shown in activities such as discussions in one of the textbooks. But another book shows a low level where students are not given the opportunity to construct scientific explanations (related to how or why a phenomenon) or design a solution. The practise of engaging in evidence-based arguments is at a low level. In 4 textbooks, students are only given the opportunity to engage in arguments by encouraging them to support claims with evidence or reasons. However, their discourse is guided by the textbooks. And one of the other textbooks did not give students the opportunity to engage in self-guided arguments where they could be assessed by themselves and their classmates.

### **Engaging in argument form evidence**

The practise of engaging in evidence-based arguments is at a low level. In 4 textbooks students are only given the opportunity to engage in arguments by encouraging them to support claims with evidence or reasons. However, their discourse is guided by the textbook. And one of the other textbooks did not give students the opportunity to engage in self-guided arguments so that they could be assessed by themselves and their classmates.

### **Obtaining evaluating and communicating informing**

In 3 textbooks, students are given the opportunity to read and use texts to obtain scientific information. They are encouraged to distinguish or combine the information from many texts by examining the strength of the information and its sources. Two books provide the access to scientific information from "additional" texts. At the same time, while they are not asked to find this information or to compare or combine information from various texts by examining the strength of this information and its sources.



the 5<sup>th</sup> ICTROPS

International Conference  
for Tropical Studies and Its Applications

Islamic Development Bank 4in1 Project  
Project Implementation Unit  
University of Mulawarman



IsDB  
البنك الإسلامي للتنمية  
Islamic Development Bank



## Conclusions

Based on this research, the purpose was to explore the practise of science and engineering involved in Indonesian textbooks with the temperature and heat material contained in high school physics textbooks. Base on the results of the analysis, it was found that these textbooks have not facilitated the opportunity to design and develop the practice of science and engineering in each activity. So the results show that this school textbook is at a low level. Because there is only 1 textbook that is at a high level, it can be said that the textbook facilitates activities in designing and developing science and engineering practice. Therefore, textbooks that involve more science and engineering practice are needed.

## REFERENCES

- Alifa, D. M., Azzahroh, F., & Pangestu, I. R. (2018). Penerapan Metode STEM (*Science, Technology, Engineering, Mathematict*) Berbasis Proyek Untuk Meningkatkan Kreativitas Siswa SMA Kelas XI pada Materi Gas Ideal. *Seminar Nasional Pendidikan Sains*. 88–109.
- Almuharomah, F. A., Mayasari, T., & Kurniadi, E. (2019). Pengembangan Modul Fisika STEM Terintegrasi Kearifan Lokal “ Beduk ” untuk Meningkatkan Kemampuan Berpikir Kreatif Siswa SMP. *Berkala Ilmiah Pendidikan Fisika*, 7(1), 1–10. <https://doi.org/10.20527/bipf.v7i1.5630>
- Arisya, F., Haryati, S., & Holiwarni, B. (2021). Pengembangan Modul Berbasis STEM (*Science, Technology, Engineering, And Mathematict*) Pada Materi Sifat Koligatif Larutan. *Jurnal Pendidikan Kimia Universitas Riau*, 6(1), 37–44.
- Firmonia, N. A., Asrizal., & Mufit, F. (2020). Pengembangan Bahan Ajar Fisika Materi Fluida Terintegrasi Literasi Baru dan Bencana Untuk Meningkatkan Hasil Belajar Siswa Kelas XI. *Pillae of Pembelajaran Fisika*. 13(1), 9–16.
- Sofianto, E. W. N., & Irawati, R. K. (2020). Upaya meremediasi konsep fisika pada materi suhu dan kalor. *Southeast Asian Journal Of Islamic Education*. 02(02), 109–124.
- Papakonstantinou, M., & Skoumios, M. (2021). Science And Engineering Practices In The Content Of Greek Middle School Physics Text Books About Forces Ans Motion. *Journal of Technology and Science Education* 11(2), 457–473.
- Rofidah, R., Junus, M., & Hakim, A. (2020). Analisis Perbandingan Buku Teks Fisika Siswa SMA Kelas XI Antara Buku Sekolah Elektronik ( BSE ) dan Buku Non BSE Ditinjau Pada Komponen Kelayakan Isi , Penyajian Materi Ajar, Penyajian Pembelajaran, dan Kebahasaan. *Jurnal Literasi Pendidikan Fisika* ,1(2), 97–104.
- Sucahyanti, K. N., Adnyana, I. P. B., Santiasa, I. M. P. A. (2018). Pengembangan Instrumen Asesmen *Mind Mapping* Untuk Menilai Pemahaman Konsep Biologi. *Jurnal Pendidikan Biologi Undiksha*, 5(2).
- Hartini, S., Mariani, I., Misbah & Sulaeman, N. F. (2020). Developing of students worksheets through STEM approach to train critical thinking skills. *Journal of Physics: Conference Series*. <https://doi.org/10.1088/1742-6596/1567/4/042029>
- Sulaeman, N. F., Putra, P. D.A., Mineta, I., Hakamada , H., Takahashi, M., Ide, Y., & Kumano, Y. (2021). Exploring Student Engagement in STEM Education through the Engineering Design Process. *Jurnal Penelitian dan Pembelajaran IPA*, 7(1), 1–16. <https://doi.org/10.30870/jppi.v7i1.10455>
- Siverling, E., Rozowa, P., Carlovsky, J., Glancy, A., Douglas, K., & Moore, T. (2016). EngrTEAMS Engineering to Transform the Education of Analysis, Measurement, and Science in a Team-Based Targeted Mathematics-Science Partnership. *University of Minnesota And Purdue University Research Foundation*.



the 5<sup>th</sup> ICTROPS

International Conference  
for Tropical Studies and Its Applications

Islamic Development Bank 4in1 Project  
Project Implementation Unit  
University of Mulawarman



IsDB  
البنك الإسلامي للتنمية  
Islamic Development Bank



SEE-437

## Power Generation Potential Based On Wind Speed Variations In Wind Power Plant Prototypes

Restu Mukti Utomo<sup>1</sup>, Muhammad Rifaldi<sup>2</sup>, Agung Tandiminanga<sup>3</sup>, Siska Mayra Andini<sup>4</sup>, Nur Rani Alham<sup>5</sup>

Department of Electrical Engineering, Mulawarman University, Indonesia

Corresponding Author: *agungtan07@gmail.com*

### Abstract

Future energy is a term for developing renewable energy (RE) potential as a solution or alternative to fulfill the needs of increasing energy consumption. Conventional energy production depends on dwindling fossil energy sources, its renewal takes hundreds of millions of years, and its side effect can increase global warming. One renewable energy source that is environmentally friendly and available in nature with unlimited quantities is wind. Indonesia is an archipelago country with a tropical climate that can use wind energy as a wind power plant (PLTB), either on the coast or hills. A wind power plant (PLTB) is a generator that converts wind energy into electrical energy by using turbines as movers and generators as power generators. This paper aims to determine the wind energy potential for electricity generation based on wind variations. Data collection in this study uses a small-scale PLTB prototype built by design and then measured using a multimeter and anemometer. The wind turbines used for generating electricity are four blades with a length of 45 cm and a breadth of 7 cm. The tool used as a generator is a DC motor with a capacity of 12 volts. Based on the field testing results, it found that when the highest wind speed of 3,5 m/s, the DC motor produced a current of 0,011004 Amperes and a voltage of 0,426563 Volts and at the lowest wind speed of 1,9 m/s, the DC motor produced a current of 0,005961 Amperes and a voltage of 0,231563 Volts. It can be concluded that the wind speed, type, and size of the blades and the specification of the generator greatly influence electric power generation.

**Keywords:** Wind, Renewable Energy, PLTB, Wind Turbine.

### Introduction

The increase of energy consumption in a country is one of the impacts of the growth of community and technology that continues to develop rapidly. Shiosansi stated that one of the characteristics of modern society depends on fossil fuel and nuclear to the provision of infrastructure operation to obtain the production of necessities and other crucial human services [1]. The needs for large energy and the dependence on fossil energy sources make the availability of fossil energy decreasing and are expected to run out [2]. Currently, much renewable energy is developed as a source of alternative energy to fulfill the needs of conventional energy. Renewable energy has advantages, such as being environmentally friendly, relatively easy to obtain, easy to renew naturally or by human engineering [3]. One of the renewable energy sources that can be used as alternative energy is wind energy. The potential of wind energy in Indonesia can reach 9.3 GW and the total capacity installed is approximately 0.5 MW [6]. In some areas in Indonesia, a large amount of potential wind can be used to build a wind power plant (PLTB) and save the use of conventional fuel. The electrical energy that can be generated by PLTB depends on the wind speed [7]. PLTB is a generator whose operation uses wind energy as driving energy to generate electrical energy. This generator can convert wind energy into electrical energy using a wind turbine that will drive the generator. Prototype of PLTB can be built in areas with sources of wind energy at a stable speed, for instance, the coast [9]. Indonesia has the potential of sea wind energy with an average speed of 3.4 - 4.5 m/s, which requires further study regarding the utilization of sea wind in

various regions. There are many advantages to build a PLTB prototype with a distance of approximately 10 meters on the coast, including the location factor that has many wind energies, a factor of stable wind speed, a land factor that does not disturb the community mobility, as well as reducing wind park effect on wind turbines.

Many studies about this topic have been conducted to increase the performance of PLTB, for example, Muhammad Iqbal and R M Sisdarmanto Adinandra studied making a 100-watt wind power system, and the wind turbine prototype design used was 0.38 meters in diameter. The results of the study show that the highest efficiency value of the wind turbine was 6.86% at a wind speed of 6 m/s [10]. Sunardi and Zeazelia Erwinda Sorometa also conducted a study regarding the design of the wind power plant prototype in the tropics for agricultural irrigation, and the turbine prototype design was a vertical axis wind turbine (VAWT). The results of the test show that the highest value of voltage was 6.16 V and the highest current was 0.51 A at a wind speed of 3.4 m/s [11].

Based on the explanation above, a study regarding the potential of electricity generation using the PLTB prototype requires to conduct. Data collection of potential power generation was conducted by measuring the voltage and current value generated by the generator based on the variations in wind speed. The design of the prototype consisted of the wind turbine blade with a diameter of 1 meter and a 12 volt DC motor as a generator. The voltage and current values were measured using a digital multimeter, while the wind speed value was measured using an anemometer.

## Methodology

The working principle of the PLTB prototype was by using wind energy to produce electrical energy. Wind energy will twist the turbine so that it generates rotation in the turbine shaft. The wind turbine will make the generator works and generates electrical energy. The prototype system was designed using 4 wind turbine blades with 45 cm length and 7 cm width and 12 V DC motor as a generator. A multimeter was used to measure the voltage and current values generated by the DC motor, while an anemometer was used to measure wind speed with m/s unit. The load used in this study was Light Emitting Diode (LED). The configuration of the wind power plant prototype design system (PLTB) can be seen in Figure 1.

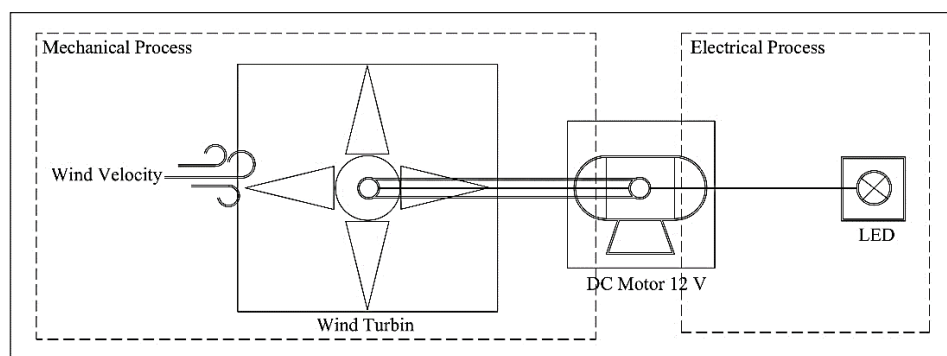

**Figure 1.** PLTB prototype system configuration

The configuration of the testing system for the design of the wind power plant (PLTB) prototype in this study is shown in Figure 2.

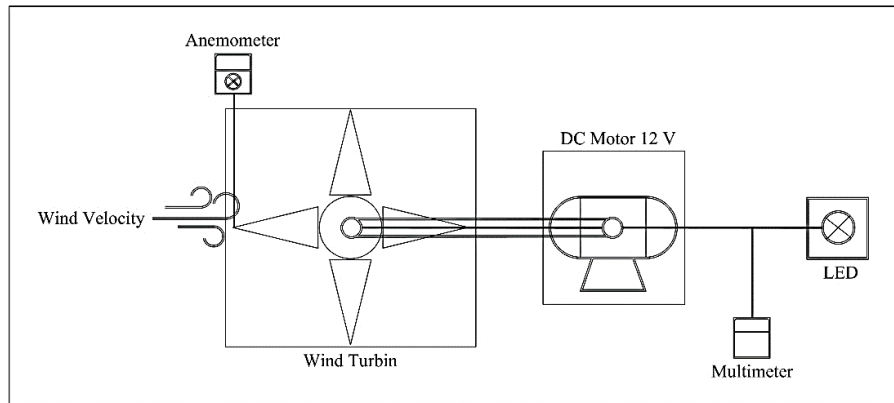

**Figure 2.** PLTB prototype system testing configuration

The measurements of this prototype is shown in Figure 3 below

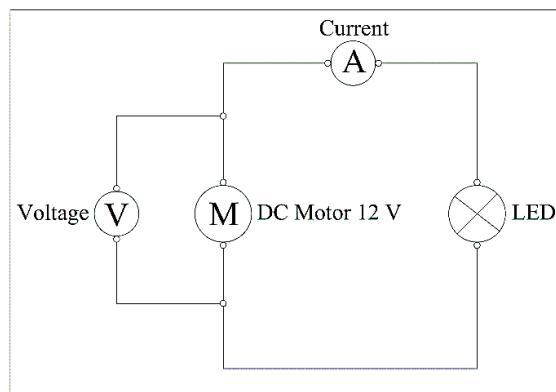

**Figure 3.** The Circuit of Current and Voltage Measurement

The main component used in this study is shown in table 1.

**Table 1.** Specification for the components of the proposed system

No	Component	Quantity	Specification
1	Digital Anemometer	1	-
2	Digital multimeter	1	-
3	Pipe 0,5 inch	1	Length = 40 cm
4	Pipe 6 inch	1	Length = 40 cm
5	Pipe ¾ inch	1	Length = 70 cm
6	DC Motor	1	12 Volt DC
7	Bolt M22	1	D = 22 mm
8	Iron clamp	1	2 Inch
9	Red LED	1	0,036 Watt
10	Jumper cable	Sufficiently	-
11	Bearing	1	D = 2 cm
12	Reducing Socket	1	¾ Inch – ½ Inch
13	Clipboard	Sufficiently	-

To determine the potential for generating electrical power generated by a wind turbine rotation, theoretically



can use the following equation (1).

$$P_m = \frac{1}{2} \rho A v^3 C_p(1) \quad (1)$$

We are given the blade length with  $l = 1$  m. Inserting the value for blade length as the radius of the swept area into equation (2), we have :

$$A = \pi r^2 \quad (2)$$

$$A = 3,14 \times (0,5)^2$$

$$A = 0,785 \text{ m}^2$$

**Table 2.** Calculation of The Theoretical Electric Power Potential in PLTB Prototype

No	Wind Speed (m/s)	Theoretical Power (Watt)
1	3,2	9,34
2	3,5	12,22
3	2,7	5,61
4	2,5	4,46
5	3,3	10,25
6	2,1	2,64
7	2	2,28
8	2,3	3,47
9	1,9	1,96
10	2,3	3,47

## Results and Discussion

The test is carried out by using a digital anemometer based on variations in wind speed different sizes, and diameters of the wind turbine. Then the data collection process has variations and comparisons of various wind speeds. The wind speed obtained in the process test ranges from 1,9 m/s – 3,5 m/s. A digital multimeter measures the current and voltage values to get real power data generated by the DC motor. The data from the result of testing the PLTB prototype in this study are shown in table 3. The data was obtained based on the testing time and wind speed so that the voltage and current were obtained

**Table 3.** Output Parameters of The Wind Power Based on Wind Speed

No	Time	Wind Speed (m/s)	Voltage (V)	Current (A)
1	01-08-2021	3,2	0,3926	0,0100
2	02-08-2021	3,5	0,426563	0,010981
3	03-08-2021	2,7	0,3491	0,0094
4	04-08-2021	2,5	0,3047	0,0089
5	05-08-2021	3,3	0,4192	0,0104
6	06-08-2021	2,1	0,2659	0,0078
7	07-08-2021	2	0,2438	0,0073
8	08-08-2021	2,3	0,2803	0,0083
9	09-08-2021	1,9	0,231563	0,005961
10	10-08-2021	2,3	0,2806	0,0085

Table 3 shows the result of current and voltage measurements based on wind speed, and it shows that the highest wind speed occurred on 02-08-2021 with a value of 3,5 m/s and produced a voltage of 0,426563 V and a current of 0,010981 A. The lowest wind speed occurred on 09-08-2021 with a value of 1,9 m/s and had a voltage of 0,231563 V and a current of 0,005961 A.

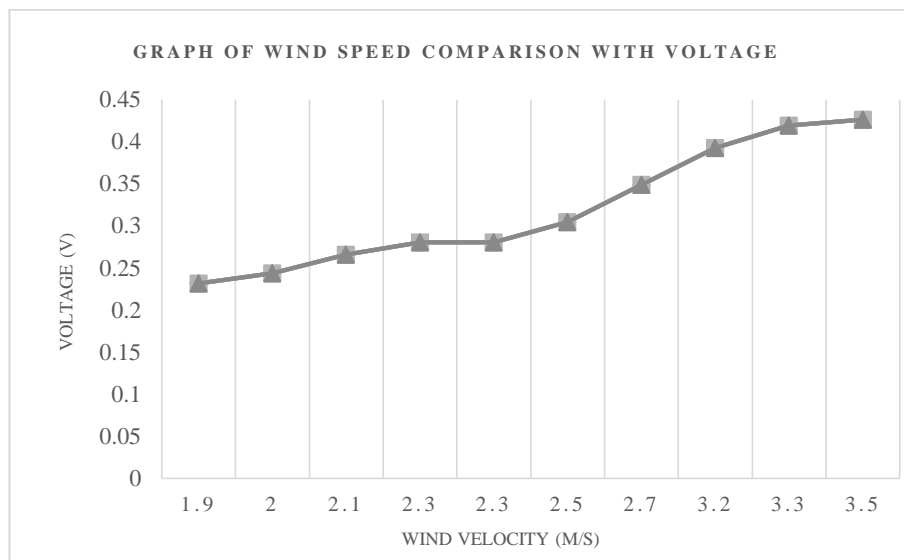

**Figure 3.** The curve of line voltage vs wind speed

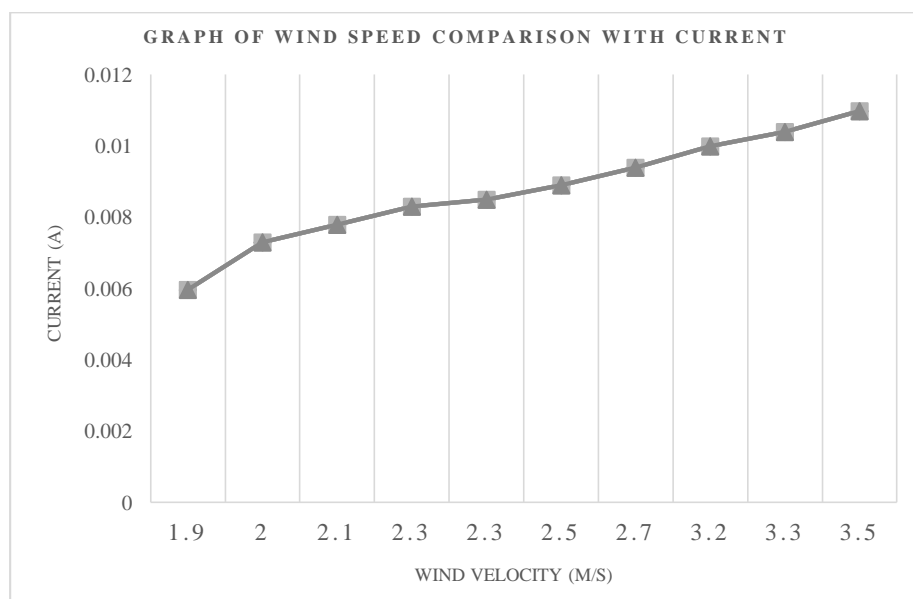

**Figure 4.** The curve of line current vs wind speed

Based on Fig. 3 and Fig. 4, the graphs show that each variation in wind speed has affected the output of the DC motor or generator. The higher the speed received by the wind turbine, the faster the rotation of the generator, so that the voltage and current output from the generator is greater. It shows that the wind speed is directly proportional to the resulting voltage and current. To obtain the total power output at the generator, we can use the power formula between current and voltage. The result of the total output power on a DC motor or generator are presented in Table 4.

**Table 4.** The Total Output Power of Generator Based on Wind Speed

No	Time(WITA)	Wind Speed(m/s)	Power(watt)	LED Condition
1	01-08-2021	3,2	0,003926	OFF
2	02-08-2021	3,5	0,004684	OFF
3	03-08-2021	2,7	0,003282	OFF
4	04-08-2021	2,5	0,002712	OFF
5	05-08-2021	3,3	0,004360	OFF
6	06-08-2021	2,1	0,002074	OFF
7	07-08-2021	2	0,00178	OFF
8	08-08-2021	2,3	0,002326	OFF
9	09-08-2021	1,9	0,00138	OFF
10	10-08-2021	2,3	0,002385	OFF

In Table 4 can be seen that up to the highest wind speed at a speed of 3,5 m/s, the potential energy obtained has not been able to occur for the LED load. That is because the current and voltage are relatively small. That happens because the rotation of the wind turbine is not optimal.

Comparison between the power generated by the generator based on direct testing with power theoretically aims to see the differences that occur in the calculation of equation (1) which has been calculated in Table 3. It is calculated based on the cross-sectional area of the wind turbine with ideal conditions without considering other factors that can disrupt the stability of the results generator output to the wind turbine. The comparison is shown in Table 5 below, with the wind speed is sorted from the lowest to the highest wind speed.

**Table 5.** Total Power Produced by Generator and Theoretical Power

No	Wind Speed (m/s)	Total Power (watt)	Theoretical Power (Watt)
1	3,2	0,003926	9,34
2	3,5	0,005767	12,22
3	2,7	0,003282	5,61
4	2,5	0,002712	4,46
5	3,3	0,004360	10,25
6	2,1	0,002074	2,64
7	2	0,00178	2,28
8	2,3	0,002326	3,47
9	1,9	0,001459	1,96
10	2,3	0,002385	3,47

Based on Table 5, the difference between the total power generated by the generator with the theoretical ratio is too significant. It can be seen in the table, for the highest wind speed of 3,5 m/s, the result of the total power generated by a DC motor or generator is 0,005767 Watt, while the theoretical power potential calculation can reach 12,22 Watt.

The efficiency value of the DC motor or generator is obtained by calculating the output power compared to the input power.

**Table 6.** PLTB Prototype Generator Efficiency

No	Wind Speed(m/s)	Efficiency %
1	3,2	0,04%
2	3,5	0,05%
3	2,7	0,06%
4	2,5	0,06%
5	3,3	0,04%
6	2,1	0,08%
7	2	0,08%
8	2,3	0,07%
9	1,9	0,07%
10	2,3	0,07%
Mean		0,06%

In Table 6, it can be seen that the average generator efficiency only reaches 0.06%. The highest efficiency value was 0.08% at speeds of 2 m/s and 2.1 m/s. The work efficiency of this generator does not reach the ideal work efficiency of the common generator because a good generator has a work efficiency of 80% to 100%.

Based on the results obtained in the PLTB prototype test, it can be analyzed that the stability of wind speed impacts the generator rotation, in which a low and unstable wind speed makes turbine performance not optimal. Moreover, the height factor also impacts generator rotation, where the closer to the ground, the lower the wind speed. The height of the prototype in this study was 70 cm, making the wind energy received is less optimal. Furthermore, other factors making the generator output not reach the expected results are materials, size, angles of the blade used. This prototype used 4 blades made of pipes, making the wind turbine have a weight that made the generator rotation not optimal. The density between blades also becomes an important indicator because it affects the rotation of the turbine. A small number of the blade and placing the blade at a wrong angle can cause the wind to easily cross the blade gap so that the power around the blade is less and results in low speed of blade rotation. Moreover, the diameter of the turbine also has an effect, where the turbine diameter will be directly proportional to the generator output. The wider the blade, it will generate more power.

### Conclusions

Based on the results obtained in the PLTB prototype test, wind speed stability impacts the generator output. The higher the wind speed, the higher the voltage generated.

By using a wind turbine with a surface area of 0.785 m<sup>2</sup>, the theoretical power generated reaches 12.22 watts. The results of the current and voltage test in the PLTB prototype when the highest wind speed of 3.5 obtained the voltage value of 0.426563 V and the current value of 0.01098 A.

The highest generator efficiency that can be generated is when the wind speed of 2.1 m/s and 2 m/s with an efficiency value of only 0.08%. With an efficiency value that is far from the ideal work parameter of the generator, it shows that the PLTB prototype cannot be used in a low and unstable wind speed.

## REFERENCES

- Hamdi, “Angin,” *Energi Terbarukan*, Jakarta : Kencana, 2016, 137–169.
- A. Subandi, “Pembangkit Listrik Tenaga Angin dengan Memanfaatkan Kecepatan Angin Rendah,” pp. 111–115, 2016.
- A. Sheptiawan, D. Notosudjono, and D. Fiddiansyah, “Studi Potensi Energi Angin di Merak Banten untuk Membangkitkan Energi Listrik,” *Univ. Pakuan Bogor*, pp. 1–16, 2001.
- A. Adriani, “Perancangan Pembangkit Listrik Kincir Angin Menggunakan Generator Dinamo Drillini Terhadap Empat Sumbu Horizontal,” *J. INSTEK (Informatika Sains dan Teknol.*, vol. 3, no. 1, pp. 71–80, 2018, doi: 10.24252/instek.v3i1.4821.
- Arridina Susan S. dan Husin Ibrahim, "Energi Angin," *Buku Ajar Energi Baru dan Terbarukan*, Sleman : Deepublish, 2020, 39–68.
- Aksan, S. Bone, and S. Said, “Modul Simulator Turbin Angin Untuk Media Pembelajaran di Laboratorium Sistem Tenaga Listrik,” *Pros. Semin. Has. Penelit.*, vol. 2018, pp. 72–78, 2018.
- R. S. Lubis and M. Gapy, “Pemanfaatan Alternator Sebagai Pembangkit Listrik Tenaga Bayu (PLTB),” *J. Karya Ilm. Tek. Elektro*, vol. 4, no. 4, pp. 19–24, 2019.
- F. Aryanto, I. M. Mara, and M. Nuarsa, “Terhadap Unjuk Kerja Turbin Angin Poros Horizontal,” *Din. Tek. Mesin*, vol. 3, no. 1, pp. 50–59, 2013.
- Sukandarrumidi, Herry Zadrak Kotta, dan Djoko Wintolo. *Energi Terbarukan Konsep Dasar Menuju Kemandirian Energi*, Yogyakarta : Gadjah Mada University Press, 2018
- Iqbal Muhammad dan Adinandra R M Sisdarmanto. *Pembuatan Sistem Pembangkit Listrik Tenaga Angin Berkapasitas 100 Watt*, Yogyakarta : Universitas Islam Indonesia, 2018
- Sunardi dan Sorometa Zeazeli Erwinda, “Perancangan Prototipe Pembangkit Listrik Tenaga Bayu Pada Daerah Tropis Untuk Irigasi Pertanian,” *J. Raya Puspitek, Tek. Elektro*, vol.3, no. 2, pp 206-213, 2020.

## SEE-454 The Urgency of Tropical Studies Based Social Entrepreneurship in the Covid 19 Period

**Aisyah Trees Sandy, Mei Vita Romadon Ningrum, Edwardus Iwantri Goma**

Department of Geography Education, Mulawarman University

*Corresponding Author\*: aisyahkun@gmail.com*

### Abstract

The Covid-19 pandemic has not only caused a health crisis, but has also affected Indonesia's micro and macro economy. The impact of the Covid-19 pandemic has not only suppressed the manufacturing sector, but also the UMKM sector since April 2020. Around 1.5 million employees have been laid off (1.2 million workers are from the formal sector, 265,000 from the informal sector). The business sector that experienced a decline was in the field of agriculture, forestry, and fisheries, which experienced a decline of 3.88%, and the processing industry experienced a decline of 10.97%. In this crisis condition, attention is needed from the government to revive the community's economy by carrying out various social-based economic empowerment programs, especially in tropical forest areas. The tropical rain forest area is an area that has a very important role for life on earth. The diversity of natural and human resources in it is a potential that can be utilized for human survival and the environment. Various environmental and social problems arise due to economic exploitation in tropical rain forest areas causing economic inequality for the surrounding community. People who originally depended on the environment as a source of livelihood lost their livelihoods due to exploitation. Social entrepreneurship is a social action that is integrated in economic activities that produces outcomes in the form of increasing community welfare, eradicating poverty and increasing survival skills of a community. The Covid-19 pandemic which lasted for approximately 2 years caused various economic and social impacts, one of which was the decline in people's economic income. The purpose of this study is to describe the importance of tropical studies-based social entrepreneurship in the Covid-19 period. This research method is a literature review that comes from various journals and relevant research results from various institutions that carry out social entrepreneurship activities. The results of the study concluded that social entrepreneurship is important and needs to be developed to improve people's living standards, be able to eradicate poverty and unemployment through a series of activities that increase skills in community members or society. The development of social entrepreneurship needs to be in synergy with the university curriculum so that it can provide opportunities for students to carry out various social entrepreneurship innovations that are beneficial to society.

**Keywords:** Social entrepreneurship, Tropical studies, Covid 19

### Introduction

The Covid-19 pandemic has not only caused a health crisis, but has also affected Indonesia's micro and macro economy. The impact of the Covid-19 pandemic has not only suppressed the manufacturing sector, but also the UMKM sector since April 2020. Around 1.5 million employees have been laid off (1.2 million workers are from the formal sector, 265,000 from the informal sector). The business sector that experienced a decline was in the field of agriculture, forestry, and fisheries, which experienced a decline of 3.88%, and the processing industry experienced a decline of 10.97% (BPS, 2021). In this crisis condition, attention is needed from the government to revive the community's economy by carrying out various social-based economic empowerment programs, especially in tropical forest areas.

The tropical rain forest area is an area that has a very important role for life on earth. The diversity of natural



the 5<sup>th</sup> ICTROPS

International Conference  
for Tropical Studies and Its Applications

Islamic Development Bank 4in1 Project  
Project Implementation Unit  
University of Mulawarman



IsDB  
البنك الإسلامي للتنمية  
Islamic Development Bank



and human resources in it is a potential that can be utilized for human survival and the environment. Various environmental and social problems arise due to economic exploitation in tropical rain forest areas causing economic inequality for the surrounding community. People who originally depended on the environment as a source of livelihood lost their livelihoods due to exploitation. Social entrepreneurship is a social action that is integrated in economic activities that produces outcomes in the form of increasing community welfare, eradicating poverty and increasing survival skills of a community. The Covid-19 pandemic which lasted for approximately 2 years caused various economic and social impacts, one of which was the decline in people's economic income. The purpose of this study is to describe the importance of tropical studies-based social entrepreneurship in the Covid-19 period.

## Methodology

The subject of this research is the Indonesian population of productive age. This study uses a qualitative descriptive analysis method based on library research (library research). The method used in this article is a qualitative descriptive method based on literature review. Collecting library data, reading, taking notes, and then processing it are the steps in a literature review. Research analysis uses secondary data consisting of research data that has been published on social entrepreneurship in universities and the community. Data on the potential of tropical rain forests to support social entrepreneurship activities.

## Results and Discussion

The COVID-19 pandemic has not only caused a health crisis, but has also affected Indonesia's micro and macro economy. The impact of the Covid 19 pandemic has not only suppressed the manufacturing sector, but also the MSME sector since April 2020. Around 1.5 million employees have been laid off (1.2 million workers are from the formal sector, 265,000 from the informal sector). The business sector that experienced a decline was in the field of agriculture, forestry, and fisheries, which decreased by 3.88%, the processing industry decreased by 10.97% (BPS, 2020). In this crisis condition, attention is needed from the government to revive the community's economy by carrying out various social-based economic empowerment programs, especially in tropical forest areas.

The tropical rain forest area is an area that has a very important role for life on earth. The diversity of natural and human resources in it is a potential that can be utilized for human survival and the environment. Tropical forests are also critical to the achievement of the Sustainable Development Goals (SDGs), which are a set of sustainability targets agreed by countries around the world in 2015. The Life on Land Goals (SDG 15) specifically target the protection, restoration and use of forests and ecosystems land in a sustainable manner, while many of the other SDG targets are related to the existence and healthy functioning of forests. For example, as an important source of income, food security and livelihoods, tropical forests contribute to the Eradication of Poverty (SDG 1) and the Elimination of Hunger (SDG 2). Tropical forests make a major contribution to agricultural production by providing clean water for irrigation, regulating weather patterns so that land is suitable for agriculture, and providing habitat for insects, birds, and bats that pollinate crops. Products harvested directly from forests account for an average of almost a quarter of the household income of families who depend directly on this ecosystem (United Nations, 2015). The potential of tropical rain forests can also be used by the community to improve the quality of the economy including tourism activities, utilization of other forest products.

Environmental and social problems arise due to economic exploitation in tropical rain forest areas causing economic inequality for the surrounding community. People who originally depended on the environment as a source of livelihood lost their livelihoods due to exploitation. The socio-economic problems of the community are also increasing with the Covid-19 pandemic. Many people have lost their jobs and livelihoods.

This condition requires innovative solutions from various parties including local governments to encourage recovery

Social entrepreneurship is a social action that is integrated in economic activities that produces outcomes in the form of increasing community welfare, eradicating poverty and increasing survival skills of a community. The Covid 19 pandemic which lasted for approximately 2 years caused various economic and social impacts, one of which was the decline in people's economic income. Social entrepreneurship can be started on a small scale, for example a community.

Social entrepreneurship also needs to be fostered through the University for students. Social Project activities are very important in building student independence in the midst of the crush of looking for work. Universities must be able to create graduates who are ready to face job competition and are able to create job opportunities by providing entrepreneurial knowledge and skills that have a high level of social sensitivity so that they can change the surrounding environment. The results of research conducted by (Hasanah, 2018) show that there is an impact felt by the object of social entrepreneurship activities carried out by FE UII students through the Social Project Competition.

The Social Project Competition gave rise to 3 winning communities who had different innovations, namely Kali Code diaper processing, Dream Kita, SUKAWA: Etawa Goat Milk Product Innovation. Community empowerment on the banks of the Code River innovates through diaper waste, diaper waste which is processed into planting media which also helps campaign for environmental sustainability. As for our dream, to innovate by establishing educational programs with various learning methods, as well as mapping the potential and the results of the mapping discussed with the residents of Mudal Village to be developed. The third participant made an innovation by making soap from goat's milk. The last element is Economic Activity, in accordance with the goal of developing social entrepreneurship, namely solving problems with business, the Social Project Competition activities must also be able to have an impact on improving the community's economy, in this case harmony between social activities is very necessary, so that independence and sustainability are guaranteed. Social aspects that must be developed are maintaining rights and obligations and establishing a sense of kinship (Prayogo 2017).

This Social Project activity is one of the supports in building student independence in facing challenges and competition in the world of work, especially in the conditions of the Covid-19 pandemic. Through this social entrepreneurship activity, it is hoped that it can foster motivation and enthusiasm for students to create job opportunities, but still prioritize social sensitivity so that they can play a role in their environment.

Social entrepreneurship is one of the options for empowerment activities that can be carried out in tropical rain forest areas to help the socio-economic conditions of the lower middle class community due to the Covid-19 pandemic. Economic recovery and the emergence of new economic resources for communities in tropical rain forest areas need an environmental approach, so that they can be sustainable. Social entrepreneurship activities synergize between sectors, for example, mangrove tourism social entrepreneurship activities which have the aim of generating community economics and conservation.

## Conclusions

Based on the result, it can be concluded that, Social entrepreneurship is important and needs to be developed to improve people's living standards, be able to eradicate poverty and unemployment through a series of activities that increase skills in community members or society. The development of social entrepreneurship needs to be in synergy with the university curriculum so that it can provide opportunities for students to carry out various social entrepreneurship innovations that are beneficial to society.





## ACKNOWLEDGEMENT

The authors are grateful for the funding from Islamic Development Bank (IsBD) Mulawarman University's.

## REFERENCES

- Dees, J. Gregory. 2001. *The Meaning of Social Entrepreneurship*. Kauffman Foundation
- Hasanah, Lak lak Nazhat El. 2018. Pengembangan Kewirausahaan Sosial Pada Perguruan Tinggi Melalui Social Project Competition. *Jurnal Studi Pemuda* 7 (2) : 99
- Nasution,DAD; Erlina, E.;& I Muda, I. 2020. Dampak Pandemi COVID 19 terhadap Perekonomian Indonesia. *Jurnal Benefita : Ekonomi.ejournal.ildikti10.id*
- Palesangi and Muliadi. 2012. "Pemuda Indonesia Dan Kewirausahaan Sosial." *Pemuda Indonesia Dan Keiwarusahaan Sosial* 1(94)
- Patra, S.and S.Nath. 2014. "Social Transformation through Social Entrepreneurship: An Exploratory Study. , XI(1): 7-17." *The IUP Journal of Entrepreneurship Development* 11(1):7-17.
- Prayogo, Caroline. 2017. "Studi Deskriptif Social Entrepreneur Pada Pemilik Agfa Di Sidoarjo, Jawa Timur , Indonesia." *AGORA* 5(1):1-6
- Santoso, Setyanto. 2007. *Peran Social Entrepreneur Dalam Pembangunan*. Malang.
- United Nations. 2015. *Transforming our world: the 2030 Agenda for Sustainable Development*. Sustainable Development Knowledge Platform Available at: <https://sustainabledevelopment.un.org/post2015/transformingourworld>. (Accessed: 6th February 2019)
- Wiguna, Atu Bagus. 2013. "Social Entrepreneurship Dan Socio-Entrepreneurship: Tinjauan Dengan Perspektif Ekonomi Dan Sosial." *Jurnal Ilmiah Mahasiswa FEB* 1(1)

## SEE-462

# Association Analysis of the Number of Dengue Hemorrhagic Fever Cases in East Kalimantan with the Factors of Geographic, Demographic, and Health Using Spearman Rank Correlation

M. Fathurahman<sup>1\*</sup>, Ika Purnamasari<sup>1</sup>, Surya Prangga<sup>1</sup>

Department of Statistics, Mulawarman University, Indonesia

Corresponding Author\*: [fathur@fmipa.unmul.ac.id](mailto:fathur@fmipa.unmul.ac.id)

## Abstract

Dengue Hemorrhagic Fever (DHF) is a mosquito-borne infection caused by the dengue virus, primarily found in the tropics and sub-tropics. The Indonesian country is a tropical climate. During the last three years (2017-2019), there has been an increase in the number of cases of DHF in East Kalimantan Province, Indonesia. This study aims to determine the corresponding factors with the number of DHF cases in East Kalimantan Province, Indonesia, in 2019 by using the Spearman rank correlation method. The result shows that the factors that significantly associated the number of DHF cases in East Kalimantan were the demographic and health factors.

**Keywords:** DHF, Association Analysis, Spearman Rank Correlation.

## Introduction

Dengue Hemorrhagic Fever (DHF) is a severe infectious disease and caused by the dengue virus, which is contaminated through the bites of the *Aedes aegypti* and *Aedes albopictus* mosquitoes, which can cause disruption of the capillary blood vessels and the blood clotting system, resulting in bleeding and death when appropriately handled bad. DHF is commonly found in tropical countries such as Indonesia, and it is still a public health problem in Indonesia, especially in East Kalimantan Province. Based on publications from the Ministry of Health (2020), the number of dengue cases in East Kalimantan Province, in 2017 was 2,237 cases with 8 cases of death. Meanwhile, the Incidence Rate (IR) per 100,000 population is 62.57, and the Case Fatality Rate (CFR) is 0.72%. The cases and deaths in 2018 were increased. There are 3,204 and 17, whereas an IR per 100,000 population of 87.81 and CFR of 0.53%. The number of cases dan death in 2019 was 6,723 cases and 44 cases of death, respectively, whereas the IR per 100,000 population value is 180.66, and a CFR value is 0.65%. This IR value is classified as very high. It shows that the number of cases and deaths due to DHF in East Kalimantan in 2019 significantly increased. Therefore, we investigate the factors related to the DHF cases in East Kalimantan, Indonesia, in 2019.

According to Huda, Mukhaiyar, & Pasaribu (2020), the factors associate with the DHF cases were the climate factor. Meanwhile, Sriningsih, Otok, & Sutikno (2021) discusses the association of the DHF cases with the number of health workers, the number of health facilities, the height of an area, and the density of settlements. Following the factors in the previous studies, this study aims to obtain the factors that have associations with the number of DHF cases in East Kalimantan using the Spearman Rank Correlation (SRC) method. The SRC method is a nonparametric correlation technique that can measure the strength of the relationship between two variables, which have the association form is the monotonic function or the nonlinear function (Croux &



the 5<sup>th</sup> ICTROPS

International Conference  
for Tropical Studies and Its Applications

Islamic Development Bank 4in1 Project  
Project Implementation Unit  
University of Mulawarman



IsDB  
البنك الإسلامي للتنمية  
Islamic Development Bank



Dehon, 2010; Hauke & Kossowski, 2011). Research that discusses DHF cases in East Kalimantan using the SRC method is still scarce and limited. Due to the limited data available, the factors thought to be associated with the number of DHF cases in this study were limited to geographic, demographic, and health factors. Geographical factors are represented by the area and altitude of the area. Meanwhile, demographic and health factors are represented by population density and health workers, respectively. Based on data obtained from the East Kalimantan Provincial Health Office (2020) and the Central Statistics Agency of East Kalimantan Province (2020), the pattern of the relationship between the data on the number of DHF cases and each data on total area, altitude, population density, and the number of health workers tends to be in a monotonic function.

## Methodology

### Research Data

The secondary data was used in this research. The data was got from the Central Bureau of Statistics of East Kalimantan Province (2020). The research unit was ten districts/cities in East Kalimantan Province, Indonesia, in 2019. The data obtained are the number of DHF cases ( $U$ ), the total area ( $V_1$ ), the area altitude ( $V_2$ ), population density ( $V_3$ ), and the number of health workers ( $V_4$ ).

### Data Analysis

The steps of data analysis are as follows:

Descriptive analysis, this step aims to determine the characteristics of data, that is presented in the form of tables, graphs, or diagrams. Association analysis of the number of DHF cases was carried out with the following steps:

- Identifying the relationship pattern for each pair of variables, namely  $U$  and  $V_1$ ;  $U$  and  $V_2$ ;  $U$  and  $V_3$ ; and  $U$  and  $V_4$  using a scatter plot.
- Calculate the value of the Spearman correlation coefficient for each pair of variables  $U$  and  $V_1$ ;  $U$  and  $V_2$ ;  $U$  and  $V_3$ ; and  $U$  and  $V_4$ .
- Perform hypothesis testing for each pair of variables  $U$  and  $V_1$ ;  $U$  and  $V_2$ ;  $U$  and  $V_3$ ; and  $U$  and  $V_4$ , which aims to obtain variables that are significantly related to  $U$ .
- Interpret each relationship between  $U$  and  $V_1$ ,  $V_2$ ,  $V_3$ , and  $V_4$ .
- Make conclusions.

### Spearman Rank Correlation Method

Spearman Rank Correlation (SRC) method is a statistical measure of the strength of *monotonicity* relationship between two variables (Kloke & McKean, 2015). Charles Edward Spearman founded the SRC method in 1904 (Conover, 1999). The data form of the SRC method may consist of a bivariate random sample of size  $n$ ,  $(U_1, V_1)$ ,  $(U_2, V_2)$ , ...,  $(U_n, V_n)$ . Suppose  $R(U_i)$  is the rank of  $U_i$  as compared with the other  $U$  values, for  $i = 1, 2, \dots, n$ . That is,  $R(U_i) = 1$  if  $U_i$  is the smallest of  $U_1, U_2, \dots, U_n$ ,  $R(U_i) = 2$  if  $U_i$  is the second smallest, and so on, with rank  $n$  being assigned to the largest of the  $U_i$ . Similarly, let  $R(V_i)$  equal 1, 2, ..., or  $n$ , depending on the relative magnitude of  $V_i$  as compared with  $V_1, V_2, \dots, V_n$ , for each  $i$ .

According to Conover (1999), the coefficient correlation value of the SRC method can be obtained by

$$r_S^* = \frac{\sum_{i=1}^n R(U_i)R(V_i) - n\left(\frac{n+1}{2}\right)^2}{\left(\sum_{i=1}^n R(U_i)^2 - n\left(\frac{n+1}{2}\right)^2\right)^{\frac{1}{2}} \left(\sum_{i=1}^n R(V_i)^2 - n\left(\frac{n+1}{2}\right)^2\right)^{\frac{1}{2}}} \quad (1)$$

If there are no ties, an equivalent but computationally easier form is given by

$$r_S^* = 1 - \frac{\sum_{i=1}^n (R(U_i) - R(V_i))^2}{n(n^2 - 1)} = 1 - \frac{6W}{n(n^2 - 1)} \quad (2)$$

where  $W$  represents the entire sum in the numerator. This form is equivalent only if there are no ties. If there are many ties use Equation (1). If a moderate number of ties is present in the data, Equation (2) is recommended for computational simplicity since the difference between Equations (1) and (2) will be slight.

However, the coefficient correlation of the SRC method has positive or negative values (i.e.,  $-1 \leq r_S^* \leq 1$ ) and the strength of correlation. The positive and negative values of the SRC method are sometimes called the direct correlation. The interpretation of the direct and strength of the correlation is presented in Table 2.

**Table 2.** Interpretation of the Correlation Coefficient of the SRC Method

Coefficient Correlation Values	Interpretation
$r_S^* = 1$	Perfect correlation
$0.9 \leq r_S^* < 1$	Very high correlation
$0.7 \leq r_S^* < 0.9$	High correlation
$0.5 \leq r_S^* < 0.7$	Moderate correlation
$0.3 \leq r_S^* < 0.5$	Low correlation
$0 < r_S^* < 0.3$	Little if any correlation
$r_S^* = 0$	No correlation

The SRC method is often used as a test statistic to test for independence between two random variables. The test statistic is given by Equation (1) or Equation (2). Exact quantiles of  $r_S^*$  when  $U$  and  $V$  are independent are given in Spearman's table for  $n \leq 30$  and no ties. For larger  $n$ , or many ties, the  $q$ th quantile of  $r_S^*$  is given approximated by

$$W_q = \frac{Z_q}{\sqrt{n-1}} \quad (3)$$

where  $Z_q$  is the standard normal quantile found in the standard normal distribution table (Conover, 1999).

The coefficient correlation of the SRC method is sensitive to some types of dependence, so it is better to be specific as to what type of dependence may be detected. Therefore, the hypotheses take the following form:

Two-Tailed Test

$H_0$  : The  $U_i$  and  $V_i$  are mutually independent

$H_1$  : Either (a) there is a tendency for the larger values of  $U$  to be paired with the larger values of  $V$ , or (b)

there is a tendency for the smaller values of  $U$  to be paired with the larger values of  $V$   
Reject  $H_0$  at the level of significance ( $\alpha$ ) if the absolute value of  $r_s^*$ ,  $|r_s^*|$ , is greater than its  $1 - \alpha/2$  obtained from the Spearman's table or Equation (3). The approximate two-tailed  $P$ -values is

$$P\text{-value} = 2P(Z \geq |r_s^*| \sqrt{n-1}) \quad (4)$$

using the table of standard normal distribution (Conover, 1999).

Lower-Tailed test for Negatif Correlation

$H_0$  : The  $U_i$  and  $V_i$  are mutually independent

$H_1$  : There is a tendency for the smaller values of  $U$  to be paired with the larger values of  $V$ , and vice versa

Reject  $H_0$  at the level  $\alpha$  if  $r_s^* < -W_{1-\alpha}$ , where  $W_{1-\alpha}$  is found in Spearman's table or from Equation (3). The approximate lower-tailed  $P$ -value is

$$P\text{-value} = P(Z \leq r_s^* \sqrt{n-1}) \quad (5)$$

using the table of standard normal distribution (Conover, 1999).

Upper-Tailed Test for Positive Correlation

$H_0$  : The  $U_i$  and  $V_i$  are mutually independent

$H_1$  : There is a tendency for the larger values of  $U$  and  $V$  to be paired together

Reject  $H_0$  at the level  $\alpha$  if  $r_s^* > W_{1-\alpha}$ , where  $W_{1-\alpha}$  is found in the Spearman's table or Equation (3). The approximate upper-tailed  $P$ -value is

$$P\text{-value} = P(Z \geq r_s^* \sqrt{n-1}) \quad (6)$$

using the table of standard normal distribution (Conover, 1999).

### Dengue Hemorrhagic Fever

Dengue was a mosquito-borne viral contamination found in tropical and sub tropical climates worldwide, primarily urban and semi-urban. The virus responsible for causing dengue was called dengue virus (DENV). There are four DENV serotypes, meaning that it is possible to be infected four times. The clinical manifestations of DENV contamination range from asymptomatic contamination or a mild flu-like syndrome, also referred as dengue fever (DF), to the more severe and life-threatening forms, dengue hemorrhagic fever (DHF) and dengue shock syndrome (WHO, 2011).

DHF was defined by having at least the first two of the following four clinical manifestations of: 1) sudden onset acute fever of 2 to 7 days duration; 2) unconstrained hemorrhagic positive Tourniquet test; 3) hepatomegaly; and 4) circulatory system failure, in combination with hematological criteria of thrombocytopenia ( $\leq 100,000$  cells/mm<sup>3</sup>) and an increased hematocrit over 20%. Suspected DHF cases according to those point of reference were further evaluated which DHF cases were grouped into probable and confirmed cases. A probable case was referred as clinically suspect patients espoused by positive dengue serology (positive anti-DENV IgM in critical or convalescent serum sample and a fourfold intensify in IgG between the critical and the convalescent samples) or when an expected DHF patient was linked at the exact location and time to other confirmed DHF cases. A confirmed cases was referred as a case with laboratoty confirmation through DENV isolation, or viral antigen or RNA detection in serum. This categorization has continually been used nationwide by hospitals and Community Health Centres in Indonesia. All probable or confirmed DHF cases were reported and included in the surveillance system (Karyanti et al., 2014; Harapan et al., 2019).

## Results and Discussion

### Analysis of Descriptive Statistics

The descriptive statistics of research data are displayed in Table 3.

**Table 3.** Descriptive Statistics of Research Data

Notation	Variables	Minimum	Maximum	Mean	Standard Deviation
$U$	The number of DHF cases	66	1838	672	122
$V_1$	The total area	163.1	31051.7	12734.7	11494.05
$V_2$	The area altitude	5.98	174.63	54.1	65.03897
$V_3$	Population density	1.36	1297.74	379.65	579.0708
$V_4$	The number of health workers	287	2960	1381	903

Based on Table 3, the highest number of DHF cases was in Balikpapan City. The lowest was in Mahakam Ulu District. Furthermore, the largest area was Kutai Timur District, and the smallest was Bontang City. The highest area was Mahakam Ulu District, whereas the smallest was Kutai Timur District. The most density of population was Balikpapan City, and the sparsely was Mahakam Ulu District. Meanwhile, most health workers in Samarinda City, and a few were in Mahakam Ulu District.

### Association Analysis for The Number of DHF Cases

The initial step of the association analysis was to identify the relationship pattern using the scatter plots for each pair of variables, namely the number of DHF cases and the total area (Figure 1a); the number of DHF cases and the area altitude (Figure 1b); the number of DHF cases and population density (Figure 1c); and the number of DHF cases and the number of health workers (Figure 1d). Figure 1 shows that the relationship pattern of paired data has a monotonic (nonlinear) form. Therefore, the SRC method was appropriately used.

Spearman's test statistic performed hypothesis testing for the SRC method. The Spearman's coefficient correlation and Spearman's test statistic values were employed. Based on data analysis using R software with *stats* package, the results of Spearman's coefficient correlation and *P*-values were presented in Table 4.

**Table 4.** Spearman's Coefficient Correlation ( $r_s^*$ ) and Probability (*P*) Values of Spearman's Test Statistic for the Number of DHF Cases

Variables	$r_s^*$	<i>P</i> -Value
$U$ and $V_1$	-0.3333	0.3488
$U$ and $V_2$	-0.4012	0.2505
$U$ and $V_3$	0.8061	0.0082*
$U$ and $V_4$	0.8667	0.0027*

\*) Significant at the 5% significance level.

Table 4 shows the statistical tests of the two paired variables (i.e.,  $U$  and  $V_3$  and  $U$  and  $V_4$ ) have the *P*-values less than the significant level. This results indicate that the number of DHF cases in East Kalimantan was significantly associated with population density and health workers. The strong correlation of the number of DHF cases with population density and health workers was very strong, respectively.



the 5<sup>th</sup> ICTROPS

International Conference  
for Tropical Studies and Its Applications

Islamic Development Bank 4in1 Project  
Project Implementation Unit  
University of Mulawarman



IsDB  
البنك الإسلامي للتنمية  
Islamic Development Bank

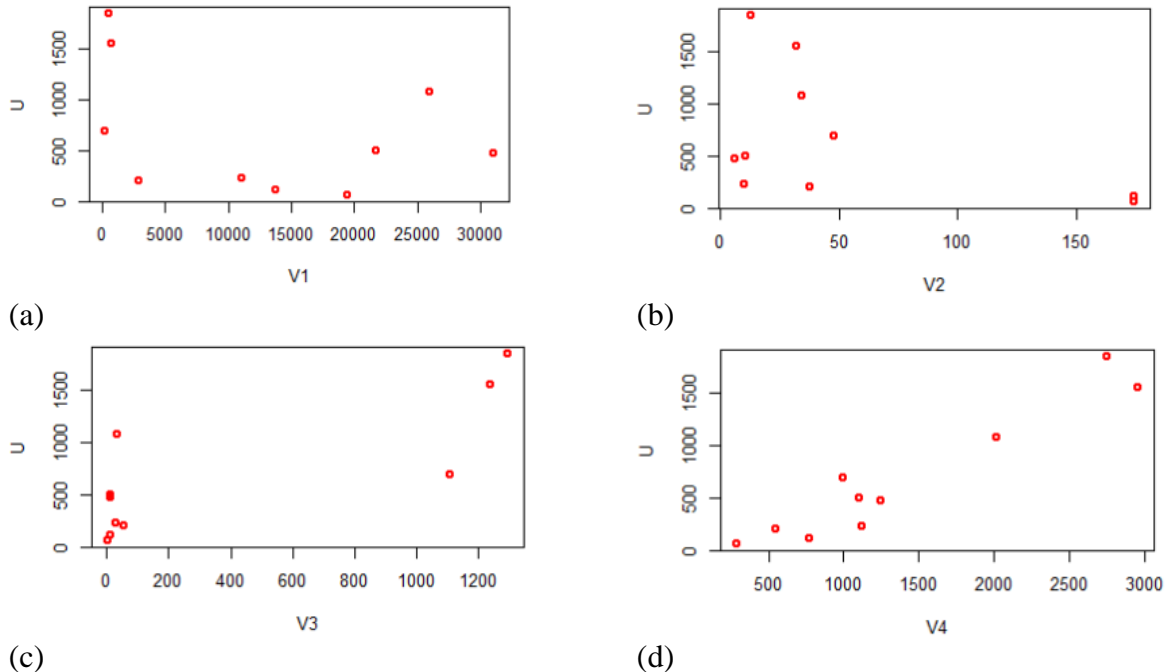

**Figure 1.** The Relationship Pattern of Research Data

## Conclusions

During the last three years (2017-2019), there has been an increase in cases and deaths due to DHF in East Kalimantan Province, Indonesia. The relationship pattern of the number of DHF cases in East Kalimantan, Indonesia, in 2019 with the factors of geographic, demographic, and health was a monotonic function. Therefore, It can be analyzed by the SRC method. The factors that have significant association with the number of DHF cases in East Kalimantan, Indonesia, in 2019 were the demographic and health factors (i.e., population density and the number of health workers).

## ACKNOWLEDGEMENT

We would like to thank the Islamic Development Bank 4in1 Project, Project Implementation Unit Mulawarman University for funding this work.

## REFERENCES

- Conover, W. J. (1999). *Practical Nonparametric Statistics* (3rd ed.). New York: John Wiley & Sons.
- Croux, C., & Dehon, C. (2010). Influence functions of the Spearman and Kendall Correlation Measures. *Stat. Methods. Appl.*, 497-515.



the 5<sup>th</sup> ICTROPS

International Conference  
for Tropical Studies and Its Applications

Islamic Development Bank 4in1 Project  
Project Implementation Unit  
University of Mulawarman



IsDB  
البنك الإسلامي للتنمية  
Islamic Development Bank



- Harapan, H., Michie, A., Mudatsir, M., Sasmono, R. T., & Imrie, A. (2019). Epidemiology of Dengue Hemorrhagic Fever in Indonesia: Analysis of five decades data from the National Disease Surveillance. *BMC Research Notes*, 12(350), 1-6.
- Hauke, J., & Kossowski, T. (2011). Comparison of Values of Pearson's and Spearman's Correlation Coefficients on the Sama Sets of Data. *Quaestiones Geographicae*, 30(2), 87-93.
- Huda, N. M., Mukhaiyar, U., & Pasaribu, U. S. (2020). Forecasting Dengue Fever Cases Using Autoregressive Distributed Lag Model with Outlier Factor. *Proceeding of IICMA 2019* (pp. 1-7). Pontianak, Indonesia: AIP Publishing.
- Karyanti, M. R., Uiterwaal, C. S., Kusriastuti, R., Hadinegoro, S. R., & Rovers, M. M. (2014). The Changing Incidence of Dengue Haemorrhagic Fever in Indonesia: A 45-year registry-based analysis. *BMC Infectious Diseases*, 1-7.
- Kloke, J., & McKean, J. W. (2015). *Nonparametric Statistical Methods Using R*. Boca Raton: CRC Press.
- Ministry of Health. (2020). *Health Profile of Indonesia 2019*. Jakarta: Ministry of Health.
- Sriningsih, R., Otok, B. W., & Sutikno. (2021). Factor Affecting the Number of Dengue Fever Cases in West Sumatera Province Using the Multivariate Adaptive Regression Splines (MARS) Approach. *Proceeding of ICW-HDDA-X 2020* (pp. 1-6). Jatinangor, Indonesia: IOP Publishing.
- The Central Statistics Agency of East Kalimantan Province. (2020). *East Kalimantan Province in Figures 2020*. Samarinda: The Central Statistics Agency of East Kalimantan Province.
- The East Kalimantan Provincial Health Office. (2020). *Health Profile of East Kalimantan Province 2019*. Samarinda: The East Kalimantan Provincial Health Office.
- WHO. (2011). *Comprehensive Guidelines for Prevention and Control of Dengue and Dengue Haemorrhagic Fever*. New Delhi: WHO Regional Publication SEARO.



## SEE-469

### Added Value Analysis of *Eleutherine americana* M. Herbal Tea Mursidah \*

**Sofia Utari, Muhammad Erwan Suriaatmaja**

Faculty of Agriculture, Mulawarman University

Corresponding Author\*: [mursidah.spm@gmail.com](mailto:mursidah.spm@gmail.com)

#### Abstract

The tropics are rich in natural resources, both from flora and fauna. *Eleutherine americana* M. is one of them. Local people in Borneo use this onion as a medicine for various diseases. Role agroindustry, in an effort to maintain primary products into processed products to increase the added value is very necessary. The added value of a product very important to increase the selling price. Including processing *Eleutherine americana* M. into herbal tea. The aim of this research was to analyze the added value of *Eleutherine americana* M. processing into herbal teas. Data were collected through in-depth interviews with herbal tea processing business owners. The results showed that the added value obtained was IDR 156,017.56 kg<sup>-1</sup>, value added ratio 75.15%, the income earned is IDR 140,405.72 kg<sup>-1</sup> with a income rate of 89.99%. The conclusion of this research is the processing of *Eleutherine americana* M. into herbal teas are able to provide added value to *Eleutherine americana* M.

**Keywords:** Added value, *Eleutherine americana* M., herbal tea.

#### Introduction

Herbal plants are medicinal plants that are safe for consumption and easy to find. Herbal plants are efficacious for curing certain diseases because they have active substances for treatment. *Eleutherine americana* M. is one of the herbal plants consisting of phytochemical compounds such as alkaloids, glycosides, flavonoids, phenolics, steroids and tannins (Saputra, 2011). Empirically, *Eleutherine americana* M. have been used by local people as a medicine for various diseases such as colon cancer, breast cancer, diabetes mellitus, hypertension, lowering cholesterol, medicine for ulcers, stroke and abdominal pain after childbirth (Indrawati, 2013). Opportunities for processing agricultural products that have pharmaceutical potential are even greater with the movement to go back to nature, through the use of medicines made from natural ingredients. So as to be able to open up opportunities for the processing industry based on *Eleutherine Americana* M. (Drianti, 2019; Saragih, 2018). In agribusiness, agro-industry is an activity that utilizes primary products as raw materials to be processed in such a way that they become semi-finished or finished products and can be consumed. Agro-industry made from agricultural products that are perishable, seasonal, and only found in certain areas, can be converted into a product that will later change shape, so as to increase the added value of these agricultural products (Wardhani et al., 2019). Creativity and innovation are always evolving to create added value from a product that sells well in the market. The aim of this research was to analyze the added value of *Eleutherine Americana* M. processing into herbal teas.

## Methodology

This research was conducted from March to September 2020. The research location is in the Teawai herbal tea business in Jahab Village, Tenggara District, Kutai Kartanegara Regency. The data obtained in this study are primary data and secondary data. Primary data were obtained through direct observation to the research location and in-depth interviews with respondents, namely the owner of the Teawai herbal tea business, guided by a questionnaire that was prepared according to the research objectives. Primary data include output value, cost of raw materials, and costs of other supporting materials which determine the amount of added value produced. The research sample was taken using purposive sampling method. The data analysis method used in this study is the quantitative analysis method, with the following calculations (Suratiyah, 2015; Rosyidi, 2020):

### Total Cost

Total cost is the cost incurred by producers to produce goods and services, both costs that are fixed and costs that can change.

$$TC = TFC + TVC \quad (1)$$

Where :

TC = Total Cost

TFC = Total Fixed Cost TVC = Total Variable Cost

### Total revenue

Total revenue is the product of the product price and quantity.

$$TR = P \cdot Q \quad (2)$$

Where :

TR = Total Revenue

P = Price

Q = Quantity

### Income

Income is the difference between total revenue and total cost

$$I = TR - TC \quad (3)$$

Where :

I = Income

TR = Total Revenue

TC = Total Cost

### Value-added

To determine the added value of the business of making Teawai herbal tea, the Hayami method was used.



the 5<sup>th</sup> ICTROPS

International Conference  
for Tropical Studies and Its Applications

Islamic Development Bank 4in1 Project  
Project Implementation Unit  
University of Mulawarman



IsDB  
البنك الإسلامي للتنمية  
Islamic Development Bank



Table 1. The Hayami method

Variable Value

<b>I. Output, Input dan Price</b>	
1. Output (kg month <sup>-1</sup> )	1
2. Input (kg month <sup>-1</sup> )	2
3. Labor (Hour months <sup>-1</sup> )	3
4. Conversion Factor	4 = 1/2
5. Labor Coefficient (IDR kg <sup>-1</sup> )	5 = 3/2
6. Output Price (IDR kg <sup>-1</sup> )	6
7. Labor Wages (IDR bulan <sup>-1</sup> )	7
Revenue and Income	
8. Raw Material Prices (IDR kg <sup>-1</sup> )	8
9. Other Input Contributions (IDR kg <sup>-1</sup> )	9
10. Output Value (IDR kg <sup>-1</sup> )	10 = 4x6
11. a. Added Value (IDR kg <sup>-1</sup> )	11a = 10-9-8
b. Value Added Ratio (%)	11b = (11a/10) x 100%
12. a. Labor Income (IDR kg <sup>-1</sup> )	12a = 5x7
b. Labor Share (%)	12b = (12a/11a) x 100%
13. a. Income (IDR kg <sup>-1</sup> )	13a = 11a - 12a
b. Income Rate (%)	13b = (13a/11a) x 100%

Source : Hayami *et al*, (1987)

## Results and Discussion

### The processing and packaging of herbal tea

Fresh *Eleutherine americana* M. are cleaned of roots, leaves, and soil that are still attached. Then wash it clean. *Eleutherine americana* M. that have been washed using clean water, then cut using an *Eleutherine americana* M. cutting machine. Then the *Eleutherine americana* M. are placed in the pan. The *Eleutherine americana* M. slices on the baking sheet will then be put in the oven to dry. *Eleutherine americana* M. were oven-baked for 40minutes at a temperature below 70°C.

The dried *Eleutherine americana* M.s are cooled for a few minutes until the *Eleutherine americana* M. are completely ready to be packed. Then put in a tea bag and weighed with a weight of 1.5 g. After that enter the sealing process. The sealed tea bags are put into foil packswith a total of 18 tea bags and packed into tea packaging boxes that have been labeled with an

expiration date. The expiration period for herbal teas is 1 year after the date of production. The last process is wrapping, which is giving clear plastic to the packaging box.

### Production costs

Production costs in making herbal tea from *Eleutherine americana* M. are calculated from various costs, including raw material costs, equipment depreciation costs, labor costs, and other costs. Details of production costs can be seen in Table 2 below.

**Table 2.** Production costs

No	Cost	Total Cost (IDR month <sup>-1</sup> )
1.	Raw material costs	760,000.00
2.	Equipment depreciation costs	344,527.78
3.	Labor costs	1,186,500.00
4.	Other costs	2,815,900.00
	Jumlah	5,106,927.78

Production costs calculated in this study include variable costs and fixed costs. Variable costs include raw material costs, other costs and labor costs, while fixed costs include equipment depreciation costs.

Based on the results of research that has been carried out, the cost of raw materials in this herbal tea processing business is IDR 760,000 per month, with the purchase price of raw materials being IDR 10,000 kg<sup>-1</sup>, and the raw materials used are 76 kg per month. Other expenses incurred IDR 2,815,900 per month. These other costs consist of gas, electricity, tea bags, tea packaging boxes and water.

There are 3 labors who are used in the herbal tea production process. Types of work include cleaning of cooling and packaging. The labor wages for cleaning to cooling are IDR 79,100 per day and labor wages for packaging are IDR 79,100 per day, with total labor costs of IDR 1,186,500 per month.

### Productions, Revenues and Incomes

In March 2020 the production process was carried out 5 times, with a total production of 789 packages. In one package, there are 18 tea bags, with each tea bag weighing 1.5 g. The net weight in one package is 27 g. The price of a pack of tea is IDR 20,000. Details of production and acceptance can be seen in Table 3 below.

**Table 3.** Productions and revenues

Descriptions	Amount
Production quantity (packaging)	789
Price (IDR packaging <sup>-1</sup> )	20,000
Revenues (IDR month <sup>-1</sup> )	15,780,000

Revenue is the difference between revenue and production costs. The details of herbal tea business income are detailed in Table 4 below.



the 5<sup>th</sup> ICTROPS

International Conference  
for Tropical Studies and Its Applications

Islamic Development Bank 4in1 Project  
Project Implementation Unit  
University of Mulawarman



IsDB  
البنك الإسلامي للتنمية  
Islamic Development Bank



Table 4. Details of production costs, revenues and incomes

No	Descriptions	Amount (IDR months <sup>-1</sup> )
1.	Production costs	5,106,927.78
2.	Revenues	15,780,000.00
3.	Incomes	10,67,072.22

Income is the difference between revenue and the total costs incurred during production. The amount of revenue earned by the herbal tea business is IDR 15,780,000 per month, production cost is IDR 5,106,927.78 per month, so that the net income is IDR10,673,072.22 per month.

### Value-added

The added value is obtained from the processing of *Eleutherine americana* M. into herbal tea products. The following is the calculation of the added value of the herbal tea business using the Hayami method.

Table 5. The added value of herbal tea

Variable		Value
<b>I. Output, Input, and Price</b>		
1. Output (kg month <sup>-1</sup> )	1	21.30
2. Input (kg month <sup>-1</sup> )	2	76.00
3. Labor (hour month <sup>-1</sup> )	3	105.00
4. Conversion Factor	4=1/2	0.28
5. Labor Coefficient (IDR kg <sup>-1</sup> )	5= 3/2	1.38
6. Output Price (IDR kg <sup>-1</sup> )	6	740,740.00
7. Labor Wages (IDR hour <sup>-1</sup> )	7	11,300.00
<b>II. Revenue and Income</b>		
8. Raw Material Prices (IDR kg <sup>-1</sup> )	8	10,000.00
9. Other Input Contributions (IDR kg <sup>-1</sup> )	9	41,584.57
10. Output Value (IDR kg <sup>-1</sup> )	10= 4x6	207,602.13
11. a. Added Value (IDR kg <sup>-1</sup> )	11a= 10-9-8	156,017.56
b. Value Added Ratio (%)	11b= (11a/10)x100%	75.15
12. a. Labor Income (IDR kg <sup>-1</sup> )	12a= 5x7	15,611.84
b. Labor Share (%)	12b= (12a/11a)x100%	10.01
13. a. Income (IDR kg <sup>-1</sup> )	13a= 11a-12a	140,405.72
b. Income Rate (%)	13b= (13a/11a)x100%	89.99

Based on the calculation of added value in Table 5. Calculation of added value in Teawai herbal tea products is carried out for 1 month, it is known that the production (output) of the Teawai herbal tea business is 21.3 kg month<sup>-1</sup> dry *Eleutherine americana* M. from the use of



the 5<sup>th</sup> ICTROPS

International Conference  
for Tropical Studies and Its Applications

Islamic Development Bank 4in1 Project  
Project Implementation Unit  
University of Mulawarman



IsDB  
البنك الإسلامي للتنمية  
Islamic Development Bank



input 76 kg month<sup>-1</sup> wet *Eleutherine americana* M., with a selling price of IDR 740,740 kg<sup>-1</sup>. This output price is obtained from the calculation of 1 kg of dried *Eleutherine americana* M., divided by 27 g times the price per package. The number of labor hours needed in 1 month of production is 105 hours. The herbal tea output value is IDR 207,602.13 kg<sup>-1</sup>. Direct labor income is IDR 15,611.84 kg<sup>-1</sup> with a labor share of 10.01%. The price of *Eleutherine americana* M.s as input used is IDR 10,000 kg<sup>-1</sup>. The contribution of other inputs used in the production process per kg of raw materials is IDR 41,584.57. Calculation of the price of other inputs, namely other costs, which include fuel and packaging. Value added results are obtained by reducing the value of the output with the price of raw materials and other input contributions. The added value of processing *Eleutherine americana* M. into tea is IDR 156,017.56 kg<sup>-1</sup> with an added value ratio of 75.15%. The amount of profit obtained is IDR 140,405.72 kg<sup>-1</sup>, with a profit rate of 89.99% of the product value (output).

## Conclusions

Based on the results of the study it can be concluded that the production costs incurred from the herbal tea business are IDR 5,106,927.78 per month. The revenue earned is IDR 15,780,000 per month and the income is IDR 10,673,072.22 per month. The added value obtained from processing *Eleutherine americana* M. into herbal tea is IDR. 156,017.56 kg<sup>-1</sup>. While the added value ratio is 75.15%.

## ACKNOWLEDGEMENT

The author would like to thank the owner of the Teawai Herbal Tea business and all parties who have contributed to this research.

## REFERENCES

- Dewi, H. N. P. , Satriawan, I. K. , and Wrasati, L. P. 2017. Analysis of value added processing and financial feasibility of beverage herbal powder onion berlian (*Eleutherine americana* Merr). *Jurnal Rekayasa dan Manajemen Agroindustri*. Vol 5 (2): 70-73.
- Drianti, A. 2019. Supply of Dayak Onion Herbal Tea (Tisane) in Jahab Village, Tenggara District. *Jurnal Agribisnis Fakultas Petanian Unika*. Vol 19 (1): 67-71.
- Hayami, Y., T. Kawagoe, Y. Marooka, dan M. Siregar. 1987. *Agriculture Marketing and Processing In Upload Java: A Perspective from A Sund a Village*. CGPRT Center. Bogor.
- Indrawati, N.L. 2013. *Onion Dayak The Magic Bulb Conquer Various Diseases*. Agromedia. Jakarta.
- Rosyidi, S. 2020. *Introduction to economic theory: Approaches to micro and macroeconomic theory*. Raja Grafindo, Jakarta.
- Saputra, S.H., 2011. Phytochemical Characteristics and Bioactivity of Tiwai Onion (*Eleutherine americana* Merr.) "Medical Plants from East Kalimantan". *Jurnal Riset*



*Tegnologi Industri.* Vol 5 (9): 44-45.

<http://ejournal.kemenperin.go.id/jrti/article/viewFile/1494/1238>

Saragih, B. 2018. *Bawang Dayak (tiwai) Sebagai Pangan Fungsional.* CV Budi Utama. Yogyakarta.

Suratiah, K. 2015. *Ilmu Usahatani.* Penebar Swadaya. Jakarta.

Wardhani, R. M., Wuryantoro and Adinurani, P. G. 2019. Value Added Analysis of Yard- Based Agroindustry for Food Security. IOP Conference Series Earth and Environmental Science 347:012028.

## SEE-487

# Economic Empowerment of the Muang Ilir Village Community Through “MILTOVIL” (Muang Ilir Ecotourism Village)

**Niky Aulia Putri<sup>1</sup>, Imam Wijayadi<sup>2</sup>, Teguh Pribadi<sup>3</sup>, Zenia Lutfi Kurniawati<sup>4\*</sup>**

Faculty of Teacher Training and Education, Mulawarman University, Indonesia

*Corresponding Author\*:* [zenia.lutfi@fkip.unmul.ac.id](mailto:zenia.lutfi@fkip.unmul.ac.id)

### Abstract

Corona virus 2019 (COVID-19) has infected millions of people around the world. The impact on the economy is expected to be large and can cause the economy of a country to slump, including Indonesia. The city of Samarinda, located in East Kalimantan Province, has also felt the economic impact of COVID-19, especially in the tourism sector. A regional development strategy in Samarinda is needed to be able to restore economic productivity. The purpose of this study was to determine the potential and strategy of developing an ecotourism village that can be used in one of the villages in Samarinda City, namely Muang Ilir Village, and to determine the effect of developing Muang Ilir Village into an ecotourism village on regional economic recovery. The research was carried out in January-February 2021 in Muang ilir Village, North Lempake, North Samarinda District, Samarinda City, East Kalimantan. Data collection techniques used by the author are observation, questionnaires, interviews and documentation. The author conducted a SWOT analysis (Strength, Weakness, Opportunity, and Threats) as a basic support for research on the development of Muang Ilir Village into an ecotourism village. From the SWOT analysis that the author has done, it can be seen that Muang Ilir Village has strength or potential in natural beauty, plants, and rivers. The weaknesses of Muang Ilir Village are the absence of public transportation and traffic signs, inadequate huts and the absence of public facilities. Muang Ilir Village has the opportunity as an ecotourism village in Samarinda City which attracts tourists' attention so as to improve the community's economy. Threats that may occur are various activities that can damage the environment and natural disasters such as floods to land fires. The strategy of developing Muang Ilir Village into an ecotourism village can be done by dividing the area into three blocks. Intensive use blocks include rice fields and vacant land, divided into core zones covering infrastructure improvement as well as providing public facilities and supporting zones including procurement of souvenir stalls, rice fields, rice fields bridges, vegetable museums to local specialties. Limited use blocks utilize vacant land for nurseries with special tourism purposes for research purposes. The protection block covers the Karang Mumus River and its surrounding watershed for educational tourism. Based on survey obtained 100% of the people of Muang Ilir Village support and believe that the development of an ecotourism village will increase the economic productivity of the community. This is also supported by the results survey by 96.2% the people of Samarinda City who are interested in visiting and buying products produced by the people of Muang Ilir Village.

**Keywords:** Muang Ilir Village, Ecotourism Village, Tourism Potential, Development Strategy, SWOT

### Introduction

The World Health Organization (WHO) explains that Corona viruses (Cov) are viruses that infect the respiratory system. This viral infection is called COVID 19. Corona virus causes illness from the common





the 5<sup>th</sup> ICTROPS

International Conference  
for Tropical Studies and Its Applications

Islamic Development Bank 4in1 Project  
Project Implementation Unit  
University of Mulawarman



IsDB  
البنك الإسلامي للتنمية  
Islamic Development Bank



cold to more severe illnesses such as Middle East Respiratory Syndrome (MERS-CoV) and Severe Acute Respiratory Syndrome (SARS-CoV). So far, 188 countries have confirmed that they have the Corona virus. The spread of the Corona virus which has spread to various parts of the world has an impact on the Indonesian economy, both in terms of trade, investment, and tourism. Corona virus disease 2019 (COVID-19) has infected millions of people worldwide. The impact on the economy is expected to be large and can cause a country's economy to slump. The Corona virus or Corona virus disease 2019 (Covid-19) has made the Indonesian economy contract. The impact of the Corona Virus or Covid-19 seems to have an impact on all sectors, especially tourism and other sectors (Fahrika, 2020).

According to Fahrika (2020) during the first three months (first quarter), namely January to March 2020, the Covid 19 virus spread very quickly in Indonesia and had a considerable impact on economic activities in Indonesia. One of the provinces in Indonesia, namely East Kalimantan, has also felt the impact of the Covid 19 virus on the regional economy. This was acknowledged by the Governor of East Kalimantan, H. Isran Noor, who said that based on data from the Social Service and BPS, the number of poor people has only increased due to Covid 19, even the addition could reach 100 percent of the total data.

Samarinda City, which is the capital of East Kalimantan Province, also experienced an economic decline, especially in the tourism sector during the pandemic. According to Maulana (2020) tourism is one of the largest industries that are growing rapidly in the world. Tourism is used as a potential source of foreign exchange and a significant source of employment. Therefore, a strategy for developing the tourism sector in Samarinda City is needed to stabilize the regional economy.

Muang Ilir Village, which is located in Lempake Village, North Samarinda District, Samarinda City, East Kalimantan, has a good geographical location so that it has a lot of tourism potential that can be developed into an ecotourism village to help the regional economy. According to Tisnawati (2019), ecotourism is a form of travel to unspoiled areas that aims to understand the culture and natural history of the environment, maintain ecosystem integrity, while creating economic opportunities to make conservation and natural resources profitable for local communities. In this area, the people still have traditions and culture that are still relatively original. In addition, several supporting factors such as typical food, agricultural systems and social systems also color a tourist village area. Apart from these factors, pristine and preserved nature and environment is one of the most important factors of a tourist destination.

In Muang Ilir Village, the potential for agricultural products which in addition to being used for food needs can also be developed into a natural tourist attraction without damaging or changing both socially and culturally. Rice fields with direct views towards the hills can be a capital in attracting tourists. The existence of the Karang Mumus River and the watershed that stretches in Muang Ilir Village adds to the potential for water tourism that can be developed into riverbanks. In addition, the Karang Mumus River School is an attraction for tourists to visit. The village also has a cultured community that can attract tourists. In addition, it has great opportunities to develop in infrastructure and other supporting facilities.



the 5<sup>th</sup> ICTROPS

International Conference  
for Tropical Studies and Its Applications

Islamic Development Bank 4in1 Project  
Project Implementation Unit  
University of Mulawarman



IsDB  
البنك الإسلامي للتنمية  
Islamic Development Bank



The tourism potential of the natural resources in Muang Ilir Village is unfortunately not optimized and has not received serious attention from the surrounding community and local government to be developed into a tourist attraction in the form of an ecotourism village. This can be seen from the lack of people to promote the tourism potential in the area. In addition, the absence of the provision of facilities and infrastructure owned by local communities which usually encourages community participation and ensures access to physical resources is a stepping stone for the development of ecotourism villages.

In terms of the potential of Muang Ilir Village, it can be used as a reference for development into a local tourist attraction in the form of an ecotourism village. With the development and construction of tourism objects, it can directly open and increase job opportunities and local businesses for the people of Muang Ilir Village and improve the regional economy through community empowerment such as boat rentals for river crossings, sales of souvenirs for cuuk manik handicrafts, ticket guards, and sales of plantation products. . According to Hidayat (2016), community involvement in the development and management of tourism objects will have a positive impact on the sustainability and sustainability of the ecosystem around the object.

## Methodology

### Research Time and Place

The research was carried out in January-February 2021 in Muang Ilir Village, Lempake Village, North Samarinda District, Samarinda City, East Kalimantan.

### Data Collection Technique

The data needed in this study uses several techniques including the following:

#### Observation

Researchers carried out direct observations to the location to see the real condition and existence of Muang Ilir Village. Observations were made to see the natural potential both internally and externally as well as existing and unavailable facilities and infrastructure around the village.

#### Questionnaire

Researchers distributed questionnaires to the community around Muang Ilir Village. The questionnaire contains questions about community knowledge about the existence of the potentials that exist in the village, as well as suggestions relating to the development of the potential that exists in the village.

#### Interview

Researchers conducted interviews with the head of the Neighborhood Association, the people of Muang Ilir Village and environmental activists. Then the data and information in the interviews were used to find out the potential in the village. The strategy of developing an ecotourism village in Muang Ilir Village requires the role of the government and the surrounding community in order to realize local tourism that is of interest to the people of Samarinda and Indonesia.

## Documentation

Apart from interviews, distributing questionnaires and observations, data collection was also taken through the internet, journals, theses and theses as well as other materials related to this research. The documentation method aims to be evidence that the authors have carried out research through electronic and print media.

## Data Analysis Technique

The data collected is analyzed by formulating words and sentences that have been obtained in the field so that it can answer problems with original evidence based on the research studied. which is researched. The data were then classified according to the focus of the research that had answered all the questions in the problem formulation, in other words to solve and answer all the questions in our problem formulation using presentation techniques.

## Results and Discussion

### Strenght

Strength is the power source potential or other advantages in the area of ecotourism attractions Kampung Muang Ilir. The strength factors in the ecotourism object in Muang Ilir Village based on the results of questionnaires and interviews with the residents of Muang Ilir Village, which can be a strength to lift Muang Ilir Village into an ecotourism village are as follows:

### Natural Scenery



**Figure 3.1** Natural Scenery Muang Ilir Village  
Source: *Personal Documentation*

Muang ilir village has interesting natural scenery. Where, this is in line with the survey that has been carried out where for the attractiveness of natural scenery it reaches a percentage of 62.5%.

### Plants



**Figure 3.2** Plants Muang Ilir Village  
Source: *Personal Documentation*

In Muang Ilir Village have a high potential to make it an ecotourism potential. The people of Muang Ilir Village generally grow oranges, corn, and chilies. Besides, it has a special attraction for its fans, in line with the results of our survey which reached a percentage of 79.16%.

## River



**Figure 3.3** Karang Mumus River  
**Source: Personal Documentation**

The Karang Mumus River located in Muang Ilir Village has clear water color, with a variety of plants that live around it, so it has a well-maintained and diverse ecosystem. In addition, it also has a calm current so it is safe to use as a tourist attraction. This is in accordance with the survey results which state that the Karang Mumus River in Muang Ilir Village has a very high attractiveness with a percentage of 100%.

## Weakness

The weaknesses in Muang Ilir Village are the absence of public transportation and traffic signs leading to Kampung Muang Ilir so that tourists will find it difficult to get to Kampung Muang Ilir. The absence of public facilities such as public toilets or public bathrooms. Inadequate shelter or hut for a place to stop or rest while tourists.

## Opportunity

The opportunities that exist in the Kampung Muang Ilir area are ecotourism objects in Muang Ilir Village, such as river crossings, tree planting, Karang Mumus River School, and tree nurseries. This has the potential as a local tourism place that can attract local tourists and outside the city of Samarinda. Muang Ilir Village has potential in the economic aspect which has a large enough opportunity as a mainstay ecotourism village in the Samarinda City area which can increase the income of residents in Muang Ilir Village. Muang Ilir village has the potential to expand employment in the tourism sector as the economic development of the local community. For example, local people can open stalls *souvenir* or food shops that can empower the local community and increase the income of the local community.

## Threats

Threats of various activities that can damage the environment. Such as littering, illegal logging, taking fish with tiger trawlers. Threats of natural disasters such as floods and land fires.

## Community Opinion Regarding Muang Ilir Village Becoming an Ecotourism Village

One way to gain success in developing an area into ecotourism is to involve the local community in all activities to support this development. Therefore, from our *survey* and interviews with the people of Muang Ilir Village,

100% of the people support the development of Muang Ilir Village into an ecotourism village.  
Promotive Aspects That Need To Be Done

### Graph of knowledge of the people of Samarinda towards Muang Ilir Village

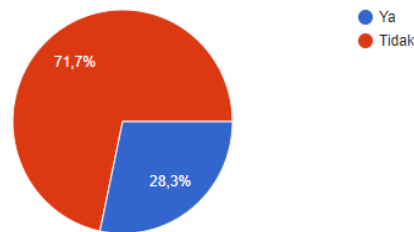

**Figure 3.4** Knowledge of the Samarinda Community towards Muang Ilir Village

From these results, 38 out of 53 people or 71.7% still do not know about the existence of Muang Ilir Village. From this it can be seen that the community is more familiar with the Lempake or Benanga area and does not know Muang Ilir Village. This is one of the strong reasons for the need for promotions related to Muang Ilir Village.

### Graph of Samarinda people who have visited Muang Ilir Village

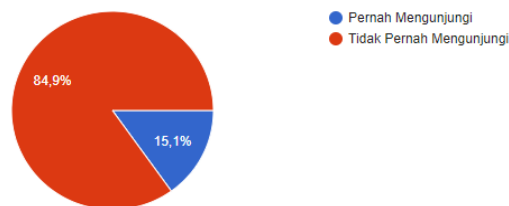

**Figure 3.5** Samarinda people who have visited Muang Ilir Village

*Platforms digital* has a very big role to strengthen the promotive aspect of the ecotourism village in Muang Ilir Village. Along with the development of technology, promotions can use new media, namely social media as a way to promote Muang Ilir Village as an ecotourism village. Promotion through social media can increase community economic empowerment because it can create business opportunities, such as through *Facebook, Twitter, Instagram, WhatsApp, Youtube*, and other social media (Nurjannah, 2018: 40).  
Strategy for Development of Muang Ilir Village to Become an Ecotourism Village

#### Intensive Utilization Block

This block is used intensively for ecotourism village in Muang Ilir Village. The area include rice fields and vacant land around residential areas.

#### Core Zone

Improvement of road access. In Muang Ilir Village, it is necessary to improve the road at the entry point for rice fields, plantations, and access to the Karang Mumus River.

Levy and parking. In addition to making it easier for tourists to place their vehicles on a regular basis, the existence of a levy from parking that is carried out can increase regional income.

Availability of transportation facilities. With the existence of transportation facilities such as public transportation or online motorcycle taxis, it will certainly make it easier for tourists who come without a personal vehicle.

Facilities such as public toilets are needed when building a place as a tourist area. The existence of a trash can can maintain the cleanliness and beauty of Muang Ilir Village. Shelters or huts can be used for tourists who visit as a place to rest or a gathering point when a tourism education program will be held. Traveling activities that take a long time result in the need for strategic and clean places of worship. The availability of information posts is very much needed in Muang Ilir Village.

### Support Zone

People of Muang Ilir Village, especially mothers, have the ability to make beaded crafts that can be traded to visitors as *souvenirs* so that community empowerment can occur.

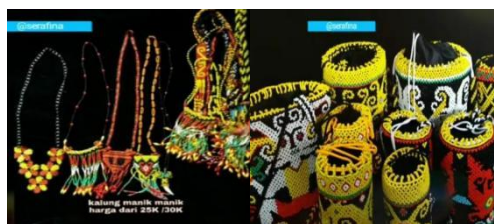

**Figure 4.6** Cucuk Manik Crafts

Source : <https://youtu.be/Of2EqTVNzK0>

Typical local culinary. Kolang Kaling that are widely available in Muang Ilir Village can be used as special preparations that benefit the surrounding community. Minapadi processing utilizes local wisdom that already exists in an area, by utilizing elements that exist in nature. In addition to land suitability, irrigation networks are an important factor influencing the success of the Minapadi system (Lestari, 2017: 71). Rice field bridge. Tourists visiting the ecotourism village in Muang Ilir Village can enjoy the natural beauty of rice fields by using a rice fields bridge and can be used as a contemporary photo object. Vegetable museum. The existence of vacant land that has not been utilized can be developed into a vegetable museum. This can attract the attention of tourists because it is not yet available in Samarinda City.

### Limited Utilization Block

Activities that can be carried out in this block include special interest tourism for research purpose.

### Protection Block

This block is a flora and fauna conservation area. Covers the river area and the Karang Mumus riverbank.

### The Effect of Development on the Community Economy of the Muang Ilir Village

The decline in economic development caused by Covid-19 has had a major impact on the people of Indonesia, including those in the Muang Ilir Village area, Samarinda. Based on a survey conducted on the people of Kampung Muang Ilir, there were 91.66% of the people of Kampung Muang Ilir who agreed that the Covid-19 pandemic had an impact on the economy which caused an economic decline. Therefore, the author again asks for the opinion of the people of Kampung Muang Ilir regarding the existence of an ecotourism village as a step to restore the economic productivity of the people of Kampung Muang Ilir. The author conducted a survey related to the provision of local economic businesses in the ecotourism sector, where at the point the existence of an ecotourism village would increase job opportunities, increase business opportunities for local residents and small entrepreneurs, increase business capital ownership, and improve the skills of local communities getting 100% support from the community. Muang Ilir village.

The author also conducted a survey through an online questionnaire distributed to the people of Samarinda City on Muang Ilir Village as an ecotourism village in Samarinda. The results of the survey we conducted are as follows:

#### Graph of the interest of the people of Samarinda to visit Muang Ilir Village when it became an ecotourism village in Samarinda

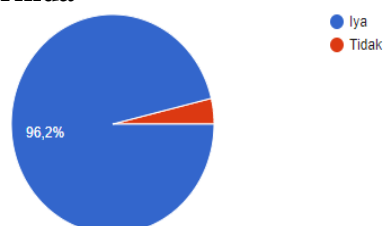

**Figure 4.7** Interest of the Samarinda Community to Visit Muang Ilir Village

From these results, 51 out of 53 people or 96.2% of the Samarinda community were interested in visiting Muang Ilir Village when it became an ecotourism village in Samarinda.

#### The graph of the interest of the people of Samarinda to buy products produced by the people of Kampung Muang Ilir when they became an ecotourism village in Samarinda

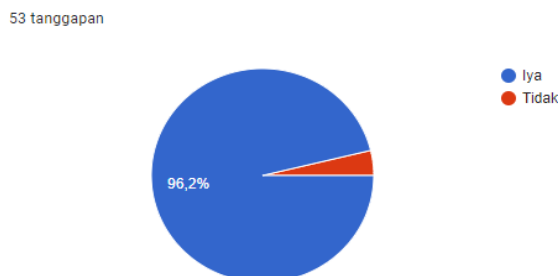

**Figure 4.8** Interest of the Samarinda Community to Buy Products

From these results, 51 out of 53 people or 96.2% of the people of Samarinda are interested in buying products produced by the people of Kampung Muang Ilir when they became an ecotourism village in Samarinda. With the presence of an ecotourism village in Muang Ilir Village, it is hoped that it can be a step to restore, stabilize, and improve the economic conditions of the people in Muang Ilir Village, Samarinda.

## Conclusions

The potential of Muang Ilir Village which is a supporting factor to be developed into an ecotourism village is that it has very attractive natural scenery, plants and rivers and is supported by people who have local wisdom. The strategy for developing Muang Ilir Village into an ecotourism village can be done by dividing the area into three blocks, namely an intensive use block consisting of a core zone covering infrastructure improvements and a supporting zone including souvenir stalls to sell community handicrafts, local culinary specialties, rice cakes, bridges, rice fields and vegetable museum. Limited utilization blocks in the form of nurseries for tourism with research purposes. The protection block covers the river area and its surroundings as an educational-based river excursion and tree planting with the Karang Mumus River School. The development of an ecotourism village supports increasing regional economic productivity in Muang Ilir Village. This is based on the survey results of 100% that the community believes that this development can increase employment so that it helps improve the economy and is strengthened by the survey results of 96.2% of Samarinda people interested in visiting and buying products traded in Muang Ilir Village.

## REFERENCES

- Arida, INS (2017). *Ecotourism: Development, Local Participation, and Challenges of Ecotourism*. PRESS CACRA. Denpasar.
- Fahrika, AI, & Juliansyah R. (2020). The Impact of the Covid 19 Pandemic on Macroeconomic Developments in Indonesia and the Policy Response Taken. *INOVASI Journal*, 16(2), 207 & 209.
- Harahap, EF (2012). Community Empowerment in the Economic Sector to Realize a Strong and Independent National Economy. *Journal of Management and Entrepreneurship*. 3(2), 78-79 & 82-83.
- Hidayat, S. (2016). Ecotourism Development Strategy in Kinarum Village, Tabalong Regency. *Journal of Tropical Forests*, 4(3), 285.
- Lestari, S., & Aziz NB (2017). Implementation of Minapadi in the Framework of Supporting Food Security and Improving Community Welfare. *Proceedings of Biology Education Conference*, 14(1), 71.
- Luthfia, AR (2013). Observing the Urgency of the Village in the Era of Regional Autonomy. *Journal of Rural and Development*, 4(2), 136.
- Maulana, A., & Chamma FPPK (2020). Seasonal Patterns of Foreign Tourist Visits to Bali. *Indonesian Tourism Journal*, 14(2), 74.
- Murdani., et al. (2019). Community Economic Development Through Empowerment of Micro, Small and Medium Enterprises (Study in Kandri Village, Gunungpati District, Semarang City). *ABDIMAS Journal*, 23(2), 154-155.
- Tisnawati, E., et al. (2019). Community-Based Eco-Tourism Development Strategy in Rejowinangun Tourism Village. *INNERSIA Journal*, 15(1), 3.



## TCBD-431

# Microteaching for Pre-service Science Teachers during the COVID-19 Pandemic: A Theoretical Framework

Zeni Haryanto<sup>1\*</sup>, Nurul Fitriyah Sulaeman<sup>1</sup>, Atin Nuryadin<sup>1,2</sup>, Pramudya D.A. Putra<sup>3</sup> Shafira  
Aulia Putri<sup>1</sup>, Annisa Zahra Rahmawati<sup>1</sup>

<sup>1</sup>Physics Education Program, Mulawarman University

<sup>2</sup>Graduate School of Sciences and Technology for Innovation, Yamaguchi University

<sup>3</sup>Science Education Program, University of Jember

### Abstract

Teaching has a unique complexity that intertwines the ability to deliver information and the information itself. While the terminology of teaching is specifically used for teachers, developing teaching ability is well-known through microteaching classes for pre-service teachers that were initially conducted at Stanford University in 1966. On the other hand, the COVID-19 pandemic forces the pre-service science teacher program to switch from face-to-face to an online system. Therefore, the specific framework of microteaching for pre-service science teachers as an adaptation to the need of online teaching is essential to be explored deeper. Our research conducted a literature review on articles in various educational databases, journals, and books. This paper outlines the coherence in microteaching during the pandemic, TPACK for pre-service science teachers, and a conceptual framework for microteaching for pre-service science teachers during the pandemic.

**Keywords:** Microteaching, Pre-service Science Teacher, Theoretical Framework

### Introduction

Since the well-known sentence "The one who can, does; he who cannot teach" has been clarified, there is a constant need to ensure teacher professional knowledge (Shulman, 1986). This central issue was also growing in line with the transformation of teacher knowledge, especially its relationship with technology (Fransson & Holmberg, 2012). This concern also emphasizes that the pre-service teacher program needs to focus on developing the knowledge and skills to prepare future teachers. Earlier with this concern, a pre-service teacher program has developed a course called "microteaching" (Fortune et al., 1967). The relation between developing essential skills for pre-service teachers and microteaching courses became a central issue (Arsal, 2014; Diana, 2013; Onwuagboke et al., 2017). Microteaching activity provides the opportunity for the pre-service teachers to transform their knowledge into a mini teaching experience.

The development of technological-pedagogical-content-knowledge (TPACK) consists of three single domains: technological knowledge, content knowledge, and pedagogical knowledge (Mishra & Koehler, 2008). The uniqueness of content plays one of the important elements. The development of TPACK in pre-service science teachers is essential to explore (Efwinda & Mannan, 2021a) due to the nature of science itself (Bayram-Jacobs et al., 2019). Unfortunately, in the specific science content such as energy, content knowledge of pre-service science teachers is not satisfied (Putra & Kumano, 2018).



the 5<sup>th</sup> **ICTROPS**

International Conference  
for Tropical Studies and Its Applications

Islamic Development Bank 4in1 Project  
Project Implementation Unit  
University of Mulawarman



IsDB  
البنك الإسلامي للتنمية  
Islamic Development Bank



During the COVID-19 pandemic, reflection on the urgent need to emphasize the technological knowledge supporting science teachers strongly appears (Campbell et al., 2021; Reiss, 2020). Theoretical frameworks are critically important to all research, especially in science education, to justify the importance and significance of the work (Lederman & Lederman, 2015). This study investigates the framework of microteaching for pre-service science teachers during the COVID-19 pandemic. The framework is beneficial to direct the microteaching course in line with the knowledge and skills during the online classroom that is essential for the pre-service science teacher.

## Methodology

Literature about microteaching was Qualitative-Philosophical (QualPhil). This literature was studied to develop a theoretical framework of microteaching for pre-service science teachers during the COVID-19 Pandemic. QualPhil is a pragmatism-grounded approach that blends qualitative and philosophical research approaches (Mpofu, 2019). The knowledge on microteaching was drawn from different sources and perspectives in literature, and ongoing research works. Finally, the framework model was developed by linking main categories (themes).

## Results and Discussion

### Seeking coherence in microteaching during COVID-19 pandemic

Much ambiguity still surrounds microteaching, its adaptation and implementation during the pandemic. Generally, microteaching is a course that is supposed to be taken by pre-service teachers in the third year of their four-year program. The course is taken after the pre-service teachers complete their pedagogy and content courses. Since it was introduced at Stanford University in 1963 (Fortune et al., 1967), microteaching is a compulsory course that scales down the total classroom teaching activity complexity. In microteaching, the duration is shorter, and the number of students is reduced. The pre-service teachers take turns to be a teacher and students. Microteaching aims to identify teaching behaviour as observable skills and the development and measurement of appraisal instruments (Spelman & St. John-Brooks, 1972). The teaching skills develop continuously with the needs of modern education. In this fast-changing world, the roles and expectancies of teachers are constantly evolving as they face the challenges of new skills requirements, technological developments, individualized teaching, special learning needs, and increasing social and cultural diversity (Peng et al., 2014).

The critical stages of microteaching are planning, implementation, and reflection (Elias, 2018; Kilic, 2010). The reflection stage is less utilized even though it is identified as a crucial stage (Karlström & Hamza, 2019). On the other hand, the COVID-19 pandemic forces to shift the microteaching class from traditional to online. The utilization of video becomes commonly used during microteaching. Additional skills are required for the pre-service teacher to conduct the online microteaching classroom.

### TPACK for pre-service science teachers

Teachers are entrusted with more than just comprehending the links between content and pedagogy as technology continues to permeate educational institutions and surroundings (Swallow & Olofson, 2017). There are three fundamental components at the heart of successful technology-enhanced teaching: content, pedagogy, and technology, as well as the interactions within and between them. The interactions between and among the



the 5<sup>th</sup> ICTROPS

International Conference  
for Tropical Studies and Its Applications

Islamic Development Bank 4in1 Project  
Project Implementation Unit  
University of Mulawarman



IsDB  
البنك الإسلامي للتنمية  
Islamic Development Bank



three components, which play out differently in different situations, explain the significant differences in the degree and quality of educational technology integration seen (Koehler & Mishra, 2009). The TPACK framework extends Shulman's definitions of PCK to describe how instructors' understanding of educational technologies and PCK interact with one another to generate successful technology-assisted instruction (Efwinda & Mannan, 2021; Koehler & Mishra, 2009; Mishra, 2019). However, while the TPACK hypothesis is intriguing, additional research into the link between these areas is required before the curriculum is redeveloped (Archambault & Barnett, 2010). Researchers concentrating on the framework's theoretical underpinnings have focused on whether the overlapping components of knowledge in the framework are better characterized as integrative, where the domains of knowledge in the TPACK framework are separate or transformational (Rosenberg & Koehler, 2015).

There are three main components of teachers' knowledge: content, pedagogy, and technology. Equally important to the model are the interactions between and among these bodies of knowledge, represented as PCK, TCK (technological content knowledge), TPK (technological pedagogical knowledge), and TPACK (Koehler & Mishra, 2009). Teachers' content knowledge (CK) is their understanding of the subject matter to be learnt or taught (Koehler & Mishra, 2009). The information provided in middle school science differs from the stuff covered in an undergraduate astrophysics course. Therefore teachers must be well-versed in their subject matter. Pedagogical knowledge (PK) refers to instructors' in-depth understanding of the processes and practices or strategies of teaching and learning. Understanding how students learn, basic classroom management abilities, lesson preparation, and student evaluation are all examples of generic knowledge (Koehler & Mishra, 2009). Acquiring technological knowledge (TK) enables a person to do a wide range of activities utilizing information technology and devise novel approaches to completing a particular work. This view of TK does not postulate an "end state" but rather views it growing across a lifetime of creative, open-ended engagement with technology (Koehler & Mishra, 2009). The other three cores combined result in four additional knowledges. The knowledge about specific teaching practices that appropriately fit the nature of particular subject content is known as pedagogical content knowledge (PCK). Technological pedagogical knowledge (TPK) is the knowledge about standard technologies' existence, components, and capabilities that could be appropriately used to support teaching and learning processes and practices. The understanding of how genuine subject matter knowledge may be transformed into suitable representations via standard technologies is known as technical content knowledge (TCK). The most integrated one is the knowledge about how the transactional relationship between knowledge about the content (C), pedagogy (P), and technology (T) was dynamic in order to develop appropriate, context-specific strategies and representations for better learning of content knowledge (TPACK) (Srisawasdi, 2012). Moreover, science has a specific framework to follow. The scientific framework consists of content knowledge, procedural knowledge, and epistemic knowledge (OECD, 2019). Therefore, the content of science plays a unique role to build TPACK in pre-service science teachers.

To adapt the digitalization, teachers must integrate technology into their classroom instruction to prepare students for a digitalized future. As a result, it is commonly suggested that pre-service teachers should obtain subject-specific professional expertise about technology integration to assist the learning of their future students (Lachner et al., 2021). It only makes sense that pre-service teachers are demanded to have TPACK skills (Turmuzi & Kurniawan, 2021). Pre-service teachers with strong TPACK abilities have a better probability of completing their programs and becoming well-polished instructors who can understand their subject matter extensively and thoroughly (Koyuncuoglu, 2021; Santika et al., 2021).

## The conceptual framework for microteaching for pre-service science teachers during the COVID-19 pandemic

Our framework proposes that online microteaching needs to preserve the three core stages of traditional microteaching: plan, teaching, and reflection. We presented the need to clarify the TPACK components written in the lesson plan measured by the Guttman scale (1 = observable and 0 = not observable). The group reflection of the lesson plan opens the opportunities to share and discuss among a small group of pre-service science teachers. After the reflection, they may revise their lesson plan if it is needed. The implementation stage is an online microteaching classroom with a duration between 15 – 25 minutes. The teaching videos became the main source of the second reflection stage. After having experience of planning, reflection and teaching implementation, the TPACK components that showed through the video should be observable through more specific level. We proposed Likert scale could be used in the video observation sheet.

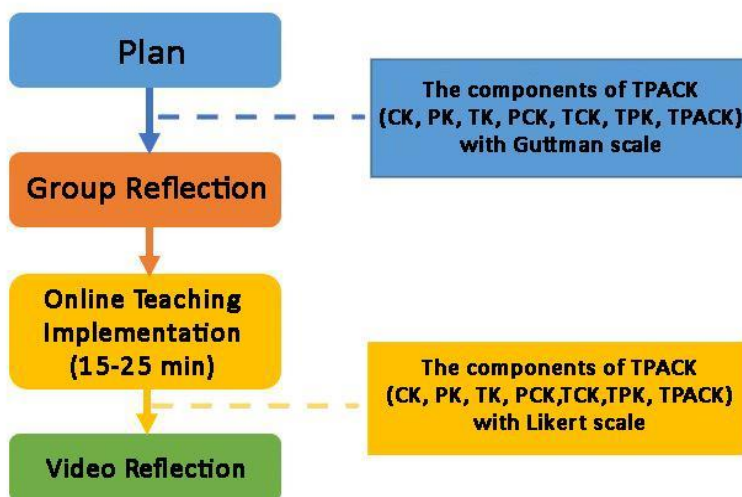

**Figure 1.** Conceptual Framework of Microteaching beyond Pandemic

## Conclusions

Our framework proposes that online microteaching for pre-service science teachers consists of 4 main stages: planning, group reflection, online science teaching implementation, and video-based reflection. We proposed the need to clarify the TPACK components written in the lesson plan measured by the Guttman scale. Moreover, the TPACK components that showed through the video should be observable through the Likert scale.

## ACKNOWLEDGEMENT

The work described in this article was fully supported by a research grant from PIU IsDB Mulawarman University, Indonesia (Grand number 405/UN17.11/PL/2021).



the 5<sup>th</sup> **ICTROPS**  
International Conference  
for Tropical Studies and Its Applications

Islamic Development Bank 4in1 Project  
Project Implementation Unit  
University of Mulawarman



IsDB  
البنك الإسلامي للتنمية  
Islamic Development Bank



## REFERENCES

- Archambault, L. M., & Barnett, J. H. (2010). Revisiting technological pedagogical content knowledge: Exploring the TPACK framework. *Computers and Education*, 55(4), 1656–1662. <https://doi.org/10.1016/j.compedu.2010.07.009>
- Arsal, Z. (2014). Microteaching and pre-service teachers' sense of self-efficacy in teaching. *European Journal of Teacher Education*, 37(4), 453–464. <https://doi.org/10.1080/02619768.2014.912627>
- Bayram-Jacobs, D., Henze, I., Evagorou, M., Shwartz, Y., Aschim, E. L., Alcaraz-Dominguez, S., Barajas, M., & Dagan, E. (2019). Science teachers' pedagogical content knowledge development during enactment of socioscientific curriculum materials. *Journal of Research in Science Teaching*, 56(9), 1207–1233. <https://doi.org/10.1002/tea.21550>
- Campbell, T., Melville, W., Verma, G., & Park, B. Y. (2021). On the Cusp of Profound Change: Science Teacher Education in and Beyond the Pandemic. *Journal of Science Teacher Education*, 32(1), 1–6. <https://doi.org/10.1080/1046560X.2020.1857065>
- Diana, T. J. (2013). Microteaching Revisited: Using Technology to Enhance the Professional Development of Pre-Service Teachers. *The Clearing House: A Journal of Educational Strategies, Issues and Ideas*, 86(4), 150–154. <https://doi.org/10.1080/00098655.2013.790307>
- Efwindi, S., & Mannan, M. N. (2021). Technological pedagogical and content knowledge (TPACK) of prospective physics teachers in distance learning: Self-perception and video observation. *Journal of Physics: Conference Series*, 1806(1). <https://doi.org/10.1088/1742-6596/1806/1/012040>
- Elias, S. K. (2018). Pre-Service Teachers' Approaches to the Effectiveness of Micro-Teaching in Teaching Practice Programs. *Open Journal of Social Sciences*, 06(05), 205–224. <https://doi.org/10.4236/jss.2018.65016>
- Fortune, J. C., Cooper, J. M., & Allen, D. W. (1967). The Stanford Summer Micro-Teaching Clinic, 1965. *Journal of Teacher Education*, 18(4), 389–393. <https://doi.org/10.1177/002248716701800402>
- Fransson, G., & Holmberg, J. (2012). Understanding the Theoretical Framework of Technological Pedagogical Content Knowledge: A collaborative self-study to understand teaching practice and aspects of knowledge. *Studying Teacher Education*, 8(2), 193–204. <https://doi.org/10.1080/17425964.2012.692994>
- Karlström, M., & Hamza, K. (2019). Preservice Science Teachers' Opportunities for Learning Through Reflection When Planning a Microteaching Unit. *Journal of Science Teacher Education*, 30(1), 44–62. <https://doi.org/10.1080/1046560X.2018.1531345>
- Kilic, A. (2010). Learner-Centered Micro Teaching in Teacher Education. *International Journal of Instruction*, 3(1), 77–100.
- Koehler, M. J., & Mishra, P. (2009). What is technological pedagogical content knowledge? *Contemporary Issues in Technology and Teacher Education* (Vol. 9, Issue 1). <http://www.tpck.org/>.
- Koyuncuoglu, Ö. (2021). An investigation of graduate students' technological pedagogical and content knowledge (tpack). *International Journal of Education in Mathematics, Science and Technology*, 9(2), 299–313. <https://doi.org/10.46328/IJEMST.1446>
- Lachner, A., Fabian, A., Franke, U., Preiß, J., Jacob, L., Führer, C., Küchler, U., Paravicini, W., Randler, C., & Thomas, P. (2021). Fostering pre-service teachers' technological pedagogical content knowledge (TPACK): A quasi-experimental field study. *Computers and Education*, 174. <https://doi.org/10.1016/j.compedu.2021.104304>
- Lederman, N. G., & Lederman, J. S. (2015). What Is A Theoretical Framework? A Practical Answer. *Journal of Science Teacher Education*, 26(7), 593–597. <https://doi.org/10.1007/s10972-015-9443-2>



the 5<sup>th</sup> ICTROPS

International Conference  
for Tropical Studies and Its Applications

Islamic Development Bank 4in1 Project  
Project Implementation Unit  
University of Mulawarman



IsDB  
البنك الإسلامي للتنمية  
Islamic Development Bank



- Mishra, P. (2019). Considering Contextual Knowledge: The TPACK Diagram Gets an Upgrade. In *Journal of Digital Learning in Teacher Education* (Vol. 35, Issue 2, pp. 76–78). Routledge. <https://doi.org/10.1080/21532974.2019.1588611>
- Mishra, P., & Koehler, M. J. (2008). Introducing Technological Pedagogical Content Knowledge. Paper Presented at the Annual Meeting of the American Educational Research Association, 1–16.
- Mpofu, V. (2019). A Theoretical Framework for Implementing STEM Education. In *Theorizing STEM Education in the 21st* (Vol. 1, p. 13). InetchOpen.
- OECD. (2019). PISA 2018 Assessment and Analytical Framework. OECD Publishing.
- Onwuagboke, B. B. C., Osuala, R. C., & Nzeako, R. C. (2017). The Impact of Microteaching in Developing Teaching Skills among Pre-Service Teachers in Alvan Ikoku College of Education Owerri, Nigeria. *African Research Review*, 11(2), 237. <https://doi.org/10.4314/afrrrev.v11i2.18>
- Peng, W. J., McNess, E., Thomas, S., Wu, X. R., Zhang, C., Li, J. Z., & Tian, H. S. (2014). Emerging perceptions of teacher quality and teacher development in China. *International Journal of Educational Development*, 34(1), 77–89. <https://doi.org/10.1016/j.ijedudev.2013.04.005>
- Putra, P. D. A., & Kumano, Y. (2018). Energy Learning Progression and STEM Conceptualization Among Pre-service Science Teachers in Japan and Indonesia. *New Educational Review*, 53(3), 153–162. <https://doi.org/10.15804/ner.2018.53.3.04>
- Reiss, M. J. (2020). Science Education in the Light of COVID-19. *Science & Education*, 29(4), 1079–1092. <https://doi.org/10.1007/s11191-020-00143-5>
- Rosenberg, J. M., & Koehler, M. J. (2015). Context and technological pedagogical content knowledge (TPACK): A systematic review. *Journal of Research on Technology in Education*, 47(3), 186–210. <https://doi.org/10.1080/15391523.2015.1052663>
- Santika, V., Indriayu, M., & Sangka, K. B. (2021). Investigating of the Relations among TPACK Components of Economic Teacher Candidates in Sebelas Maret University (UNS) in 2020: A Structural Equation Modeling. *IOP Conference Series: Earth and Environmental Science*, 1808(1). <https://doi.org/10.1088/1742-6596/1808/1/012029>
- Shulman, L. (1986). Those who Understand: Knowledge Growth in Teaching. *Journal of Education*, 193(3), 1–11. <https://doi.org/10.1177/002205741319300302>
- Spelman, B. J., & St. John-Brooks, C. (1972). Microteaching and Teacher Education: A Critical Reappraisal. *The Irish Journal of Education / Iris Eireannach an Oideachais*, 6(2), 73–92. <http://www.jstor.org/stable/30077201>
- Srisawasdi, N. (2012). The Role of TPACK in Physics Classroom: Case Studies of Preservice Physics Teachers. *Procedia - Social and Behavioral Sciences*, 46, 3235–3243. <https://doi.org/10.1016/j.sbspro.2012.06.043>
- Swallow, M. J. C., & Olofson, M. W. (2017). Contextual Understandings in the TPACK Framework. *Journal of Research on Technology in Education*, 49(3–4), 228–244. <https://doi.org/10.1080/15391523.2017.1347537>
- Turmuzy, M., & Kurniawan, E. (2021). Kemampuan Mengajar Mahasiswa Calon Guru Matematika Ditinjau dari Technological Pedagogical and Content Knowledge (TPACK) pada Mata Kuliah Micro Teaching. *Jurnal Cendekia: Jurnal Pendidikan Matematika*, 05(03), 2484–2598.

## TCBD-483

# Computational Intelligent Algorithms in Multi-Sensor Data Fusion for UAV Detection and Identification: Challenges and Opportunities

**Risa Farrid Christianti<sup>1\*</sup>, Azhari S.N.<sup>2</sup>**

<sup>1</sup>Faculty of Telecommunication and Electrical Engineering, Institut Teknologi Telkom Purwokerto

<sup>2</sup>Department of Computer Science and Electronics, Gadjah Mada University

*Corresponding Author\*: risa@ittelkom-pwt.ac.id*

### Abstract

Nowadays, counter-Unmanned Aerial Vehicle (c-UAV) applications include multisensory devices, such as electro-optical, thermal, acoustic, radar and radio frequency sensors, the data of which can be combined to increase confidence in hazard identification. Object identification, classification, multi-object tracking, and multisensory information fusion are just a few of the complex challenges that occur as a result. In recent years, researchers have made significant progress using deep learning-based approaches to accomplish similar tasks for generic objects, but using deep learning for UAV detection and classification is a new idea. Consequently, there is a need to offer an overview of deep learning technologies applied to c-UAV related tasks using multisensor data. The significant increase in the number of articles on "c-UAV systems" in recent years shows that research in this area still has enormous opportunities. This paper aims to describe improvements in deep learning on c-UAV-related tasks when applied to data from multiple sensors and multisensor information fusion and make recommendations for using deep learning algorithms in UAV detection and identification.

**Keywords:** UAV; Multisensor Data Fusion; Deep Learning; UAV detection; UAV identification.

### Introduction

Unmanned Aerial Vehicles (UAV), or as they are often referred to unmanned vehicles, are used by government authorities for tasks from border security, law enforcement, surveillance area, and forest fire surveillance to commercial-related studies used by civilians such as construction, agriculture, insurance, internet communications, and general cinematography. A recent advance is the counter UAV (c-UAV) system, which offers a system (Prime Consulting & Technologies, 2015) consisting of multisensor weaponry to maintain situational awareness and protect critical infrastructure or critical events. This application includes several integrated sensors for detecting threats, mainly through radar or electro-optical/thermal (EO-IR) sensors and less often through acoustic and radio frequency (RF) sensors.

However, the rapid deployment of UAVs poses serious security concerns. In recent years, newspapers and mass media have reported dozens of incidents involving UAVs flying in restricted areas and around critical infrastructure or public events. Research efforts on UAV detection and classification methods based on deep learning using radar, electro-optical, thermal, and acoustic sensors, as well as multisensor information fusion algorithms, have been thoroughly reviewed. Research on c-UAV systems is an emerging field, and the addition of deep learning could lead to breakthrough in the years to come.

A considerable drawback in multisensor C-UAV applications is that the information from the different sensors is not combined to get the results. However, the warning signals are used independently of each system component to provide some initial warning which the human operator then confirms. For example, early detection emanating from a radar sensor is then confirmed by an operator looking in this direction via optical cameras. The latest advances in data fusion techniques can fully automate without a substantial trade-off in classification capabilities. Data fusion techniques have garnered significant attention in recent years, mainly because of the importance of combining information from different types of sensors for various applications (Liggins, Hall, & Llinas, 2009). The scope of the data pooling target is to achieve more accurate results than those from a single sensor while compensating for each other's weaknesses.

On the other hand, artificial intelligence and deep neural networks (DNN) have become desirable methodologies for data representation (Zhao, Zheng, Xu, & Wu, 2019). DNN is used to process various kinds of data from multiple sources because of its ability to find high-level and abstract features that feature extraction methods cannot. Therefore, the use of deep learning methods in data fusion can be significant in overcoming the critical problem of multisensor data aggregation (Samaras et al., 2019).

One of the foundations of current information technology is sensor technology. Sensors play a crucial role in data fusion systems and are an essential component of them. Function, structure, and other factors can be used to represent data fusion. The functional model is the most important from the standpoint of the data fusion process. It explains the data fusion system's critical operations as well as its subsystems. It outlines the basic procedures of the data fusion system and its subsystems, the database's role, and how the system's components interact. The structural model explains the data fusion system and the information interaction process between the design and the external environment from a data flow perspective (Chang & Ko, 2014) (Yu, 2017). Figure 1 depicts the multisensor data fusion system's functioning model (Ma, Zhang, Wang, & Zhang, 2018).

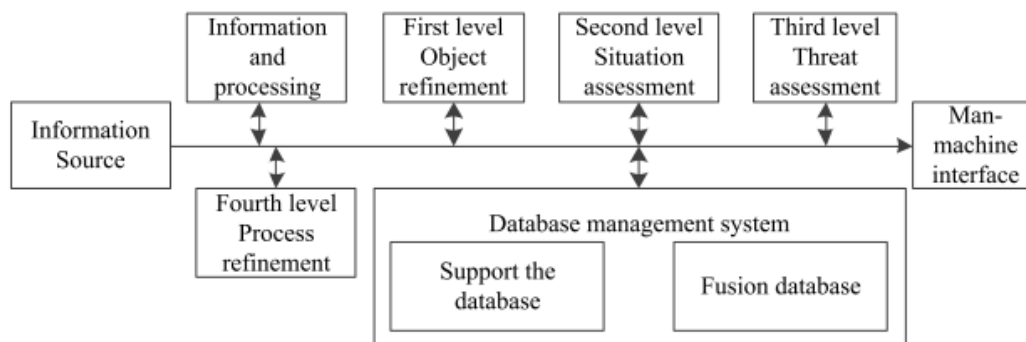

**Figure 1. The functional model of multisensor fusion system (Ma et al., 2018)**

Data fusion systems are frequently complicated mixes of sensing devices, processing, and fusion algorithms. This paper provides an overview of the basic principles in data fusion architecture, both from a hardware and algorithm standpoint. The essential difficulties of sensing, estimation, and perceiving are addressed through data fusion applications in robotics. Multisensory data merger is a technique for combining data from multiple sources to create a cohesive image. Sensor networks, robotics, video and image processing, and intelligent





the 5<sup>th</sup> ICTROPS

International Conference  
for Tropical Studies and Its Applications

Islamic Development Bank 4in1 Project  
Project Implementation Unit  
University of Mulawarman



IsDB  
البنك الإسلامي للتنمية  
Islamic Development Bank



system design are just a few domains where data fusion systems are frequently used. Because data fusion is such a vast topic, numerous phrases have been thrown around. This ad hoc terminology and approaches across various sciences, including engineering, management, and a variety of other publications, demonstrate that the same idea has been investigated numerous times. In recent years, the data fusion research community has made significant progress. The flawless emulation of the human brain's data fusion potential, on the other hand, is still a long way off (Durrant-whyte & Henderson, 2008). This paper aims to describe improvements in deep learning on c-UAV-related tasks when applied to data from multiple sensors and multisensor information fusion and make recommendations for using deep learning algorithms in UAV detection and identification.

## Methodology

The description of this research process must be backed up with references for the explanation to be scientifically acknowledged. In 2004, research on UAV sensor data fusion algorithms began, which has since been published in many scholarly journals (Mahler, 2004). Meanwhile, in 2009 researchers began investigating UAV detection using multisensor data fusion techniques (Yi & Min, 2009).

### Kalman Filters + Multi-Layer Perceptron (MLP)

One of the multisensor data fusion methods is Safari et al. (Safari, Shabani, & Simon, 2014). In this paper, data fusion problems for asynchronous, multirate, and multisensor linear systems are studied. Several sensor systems observe the linear system, each having a different sampling rate. Assuming that the state-space model is known at the highest time resolution of sensor system scale and a known mathematical relationship between sampling rates, a comprehensive state-space model covering all sensor systems is presented. The state vector is estimated by a neural network that combines the outputs of several Kalman filters, one filter for each sensor system. State approximation proved to perform better than other data fusion approaches due to the new neural network-based sensor fusion approach.

Figure 2 depicts the MLP, in which  $N$  Kalman filters are used, one for each sample rate. As demonstrated in, each Kalman filter produces  $M$  state estimates. These  $MN$  estimations are sent to a set of hidden neurons through the MLP, with the number of hidden neurons specified by the designer as a tuning parameter. The output neuron receives the hidden neurons' outputs, and the MLP's output is the fused state estimate based on the highest sampling rate.

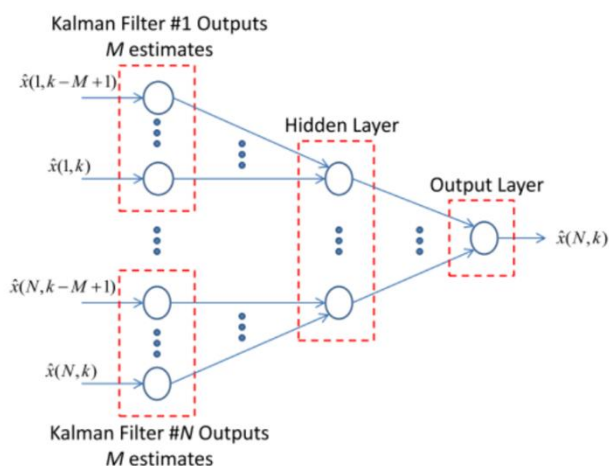

**Figure 2. Multilayer perceptron for fusing Kalman filter estimates. There are N sensor systems in this figure, and thus N sets of Kalman filter estimate. Each set of Kalman filter estimates includes M estimates. This MLP has MN inputs, a user-determined number of hidden neurons, and one output.**

### Clustering Algorithm

This algorithm presents a new hybrid algorithm for clustering and cluster member selection in a wireless multisensor system. After the passage of the cluster head and member nodes, a data fusion technique is proposed to partition and process the data. The proposed scheme efficiently reduces blind broadcast messages but also reduces signal overhead due to cluster formation. Furthermore, routing techniques are provided based on the layered architecture. The proposed layered architecture efficiently minimizes the routing path to the base station. A comprehensive analysis was carried out on the proposed scheme with advanced centralized and distributed clustering techniques. These results show that the proposed system outperforms competitive algorithms in terms of energy consumption, packet loss, and cluster(x) formation (DIn, Ahmad, Paul, Ullah Rathore, & Jeon, 2017).

In the clustering technique, a set of devices are grouped in a geographic area. After grouping, the cluster head is selected based on specific algorithms, where the selected node is called the cluster head, while the other nodes are called member nodes. The cluster head obtains data from its member nodes and combines them. It then forwards the data to the neighboring cluster heads at the base station via direct hop or multi-hop. The routing data in the cluster is divided into two broad categories, namely intra-cluster (within the same group) and inter-cluster (within the set) data transmission. Such a cluster layout reduces a large amount of energy in the network. Wireless ad-hoc and sensor networks consist of hundreds or even thousands of nodes that communicate with each other. Nature is so densely networked, consumes more energy in exchanging data, with unstable additive loads and fatal errors.

After the formation of the cluster, then we have to process the Big Data received by the cluster head. The

proposed architecture is based on data fusion, which was initially developed by the Director of the US Joint Laboratory (JDL) and the US Department of Defence (DoD) (Sorsa, Koivo, & Koivisto, 1991). The researcher has modified and changed the existing data fusion techniques according to the scheme based on the architectural requirements. The block diagram of data fusion in a multisensor system is illustrated in figure 3.

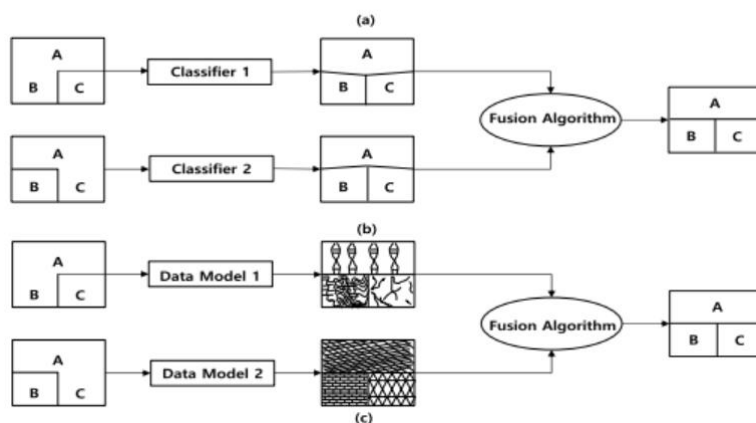

**Figure 3. Block diagram of data fusion modeling (DIn et al., 2017)**

### Brooks-Iyengar Algorithm

This algorithm is proposed to understand and describe multiple sensors to measure various aspects of the physical world. In addition, we will discuss a new technique of using the Brooks-Iyengar algorithm in designing a system that will decentralize the data source of the appropriate measurement and thereby ensure the integrity of transactions on the Blockchain in its implementation.

The following section highlights the application of the Brooks–Iyengar algorithm in combination with a multisensor environment when using Blockchain systems. The proposed procedure using the algorithm will provide a means to decentralize data sources. The Brooks-Iyengar algorithm for distributed control in the presence of noisy data combines Byzantine agreement with sensor fusion (Brooks & Iyengar, 1996), (Brooks & Iyengar, 1998), (Chen, Lam, & Fan, 2005). In implementing the Brooks-Iyengar algorithm, multiple sensors and sensor data are essential to provide a new technique. The Brooks-Iyengar algorithm decentralizes the data source, which is the value in block transactions if the data source is dominated by one or several groups.

### Multimodal Deep Learning Fusion

This model was designed by Diamantidou (2019), presenting a new multimodal Deep Learning methodology for filtering and combining data from various unimodal approaches used to detect UAVs. In particular, this study aimed to detect and classify potentially hazardous UAVs based on the fusion procedure (combining) the features of UAV detection provided by the unimodal component (Diamantidou, Lalas, Votis, & Tzovaras, 2019).

The concept used in this paper is an implementation of the Multilayer Perceptron architecture, which is combined with multimodal deep learning fusion. The fusion algorithm has three input streams: infrared stream,

optro stream, and 2D radar stream. The extracted feature of the neural network in unimodal is a high representation of the raw input data to the neural network. At the same time, the implementation is based on the Perceptron Multilayer architecture. The Perceptron Multilayer algorithm consists of a merging layer and three fully connected layers (solid layer).

Figure 4 illustrates the proposed architectural concept and design of the data fusion framework. The neural network architecture has been designed with three input streams: thermal image stream (infrared), visual image stream (optro), and 2D radar stream. The implementation of the proposed methodology involves a merged layer to combine the three input streams mentioned above. Each stream is a different input tensor. The output of the concatenation layer returns a tensor containing the concatenation of all inputs. Utilizing the merged layer makes it easy to manipulate multiple input tensors because the unimodal input features are not closely related.

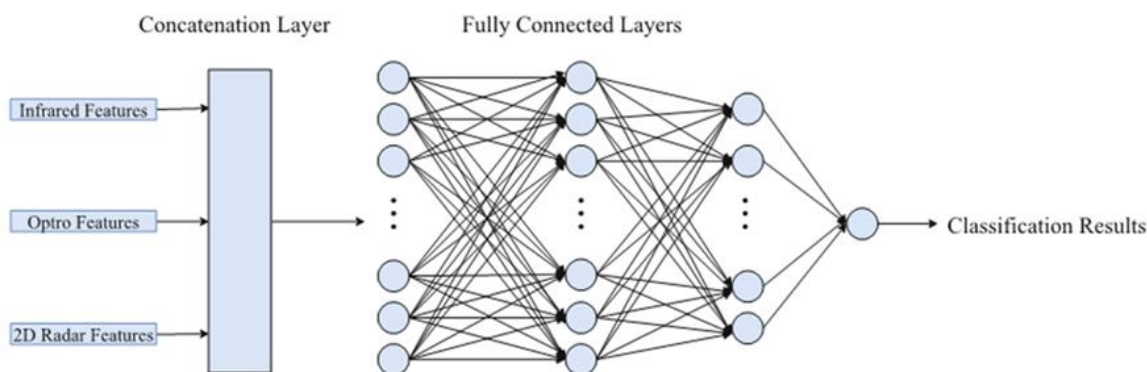

**Figure 4. Multilayer Perceptron architecture for deep learning fusion frameworks**(Diamantidou et al., 2019).

## Results and Discussion

From the four algorithms that have been described previously, we will discuss how to implement these algorithms into the c-UAV system. In addition, each performance resulting from combining multisensor data based on these algorithms will also compare each performance to achieve an optimal and efficient algorithm. In a study using a combined algorithm of Kalman filter and Multi-Layer Perceptron, the problem of multisensor data fusion is applied to linear systems(Safari et al., 2014). The highest sampling rate is uniform, but the lower sampling rate is different and asynchronous. Each sensor system observes the state independently. Assuming that the state dynamics at the highest sampling rate are known and that the sampling rate ratio between sensor systems is a positive integer, a single-level approximation model for the original design is developed. A parallel Kalman filter is used for state estimation at each sampling rate, and a neural network is used for integrating state estimates.

The simulation results show better performance than previously published methods based on combined Kalman filtering due to a neural network-based sensor fusion approach. Future work may include extending the proposed algorithm to cases where the sampling rate ratio is a non-integer, the sampling rate ratio varies stochastically, or the highest sampling rate ratio is not uniform. Other future work could include the use of

nonlinear networks and neural networks for data fusion from multiple Kalman filter outputs (e.g., fuzzy systems). This algorithm cannot be applied with sensor inputs with different features and dimensions because it causes many misperceptions of sensor data obtained. The proposed algorithm uses Enhanced MapReduce considering that the proposed algorithm is more efficient than a simple Java iteration implementation, as shown in Figure 5.

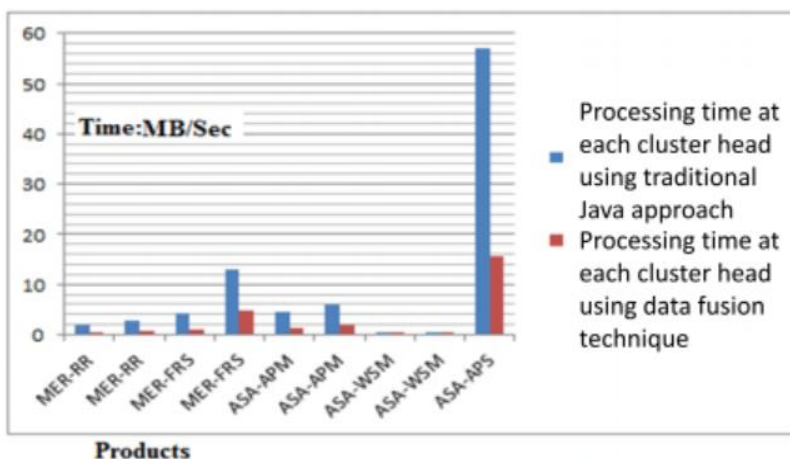

**Figure 5. Processing time is taken from various products(Safari et al., 2014).**

This paper describes the transaction protocol, consensus algorithm, and proof of the work-based consensus algorithm of a standard blockchain. The Brooks-Iyengar algorithm decentralizes the data source of the appropriate measurement and thereby ensures the integrity of transactions on the Blockchain (Iyengar, Ramani, & Ao, 2019). However, standard blockchains with only one sensor in IoT or Smart Grids cannot decentralize data sources, thus making transaction values on Blockchain controlled by centralized nodes.

And most recently, a multimodal deep learning algorithm has been implemented to detect and identify the presence of UAVs in a protected area. Various experiments have been carried out to evaluate the proposed method(Gao, Zhong, & Li, 2011). By examining the results, it is observed that the Multilayer Perceptron algorithm has great potential to study the relationships and differences between the input data and achieve high classification results in UAV detection problems. The main achievement of the proposed approach is that this method successfully increases confidence inaccuracy while data from different modalities are combined. The results of fusion detection are compared with the unimodal detection of each modality to assess the performance of the fusion model. Figure 6[a-c] presents the results of UAV detection in the form of prediction probabilities based on unimodal features. In addition, Figure 6[d] offers the results of UAV detection derived from the fusion model. As Figure 6[d] shows, a much better detection result was observed than Figure 6[a-c]. Improvements were noticed in detection accuracy when combined all three modalities were into the fusion model.



the 5<sup>th</sup> ICTROPS

International Conference  
for Tropical Studies and Its Applications

Islamic Development Bank 4in1 Project  
Project Implementation Unit  
University of Mulawarman



IsDB  
البنك الإسلامي للتنمية  
Islamic Development Bank

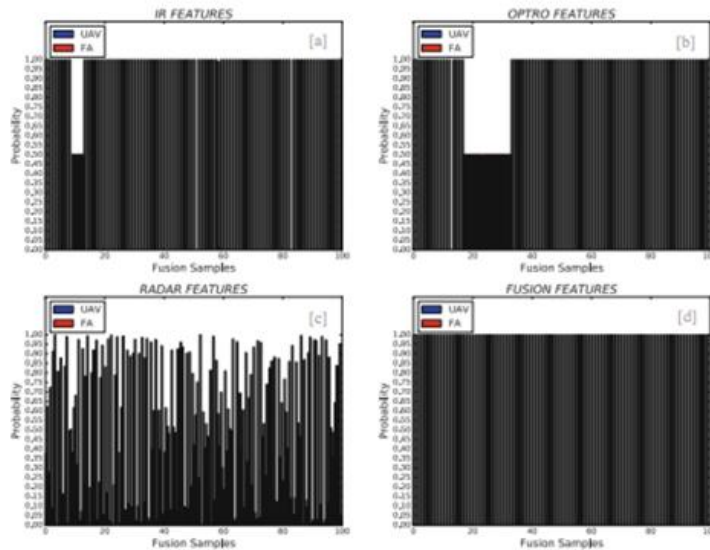

**Figure 6.** Possible predictions as a result of the unimodal features evaluation procedure assessed three modalities for different feature types, namely: [a] infrared feature, [b] optro feature, and [c] 2D radar feature. [d] Predictive results in fusion models including unimodal features of infra-red, optro, and 2D radar modalities. X-axis: number of instant test samples. Y-axis: predicted value in terms of probability(Diamantidou et al., 2019).

For quality estimation purposes, two metrics that are more important than classification accuracy have been used. Precision and recall are both essential model evaluation metrics(Buckland & Gey, 1994). Precision is defined as the number of True Positives (TP) over the number of True Positives (TP) plus the number of False Positives (FP). In addition, recall is defined as the number of True Positives (TP) over the number of True Positives (TP) plus the number of False Negatives (FN). F1-Score is the average of precision and recall harmonics. There is no doubt that our approach seeks to maximize the F1-Score. This model has been evaluated in actual UAV flight capture.

## Conclusions

The results of multi-sensor data fusion research based on several computational intelligence algorithms conclude that the most optimal algorithm used to detect various sensor features is Multimodal Deep Learning Fusion, by combining the Multilayer Perceptron algorithm in the learning process and testing the sensor data. In the research carried out, a multimodal neural network framework has been introduced, which can efficiently perform UAV detection tasks based on multiple input features. The proposed model architecture is based on the robust Multilayer Perceptron algorithm. In addition, it has also thoroughly assessed the model on two benchmark metrics, namely: prediction probability and evaluation quality metric. The fusion detection results have been compared with the unimodal detection results to extract the validated results. It has successfully demonstrated the effectiveness of multimodal data learning and precisely establishing the fusion model efficiently, which is suitable for UAV detection. The following research that the author will do in the future is to develop this multimodal deep learning algorithm to detect and identify the situational identification of UAVs.



the 5<sup>th</sup> ICTROPS  
International Conference  
for Tropical Studies and Its Applications

Islamic Development Bank 4in1 Project  
Project Implementation Unit  
University of Mulawarman



IsDB  
البنك الإسلامي للتنمية  
Islamic Development Bank



## ACKNOWLEDGMENT

The author gratefully acknowledges Mr. Azhari for guiding and mentoring the author for this paper. The authors also gratefully acknowledge the helpful comments and suggestions of the reviewers, which have improved the presentation.

## REFERENCES

- Brooks, R. R., & Iyengar, S. S. (1996). Robust distributed computing and sensing algorithm. *Computer*, 29(6), 53–60. <https://doi.org/10.1109/2.507632>
- Brooks, R. R., & Iyengar, S. S. (1998). *Multisensor fusion: fundamentals and applications with software*. Prentice-Hall, Inc.
- Buckland, M., & Gey, F. (1994). The relationship between recall and precision. *Journal of the American Society for Information Science*, 45(1), 12–19.
- Chang, Y. C., & Ko, T. T. (2014). An interactive dynamic multi-objective programming model to support better land-use planning. *Land Use Policy*, 36, 13–22. <https://doi.org/10.1016/j.landusepol.2013.06.009>
- Chen, Q., Lam, K. Y., & Fan, P. (2005). Comments on “Distributed Bayesian algorithms for fault-tolerant event region detection in wireless sensor networks.” *IEEE Transactions on Computers*, 54(9), 1182–1183. <https://doi.org/10.1109/TC.2005.140>
- Diamantidou, E., Lalas, A., Votis, K., & Tzovaras, D. (2019). Multimodal Deep Learning Framework for Enhanced Accuracy of UAV Detection. *Lecture Notes in Computer Science (Including Subseries Lecture Notes in Artificial Intelligence and Bioinformatics)*, 11754 LNCS, 768–777. [https://doi.org/10.1007/978-3-030-34995-0\\_70](https://doi.org/10.1007/978-3-030-34995-0_70)
- DIn, S., Ahmad, A., Paul, A., Ullah Rathore, M. M., & Jeon, G. (2017). A Cluster-Based Data Fusion Technique to Analyze Big Data in Wireless Multi-Sensor System. *IEEE Access*, 5(c), 5069–5083. <https://doi.org/10.1109/ACCESS.2017.2679207>
- Durrant-whyte, H., & Henderson, T. C. (2008). Multisensory. In *Encyclopedia of Neuroscience* (pp. 2479–2479). [https://doi.org/10.1007/978-3-540-29678-2\\_3650](https://doi.org/10.1007/978-3-540-29678-2_3650)
- Gao, S., Zhong, Y., & Li, W. (2011). Random weighting method for multisensor data fusion. *IEEE Sensors Journal*, 11(9), 1955–1961. <https://doi.org/10.1109/JSEN.2011.2107896>
- Iyengar, S. S., Ramani, S. K., & Ao, B. (2019). Fusion of the Brooks-Iyengar algorithm and Blockchain in the decentralization of the data source. *Journal of Sensor and Actuator Networks*, Vol. 8. <https://doi.org/10.3390/jsan8010017>
- Liggins, M. E., Hall, D. L., & Llinas, J. (2009). Handbook of Multisensor Data Fusion: Theory and Practice. In *CRC Press*.
- Ma, K., Zhang, H., Wang, R., & Zhang, Z. (2018). Target tracking system for multisensor data fusion. *Proceedings of the 2017 IEEE 2nd Information Technology, Networking, Electronic and Automation Control Conference, ITNEC 2017, 2018-Janua*, 1768–1772. <https://doi.org/10.1109/ITNEC.2017.8285099>



the 5<sup>th</sup> ICTROPS

International Conference  
for Tropical Studies and Its Applications

Islamic Development Bank 4in1 Project  
Project Implementation Unit  
University of Mulawarman



IsDB  
البنك الإسلامي للتنمية  
Islamic Development Bank



- Mahler, R. P. S. (2004). "Statistics 101" for multisensor, multitarget data fusion. *IEEE Aerospace and Electronic Systems Magazine*, 19(1 II), 53–64. <https://doi.org/10.1109/MAES.2004.1263231>
- Prime Consulting & Technologies. (2015). "ANTI-DRONE" SYSTEM OVERVIEW AND TECHNOLOGY COMPARISON. Retrieved from 2015 website: <https://anti-drone.eu/blog/anti-drone-publications/anti-drone-system-overview-and-technology-comparison.html>
- Safari, S., Shabani, F., & Simon, D. (2014). Multirate multisensor data fusion for linear systems using Kalman filters and a neural network. *Aerospace Science and Technology*, 39, 465–471. <https://doi.org/10.1016/j.ast.2014.06.005>
- Samaras, S., Diamantidou, E., Ataloglou, D., Sakellariou, N., Vafeiadis, A., Magoulianitis, V., ... Tzovaras, D. (2019). Deep learning on multisensor data for counter Uav applications—a systematic review. *Sensors (Switzerland)*, 19(22), 1–35. <https://doi.org/10.3390/s19224837>
- Sorsa, T., Koivo, H. N., & Koivisto, H. (1991). Neural networks in process fault diagnosis. *IEEE Transactions on Systems, Man, and Cybernetics*, 21(4), 815–825.
- Yi, D. A. I., & Min, M. A. (2009). Design and Implementation of Evaluation System for Multi-Sensor Data Fusion [J]. *Radar Science and Technology*, 4.
- Yu, Y. (2017). Distributed Target Tracking in Wireless Sensor Networks with Data Association Uncertainty. *IEEE Communications Letters*, 21(6), 1281–1284. <https://doi.org/10.1109/LCOMM.2017.2673824>
- Zhao, Z. Q., Zheng, P., Xu, S. T., & Wu, X. (2019). Object Detection with Deep Learning: A Review. *IEEE Transactions on Neural Networks and Learning Systems*, 30(11), 3212–3232. <https://doi.org/10.1109/TNNLS.2018.2876865>



## TEE-416

### Geographical Risk Factors of *Strongyloides stercoralis* infection in East Kalimantan Province, Indonesia

<sup>1,2\*</sup>Blego Sedionoto, <sup>2</sup>Sueptrakool Wasessombat, <sup>3</sup>Chuchard Punsawad, <sup>2,4</sup>Witthaya Anamart, <sup>2</sup>Jitbanjong Tangpong

<sup>1</sup>Department of Environmental Health, Faculty of Public Health Mulawarman University, Samarinda, 75123, Indonesia

<sup>2</sup>Doctoral Program in Biomedical Sciences, School of Allied Health Sciences, Walailak University, Thasala, 80160, Thailand.

<sup>3</sup>Department of Parasitology, School of Medicine, Walailak University, Thasala 80160, Thailand.

<sup>4</sup>Department of Environmental Health, School of Public Health, Walailak University, Thasala, 80160, Thailand

Corresponding Author\*: [blego\\_kesling@yahoo.com](mailto:blego_kesling@yahoo.com)

#### Abstract

*Strongyloides stercoralis*/ *S. stercoralis* infection is still challenge in public health problem especially in developing countries where have geographical risk factors especially geographical factors that are potential for transmitting of *S. stercoralis* infection. A cross-sectional study was performed among 213 participants from rural community of Muarakaman district and Marangkayu districts, East Kalimantan province, Indonesia. In this study used two diagnostic methods: Kato Katz and Koga agar plate culture/KAP culture for diagnosing of *S. stercoralis* infection. Pearson chi-square and odd ratio analysis were used for study correlation and level of geographical risk factors and *S. stercoralis* infection. We found *S. stercoralis* infection in East Kalimantan Province was 17 (8%). Geographical risk factors While pH of soil, clay content of soil, vegetation, and villages area have not correlated significant with *S. stercoralis* infection (p value > 0.05). Elevation from above sea ( $\geq 41.6$ m) was highest odd of *S. stercoralis* infection OR: 2.72 (95% CI: (1.30-5.66)). Geographical factors might support survival ability of *S. stercoralis* larvae for migrating and transmission. Essential geographical risk factors of the infections should be used for preventing program of reduction prevalence *S. stercoralis* infection.

**Keywords:** *S. stercoralis*, Geographical factors, East Kalimantan Province, Indonesia.

#### Introduction

The prevalence of *S. stercoralis* infection is of serious public health concern globally. *S. stercoralis* infection are prevalent in poor rural community in tropical and subtropical areas in many developing country (Wardell R et al 2017). They are transmitted through in protected contact with soil are endemic in tropical and temperate regions. The prevalence of *S. stercoralis* infection was estimated in 2010 that 100 people were infected million with strongyloides. Almost 70% of these infections occur in Asia. (Pullan et al, 2014, WHO, 2011 (Bethony et al. 2006).

*S. stercoralis* infection is transmitted through in protected contact with soil is endemic in tropical and temperate regions. Human acquire the *S. stercoralis* infection through direct skin contact with infective third stage larvae



the 5<sup>th</sup> ICTROPS

International Conference  
for Tropical Studies and Its Applications

Islamic Development Bank 4in1 Project  
Project Implementation Unit  
University of Mulawarman



IsDB  
البنك الإسلامي للتنمية  
Islamic Development Bank



where the soil was contaminated by human feces penetrate the intact human skin and eventually reach small intestine (Forrer et al. 2016).

Generally, *S. stercoralis* infection is found among poor people with poor environmental sanitation and where the climate is warm and humid (Bannon et al., 1995; Hall et al., 1994). Factors affecting difference in distribution of *S. stercoralis* infection may include good hygiene practices among population, availability of sewerage system and the length of rainy season. Environmental factors have contributed for transmission of diseases as well as growth and development of the worms (Anamnart et al, 2013; Prasit et al, 2016).

Environmental factors especially long rainy season may affect the decrease in prevalence of *S. stercoralis* infection. Prevalence of strongyloidiasis in south Thailand is lower than other parts of the country, in contrast, prevalence of hookworm infection is still high in the south. It is possibly because the failure in the control of hookworm infection due to 10 months long rainy season in southern Thailand contrasted with 4 months long rainy season in other parts (Anamnart et al., 2015). The study in Cambodia reported the lower prevalence of strongyloidiasis in area with heavy rainfall than in low rainfall area. Moreover, high amount of soil organic carbon content affect to the lower prevalence of strongyloidiasis (Khieu et al., 2014). Epidemiology study of hookworm infection and strongyloidiasis in Southern Laos showed 56.1% and 41% respectively where was heavy rainfall and poor sanitation. In this study Baerman and Kato-Katz techniques were used for detecting them (Vonghachack et al, 2015).

In rural East Kalimantan province Indonesia has environmental risk factors of prevalence of *S. stercoralis* infection that important to exploration association both of them. We perform a cross-sectional study in rural community in Muarakaman and Marangkayu district to analysis of geography, texture of soil, humidity, hookworm and strongyloides in pet, vegetation, elevation, volume rain, amount days of rain yearly, temperature and quality of soil as clay content, organic carbon of soil and pH of soil then was correlated with prevalence of *S. stercoralis* infection.

## Methodology

### Ethical consideration

Official permission and ethical clearance for collection human fecal samples was obtained from head master and teacher. The study protocol was approved by the Ethical Clearance committee on human right related to research involving human subjects, Walailak University HE: number WUEc-18-034-01.

### Study setting and population

The study was carried out in rural area of Muarakaman district and Marangkayu district East Kalimantan province, Indonesia. This research is a community based, was conducted during July 2018 to September 2019. Total of number participant is 213 participants who were joined and sent stool samples.

### Field Procedures

We collected third stool sample of participant, for collecting stool samples, the first day were requested to head of house hold and member of house hold for requesting stool sample, second day in the morning would start to collect stool samples, were brought to biomedical laboratory, school of Public Health Mulawarman University for diagnosis samples. Others day was done observation environmental condition houses surrounding village.

## Laboratory procedures

### Agar plate culture and Kato Katz technique

Agar plate culture was done as described by Koga et al., 1991. Briefly, a few grams of stool was placed at the center of nutrient agar and kept at room temperature for five days. Tracks from larva crawling and larvae or adult worms were observed. If positive, 10 ml of 10% formalin was added to agar surface for 5-10 minutes and transferred to centrifuged tube. Centrifugation at 2,500 rpm for 5 minutes and supernatant was discarded. The sediment will be examined for *S. stercoralis* larvae or adult worm.

For Kato-katz thick smear, 50 mg of stool was placed on slide and covered with a cellophane paper soaked in glycerin solution for 24 hours. The stool was spread out using rubber stick. After 30 minutes was examined and counted for eggs

### Risk factors data

Demographic data and personal hygiene of participants were collected by questionnaire, and sanitation facilities each house hold of participants were collected by observation, while geographical data was collected consist such as vegetation, elevation of soil, kind of pets, kind of soil around houses, length of rainy season, humidity and temperature per year. Quality of soil as organic carbon content, clay content and pH were diagnosed by soil laboratory Mulawarman University. Vegetation and kind of soil around houses were collected by observation form, kind of pet will be collected by questioner and observation, and length of rainy season, humidity and temperature per year will collected from Central Bureau of Statistics (<https://www.bps.go.id>) and Central Bureau of meteorology, climatology and Geophysical of Indonesia (<https://www.bmkg.go.id>).

### Data analysis

The prevalence of *S. stercoralis* infection was stratified according to demographic data, sanitation facilities and personal hygiene, environmental data, and reported by descriptive statistic. Statistical analysis was performed by Chi-square using SPSS verse 22. The correlation analysis chi-square to evaluate association of *S. stercoralis* infection with demographic data, sanitation facilities, personal hygiene, and environmental risk factors and the level of significance was considered as  $P < 0.05$  and the analysis of risk estimate by odds ratio Chi-Square with confidence interval 95%.

## Results and Discussion

### Study sample

A total of 213 individuals participated in this study. The age ranged between 2 and 70 years from 28 villages, with detail 12 villages from Muarakaman district and 16 villages from Marangkayu district, East Kalimantan province Indonesia. Among 28 villages collected each village 10-15 household with 2 to 3 participant each household, in enrolled we would collect 168 household and 296 participants. In this study collected 148 household and 213 participants. Males (60%) were dominant in the sample study. The age distribution of sample was 2 to 12(53.5%) and 13 and above (46.5%) Main occupation of the sample consist as farmer (32.9%), at home (25.8%), at school (38.0%) and others (3.3%).

### Parasitological findings

Prevalence *S. stercoralis* infection was diagnosed by Kato Katz technique and APC method showed of 426 tested samples from Muarakaman district and Marangkayu district with cases positive *S. stercoralis* infection 6 (3.2%) and 28 (11.9%). Overall the prevalence of *S. stercoralis* infection in East Kalimantan Province is 8%. Detail data of prevalence of *S. stercoralis* was explained in table 1

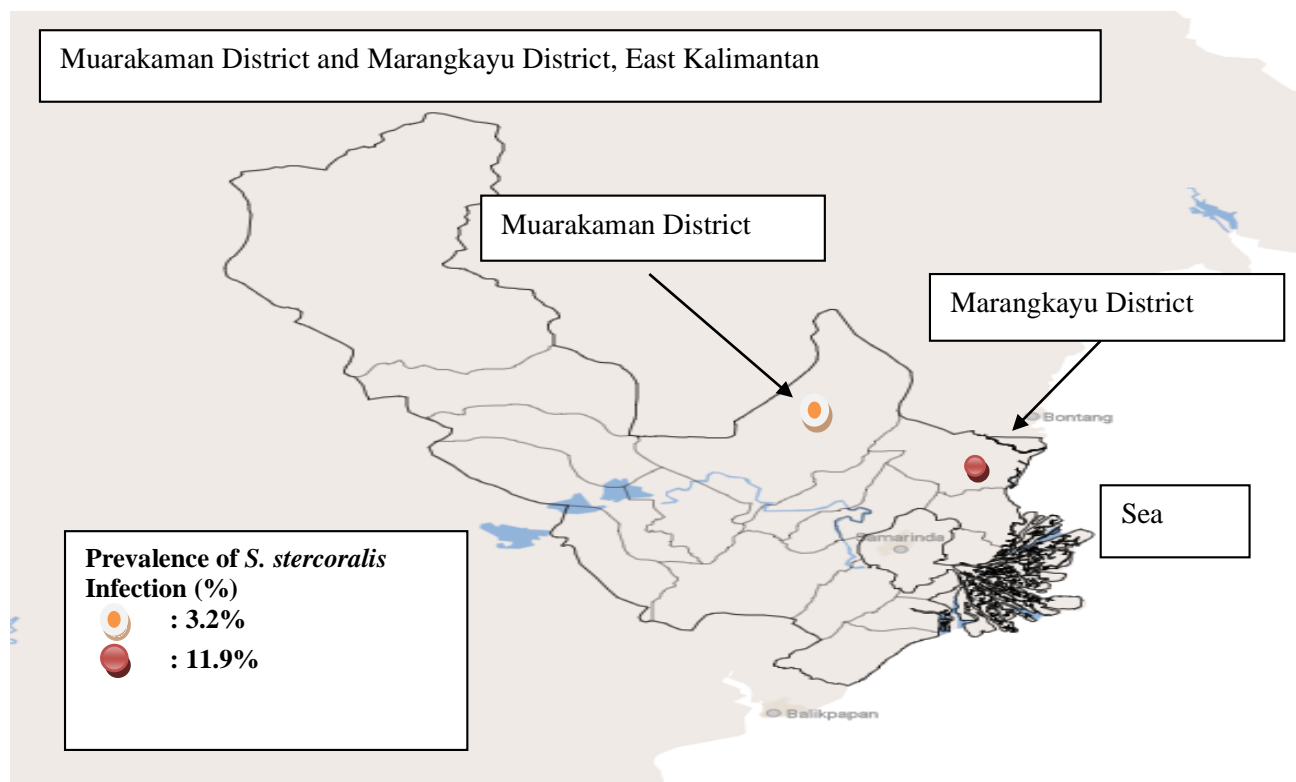

**Figure 1.** Prevalence of *S. stercoralis* infection in Muarakaman district and Marangkayu district, East Kalimantan province

### Association Geographical and *S. stercoralis* infection in East Kalimantan

The results statistical analysis between environmental risk factors with *S. stercoralis* infection showed several of environmental factors have correlated significant with *S. stercoralis* ( $p < 0.05$ ) such as district, organic carbon content in soil, texture of soil, humidity, temperature, elevation, number day of rainfall, rainfall volume, and *S. stercoralis* infection in dog. While pH of soil, clay content in soil, and dry or wet soil surrounding house vegetation, village areas, and having cat and dog and strongyloides infection in cat. have not significant correlated with prevalence of *S. stercoralis* infection in East Kalimantan Province.

The category of geographical risk factors which had percentage of positive *S. stercoralis* infection more than 8% and with significant correlation such as elevation from above sea (<41.6m), volume of rainfall (<3549mm<sup>3</sup>), number day of rainfall (<164days), humidity (<65.4%), temperature (<28.60C), organic carbon content in soil (<2.47%), texture of soil (sandy soil with organic material), district (Murangkayu District), the detail data in table 2.

**Table 1. Prevalence of *S. stercoralis* infection among Communities in East Kalimantan Province**

Infections	Muarakaman District		Marangkayu District		Total	
	Positive	Negative	Positive	Negative	Positive	Negative
<i>S. stercoralis</i>	3 (3.2%)	92 (96.8%)	14 (11.9%)	104 (88.1%)	17(8%)	196 (92%)

**Table 2. Geographical factors and *S. stercoralis* infection**

Variable	Category	<i>S. stercoralis</i>		P value
		Negative n (%)	Positive n (%)	
District	Muarakaman	92 (96.8)	3 (3.2)	0.001
	Marangkayu	104 (88.1)	14 (11.9)	
Organic carbon content in soil	<2.47%	78 (85.7)	13(14.3)	0.000
	≥2.47%	118 (96.7)	4 (3.3)	
pH soil	<5.85	95 (93.1)	7 (6.9)	0.414
	≥5.85	101 (91.0)	10 (9.0)	
Clay content in soil	<18.5%	79 (92.7)	7 (7.3)	0.634
	≥18.5%	107 (91.5)	10 (8.5)	
Temperature	<28.6 °C	104 (88.1)	14 (11.9)	0.001
	≥28.6 °C	92 (96.8)	3 (3.2)	
Humidity	<65.4%	104 (88.1)	14 (11.9)	0.001
	≥65.4%	92 (96.8)	3 (3.2)	
Number day of rainfall	<164 day	92 (96.8)	3 (3.2)	0.001
	≥164 day	104 (88.1)	14 (11.9)	
Rainfall volume	<3549 mm <sup>3</sup>	92 (96.8)	3 (3.2)	0.001
	≥3549 mm <sup>3</sup>	104 (88.1)	14 (11.9)	
Elevation from above of sea	<41.6m	99 (96.9)	3 (3.1)	0.001
	≥41.6m	102 (87.9)	14 (12.1)	
Texture of soil	Sandy soil with organic material	125 (89.9)	14 (10.1)	0.029
	Non-sandy soil with organic material	71 (95.9)	3 (4.1)	
Vegetation	Surrounding palm plantation and/or rubber plantation	155 (92.8)	12 (7.2)	0.248
	Surrounding rice field	41 (89.1)	5 (10.9)	
Village areas	Buffer river/sea	154 (92.8)	12 (7.2)	0.282
	Hill area	42 (89.4)	5 (10.6)	
Dry or wet soil surrounding house	Dry soil	154 (91.1)	15 (8.9)	0.182
	Wet soil	42 (95.5)	2 (4.5)	

### Geographical risk factors of *S. stercoralis* in East Kalimantan province

Result analysis of estimating risk between environmental risk factor with *S.stercoralis* infection by chi-square odds ratio analysis had showed several environmental risk factors with OR> 1, but the odds ratio had deferent each others of infection.

Analysis OR in district explained that Marangkayu district OR: 2.66 (95%CI: 1.28-5.54) is higher risk than Muarakaman district OR: 0.64 (95%CI: 0.54-0.77) district for *S.stercoralis* infection. Marangkayu district where have temperature (<28.6 0C), humidity (<65.4), number day of rainfall (<164 days), and rainfall volume

(3549-4000 mm<sup>3</sup>) is higher OR=2.66 (1.28-5.54).

Organic carbon content in soil <2.47% was higher OR than 2.47-4.04% was OR: 2.56 (95%CI: 1.38-4.71) and OR: 0.52 (95%CI: 0.45-0.65) respectively. Elevation with category 41.6-50 m, has higher OR than < 41.6m with OR: 2.72 (95%CI: 1.30-5.66) and OR: 0.63 (95%CI: 0.53-0.76) respectively, and texture of soil with category sandy soil with organic material higher OR than non-sandy soil with OR: 2.05 (95%CI: 0.98-4.29) and OR: 0.77 (95%CI: 0.66-0.92) respectively, detailed data in table 3.

**Table 3. Geographical risk factors of *S. stercoralis* in East Kalimantan province**

Essential risk factors	Category	<i>S. stercoralis</i>		OR (95%CI)
		Negative n (%)	Positive n(%)	
District	Muarakaman	92 (96.8)	3 (3.2)	0.64 (0.54-0.77)
	Marangkayu	104 (88.1)	14 (11.9)	2.66 (1.28-5.54)
Organic carbon content in soil	<2.47%	156 (85.7)	13 (14.3)	2.56 (1.38-4.71)
	≥2.47%	118 (96.7)	4 (3.3)	0.52 (0.45-0.65)
Temperature	<28.6 °C	104 (88.1)	14 (11.9)	2.66 (1.28-5.54)
	≥28.6 °C	92 (96.8)	3 (3.2)	0.64 (0.54-0.77)
Humidity	<65.4%	104 (88.1)	14 (11.9)	2.66 (1.28-5.54)
	≥65.4%	92 (96.8)	3 (3.2)	0.64 (0.54-0.77)
Number day of rainfall	<164 day	92 (96.8)	3 (3.2)	0.64 (0.54-0.77)
	<28.6 °C	104 (88.1)	14 (11.9)	2.66 (1.28-5.54)
Rainfall volume	<3549 mm <sup>3</sup>	92 (96.8)	3 (3.2)	0.64 (0.54-0.77)
	≥3549 mm <sup>3</sup>	104 (88.1)	14 (11.9)	2.66 (1.28-5.54)
Elevation from above of sea	<41.6m	94 (96.9)	3 (3.1)	0.63 (0.53-0.76)
	≥41.6m	102 (87.9)	14 (12.1)	2.72 (1.30-5.66)
Texture of soil	Sandy soil with organic material	125 (89.9)	14(10.1)	2.05 (0.98-4.29)
	Non-sandy soil with organic material	71 (95.9)	3 (4.1)	0.77 (0.66-0.92)

The results statistical analysis between geographical risk factors with *S. stercoralis* infection showed several of environmental factors have correlated significant with *S. stercoralis* ( $p < 0.05$ ) such as district, organic carbon content in soil, texture of soil, humidity, temperature, elevation, number day of rainfall, rainfall volume, and *S. stercoralis* infection in dog. While pH of soil, clay content in soil, and dry or wet soil surrounding house vegetation, village areas, and having cat and dog and strongyloides infection in cat have not significant correlated with prevalence of *S. stercoralis* infection in East Kalimantan province.

Geographical risk factors which were highest association/correlation *S. stercoralis* infection were organic carbon content in soil ( $p < 0.0001$ ) that has 14.3% positive *S. stercoralis* infection with category organic carbon content <2.47%. The category of environmental risk factors which had percentage of positive *S. stercoralis* infection more than 9% and with significant correlation such as elevation from above sea (<41.6m), volume of rainfall (<3549 mm<sup>3</sup>), number day of rainfall (<164days), humidity (<65.4%), temperature(<28.6 °C), organic carbon content in soil(<2.47%), texture of soil (sandy soil with organic material), district (Marangkayu district),



the 5<sup>th</sup> ICTROPS

International Conference  
for Tropical Studies and Its Applications

Islamic Development Bank 4in1 Project  
Project Implementation Unit  
University of Mulawarman



IsDB  
البنك الإسلامي للتنمية  
Islamic Development Bank



District, organic carbon content in soil, texture of soil, humidity, temperature, elevation, number day of rainfall, rainfall volume, and *S. stercoralis* infection in dog have high significant with *S. stercoralis* infection due to the variables have contribution for surviving of parasitic larvae of *S. stercoralis* and potential increase for penetration the larvae to human via soil contact and pet contact. In this study had showed that quality of soil and climatology such as humidity, temperature have correlation with survive of *S. stercoralis* and heavy rainfall effected for reducing and increasing of distribution *S. stercoralis*. In general condition soil surrounding houses more than 80% covering with soil where close the location with plantation and forest that have high position for contamination from plantation and forest where some time the participants used open defecation on there. Warm temperature and texture of soil (sandy loam soil) could support mature of *S. stercoralis* eggs to develop filarial parasitic larvae. in addition heavy rainfall to make spreading stool with parasitic larva of *S. stercoralis* then has supported the larvae penetrated to skin surrounding at home or in plantation. *S. stercoralis* infection is neglected tropical diseases (Anamnart et al, 2010). In poor countries with tropical climate, where have environmental condition favorable for transmission *S. stercoralis* infection the prevalence still high. (Jongwutiwes et al, 1999).

Result analysis of estimating risk between environmental risk factor with *S. stercoralis* infection by chi-square odds ratio analysis had showed several environmental risk factors with odds ratio/OR > 1, but the odds ratio had deferent each others of infection. Analysis OR in district explained that Marangkayu district OR: 2.66 (95%CI: 1.28-5.54) is higher risk than Muarakaman OR: 0.64 (95%CI: 0.54-0.77) district for *S. stercoralis* infection. Marangkayu district where have temperature (<28.6 0C), humidity (<65.4), number day of rainfall (<164 days), and rainfall volume ( $\geq 3549$  mm<sup>3</sup>) is higher OR: 2.66 (95%CI: 1.28-5.54). Supporting environmental factor against survival of *S. stercoralis* infection was maximum temperature and minimum rainfall increased the odd of infection. *S. stercoralis* larvae same as with hookworm larvae that might have ability to migrate in to soil in presence of sufficient humidity (Forrer et al 2019). When communities defecated in rubber or palm plantation could be spread in village or rice field that condition was caused elevation plantation is higher than village and rice field elevation, run of water from plantation or forest when rainfall maybe bring the eggs or larvae *S. stercoralis* from hill to village and field rice. Potential infected together via field rice and rubber and palm plantations adult communities also for children when they were playing around houses.

*S. stercoralis* infection no significant correlated with clay content, texture, vegetation and village areas although the prevalence co-infection still high in several geographical factors. Collaboration many geographical 1 risk factors could support the survival of larvae the worms. Geographical risk factors of *S. stercoralis* infection in East Kalimantan has similar with southern Thailand including long rainy season, temperature and several geography area, then the prevalence of hookworm infection in East Kalimantan Province (44.1%) is higher than in southern Thailand but equal for *S. stercoralis* infection, (Anamnart, et al., 2015). Epidemiology study of *S. stercoralis* infection Southern Laos showed was 41% where has heavy rainfall and poor sanitation. (Vonghachack et al, 2015).

Prevalence *S. stercoralis* infection was higher in Marangkayu district (11.9%) than Muarakaman district (3.2%). even though the prevalence *S. stercoralis* was lower than hookworm infection in overall cases. The range prevalence *S. stercoralis* infection in East Kalimantan Province have different with study in Preah Vihear province Cambodia, where the prevalence of *S. stercoralis* infection was 48.6%, in contrast the prevalence of *S. stercoralis* infection was lower in East Kalimantan province, Indonesia (8 %). The geographical factors should effect against increasing or decreasing prevalence of *S. stercoralis* infection in rural area. (Forrer et al

2018).

Organic carbon content in soil  $<2.47\%$  was higher OR than  $\geq 2.47\%$  was OR: 2.56 (95%CI: 1.38-4.71) and 0.52 (0.45-0.65) respectively. Elevation with category 41.6-50 m, has higher OR than  $< 41.6\text{m}$  with OR: 2.72 (95%CI: 1.30-5.66) and OR: 0.63 (95%CI: 0.53-0.76) respectively. and texture of soil with category sandy soil with organic material higher OR than non-sandy soil with OR: 2.05 (95%CI: 0.98-4.29) and OR: 0.77 (95%CI: 0.66-0.92) respectively. The study was similar with study in Cambodia reported the lower prevalence of *S. stercoralis* infection in area with heavy rainfall than in low rainfall area. Cambodian study also explained that high amount of soil organic carbon content affect to the lower prevalence of *S. stercoralis* infection (Khieu et al., 2014), equal with study in East Kalimantan which organic carbon soil more in became have effected for reducing *S. stercoralis*, in this study showed where organic carbon content in soil  $<2.47\%$  has higher *S. stercoralis* than organic carbon content  $\geq 2.47\%$ .

Geographical risk factors have significant correlation with high prevalence of *S. stercoralis* such as district, humidity, temperature, volume and amount day of rain organic carbon of soil, texture of soil and elevation, the environmental factors make survive of infective larvae of *S. stercoralis* infection, had explained with Garcia (2007) that a significant increase the prevalence of *S. stercoralis* infection with environmental conditions. Changing environmental conditions, specifically deforestation and subsequent silting of locally river, have caused periodic flooding with deposition on layer of sandy loam topsoil could increase soil moisture, and supporting by low quality of sanitation facilities and hygiene personal to add the increasing of *S. stercoralis* infection. These conditions, all of which are conducive to *S. stercoralis* transmissions, have allowed *S. stercoralis* infection to reemerge as an important human pathogen in this area (Forrer, et al 2018).

## Conclusions

Geographical factors in East Kalimantan province, Indonesia have significant correlation and high odd ratio of *S. stercoralis* infection such as district, humidity, temperature, volume and amount day of rain organic carbon of soil, texture of soil, and elevation from above sea. Supporting geographical factor against survival of *S. stercoralis* infection was maximum temperature and minimum rainfall increased the odd of infection. *S. stercoralis* larvae might have ability to migrate in to soil in presence of sufficient humidity. Geographical factors might support survival ability of *S. stercoralis* larvae for migrating and transmission. Essential geographical risk factors of the infections should be used for preventing program of reduction prevalence *S. stercoralis* infection.

## ACKNOWLEDGEMENT

We grateful to participants and local authorities of Muarakaman district and Marangkayu district, East Kalimantan province. We deeply thank the Dean of School of Public Health Mulawarman University and the Dean School of Allied Health Walailak University for giving us the permission to use the laboratory and supporting approval of letter for this research. This work was supported by Walailak University grant (contract no 17/2561).



## REFERENCES

- Anamnart W, Pattanawongsa, A, Maleewong, P, Intapan., Morakote N, Janwan., P, Maleewong., W (2013). Detrimental Effect of Water Submersion of Stools on Development of *Strongyloides stercoralis*. PLoS ONE 8, e82339.
- Anamnart, W, Pattanawongsa, A, Maleewong, P, Intapan., and Maleewong W. (2010). Albendazole Stimulates the Excretion of *Strongyloides stercoralis* Larvae in Stool Specimens and Enhances Sensitivity for Diagnosis of Strongyloidiasis. Journal of Clinical Microbiology, 48, 4216–4220
- Bethony J, Brooker S, Albonico M, Geiger SM, Loukas A, Diemert D & Hotez PJ. (2006). Soil-Transmitted Helminth Infections: Ascariasis, Trichuriasis, and Hookworm. Lancet 367,1521-1532
- Brooker S, Bethony J, Hotez PJ. Human hookworm infection in the 21st century. AdvParasitol.2004;58:197-288.
- Boonjarasspinyo S, Boonmars T, Kaewsamut B, Ekobol N, Laummaunwa P, Aukkanimart R, Wonkchalee N, Juasook A, Sriraj P (2013). A Cross-Sectional Study on Intestinal Parasitic Infection in Rural Communities, Northeast Thailand. Korean J Parasitol Vol 51, No 6:727-734
- Forrer A, Khieu V, Schar F, Vounatsau P, Chammartin F, Marti H, Muth S, Odermatt P (2018). *Strongyloides stercoralis* and hookworm co-infection: spatial distribution and determinants in Preah Vihear Province, Cambodia. Parasit Vectors (2018) 11:33
- Forrer A, Khieu V, Vounatsau P, Sithithaworn P, Ruantip S, Huy R, et al (2019). *Strongyloides stercoralis*: Spatial distribution of a highly prevalent and ubiquitous soil-transmitted helminth in Cambodia. PloS Negl Trop Dis 13(6):e0006943. <https://doi.org/10.1371/journal.pntd.0006943>
- Garcia, Lynne Shore, (2007), Diagnostic Medical Parasitology, ASM Press Washington D.C Fifth Edition Chapter 10, 266-270
- Hall A, Conway DJ, Anwar KS & Rahman ML. (1994). *Strongyloides stercoralis* in an Urban Slum Community in Bangladesh: Factors Independently Associated with Infection. Trans R Soc Trop Med Hyg 88, 527-530
- Katz N, Chaves A & Pellegrino J. (1972). A Simple Device for Quantitative Stool Thick-Smear Technique in *Schistosomiasis mansoni*. Rev Inst Med Trop Sao Paulo 14, 397-400.
- Khieu V, Schär F, Marti H, Bless PJ, Char MC, Muth S & Odermatt P. (2014). Prevalence and Risk Factors of *Strongyloides stercoralis* in Takeo Province, Cambodia. Parasit Vectors 7, 221.15
- Khieu V, Schär F, Marti H, Sayasone S, Duong S, Muth S & Odermatt P. (2013). Diagnosis, Treatment and Risk Factors of *Strongyloides stercoralis* in School children in Cambodia. PLoS Negl Trop Dis 7, e2035.
- Kitvatanachai S, Pipitgool V (1999) Efficacy of three methods in the detection of hookworm and *Strongyloides stercoralis* infections. J Trop Med Parasitol 22: 80–81.
- Koga K, Kasuya S, Khamboonruang C, Sukhavat K, Ieda M, Takatsuka N, Kita K & Ohtomo H. (1991). A Modified Agar Plate Method for Detection of *Strongyloides stercoralis*. Am J Trop Med Hyg 45, 518-521.
- Naves and Costa-Cruz. (2013). High prevalence of *Strongyloides stercoralis* infection Among The Elderly in



the 5<sup>th</sup> ICTROPS

International Conference  
for Tropical Studies and Its Applications

Islamic Development Bank 4in1 Project  
Project Implementation Unit  
University of Mulawarman



IsDB  
البنك الإسلامي للتنمية  
Islamic Development Bank



Brasil. Rev. Ins. Med. Trop Sao Paulo 55 (5) 309-313

Prasit Na-Ek, OranuchSanpool, Jurairat Jongthawin, Witthaya Anamnart, Pewpan M. Intapan Pennapa Chamavit, Wanchai Maleewong (2016). Restoration of Hookworm Egg Development after Prolonged Storage in Stool Suspension. Parasitol Res 115, 2817–2823

Peter Steinmann, Peiling Yap, JürgUttinger, Zun-Wei Du, Jin-Yong Jiang et al (2015). Control of soil-transmitted helminthiasis in Yunnan province, People's Republic of China: Experiences and lessons from a 5-year multi-intervention trial. Acta Tropica 141, 271–280

YouthanavanhVonghachack, SomphouSayasone, DalounyBouakhasith, KeokaTaisayavong, KongsapAkkavong, Peter Odermatt. (2015) Epidemiology of *Strongyloides stercoralis* on Mekong Islands in Southern Laos. ActaTropica 141, 289–294.

Olsen A, van Lieshout L, Marti H, Polderman T, Polman K, Steinmann P, Stothard R, Thybo S, Verweij JJ &Magnussen P. (2009). Strongyloidiasis- -The Most Neglected of The Neglected Tropical Diseases? Trans R Soc Trop Med Hyg 103, 967-972

Khieu V, Schar F, ForrerA, Hattendorf, Marti, Duong S, VounatsouP, Muth s, OdermattP, High Prevalence and Special Distribution of *Strongyloides stercoralis* in Rural Cambodia. Plosnegl trop dis 2014,; 8 e2854

Jongwutiwes S, Charoenkom M, Sithichareonchai P, Akaraborvorn P, Putaportip C, Increased Sensitivity of Routine Laboratory Detection of *Strongyloides stercoralis* and Hookworm by Agar-Plate Culture. Trans R Soc Trop med Hyg, 1999; 93: 398-400

Siddiqui AA &Berk SL. (2001).Diagnosis of *Strongyloides stercoralis* Infection. Clin Infect Dis 33, 1040-1047

Wardell R, Clements ACA, Lal A, Summers D, Llewellyn S, Campbell SJ, et al. (2017) An environmental assessment and risk map of *Ascaris lumbricoides* and *Necator americanus* distributions in Manufahi District, Timor-Leste. PLoS Negl Trop Dis 11(5)

## TEE-421

# Comparison of Content and Status of the C-Organic, Nitrogen, C/N Ratio, Soil pH, and Organic Matter in Rainfed, Tidal and Swampy Rice Fields (Case Study in Three Villages, in East Kalimantan)

<sup>1,2</sup>Suria Darma, <sup>2</sup>Syamad Ramayana, <sup>2</sup>Sadaruddin, <sup>2</sup>Bambang Suprianto

<sup>1</sup>Laboratorium Agronomi Fakultas Pertanian Universitas Mulawarman

<sup>2</sup>Program Studi Agroekoteknologi Fakultas Pertanian Universitas Mulawarman

*Corresponding Author\*: suriadarmaidris@gmail.com*

### Abstract

The purpose of the research is to identify the current condition of land fertility; for improvement and sustainability of land productivity, and for sustainable management actions. The research was carried out by taking 5 soil samples in 10 plots of rainfed rice fields, tidal rice fields and swamp rice field that had been determined, using a soil drill with a depth of  $\pm 30$  cm; took 1 kg compositely from each of 5 samples and analyzed at the Laboratory of Soil Science, Faculty of Agriculture, Mulawarman University. The results of laboratory analysis provide information that: 1). Rainfed rice fields show, on average: C-organic content in moderate status (2.08%), Total N content in moderate status (0.34%), C/N ratio in low status (6.28), pH value in very acidic status (4.48), organic matter content, in moderate status (3.57%). 2). Tidal rice fields, showing the average: C-organic content in high status (3.27%), Total N content in moderate status (0.41%), C/N ratio in low status (7.89), pH value in very acidic status (4.28), organic matter content, in moderate status (3.58%); 3). Swamp Rice field, shows the average: C-organic content in high status (3.06%), Total N content in moderate status (0.46%), C/N ratio in low status (6.84), pH value in very acidic status (4.25), organic matter content, in high status (5.26%).

**Keywords:** comparison, C-Organic, Organic matter, rain-fed, tidal and swampy swamps

### PRELIMINARY

Organic matter is important for the soil, most farmers use inorganic fertilizers more often to provide nutrients in the soil for plants, even though the use of inorganic fertilizers causes a decrease in soil quality, which will damage the soil and the production of plants planted will decrease in quantity and production quality. Soil organic matter is a collection of various complex organic compounds that are undergoing or have undergone a decomposition process, either in the form of humus or inorganic compounds resulting from mineralization, including heterotrophic and autotrophic microbes involved. In the management of soil organic matter the source can come from the application of organic fertilizers In the form of manure, green manure, compost, and biological fertilizers, organic matter has several important roles in the soil, namely as a provider of nutrients (especially nitrogen, phosphorus, and sulfur elements), increasing cation exchange capacity, as a food source for microorganisms, and functioning as a source of food for microorganisms. The main organic matter is as a soil enhancer, this makes organic matter important for the soil, organic material in the form of composted or fresh is useful for: 1) increasing soil organic matter levels, 2) improving physical, chemical, and biological fertility of the soil, 3) Increase diversity, population and activity microbes and facilitate the provision of



the 5<sup>th</sup> ICTROPS

International Conference  
for Tropical Studies and Its Applications

Islamic Development Bank 4in1 Project  
Project Implementation Unit  
University of Mulawarman



IsDB  
البنك الإسلامي للتنمية  
Islamic Development Bank



nutrients in the soil, 4) Provide macro and micro nutrients. The harvested area of Indonesian rice crops in 2020 is 10 657 274.96 million ha with a production of 54 649 202.24 tons of dry milled rice (BPS, 2020), Currently, productive rice fields in Indonesia are experiencing challenges in terms of quantity and quality. The area of underproductive land is decreasing, due to land conversion. In terms of quality, productivity is decreasing due to the decline in land fertility. The decline in fertility of paddy fields is thought to be caused by mismanagement, which seeks to produce as much as possible, with an intensive farming system that focuses on one type of land. certain crops by utilizing technological innovations and the use of high “external inputs” (inorganic fertilizers, inorganic pesticides) to obtain higher outputs in a relatively short time, without the effort of applying organic fertilizers (compost, manure, green manure, organic matter) cause the land to be "tired". Therefore, it is necessary to know the C-Organic status, C/N ratio, soil pH and organic matter content of paddy fields in East Kalimantan, which is a “driven” soil fertility, in order to identify the current fertility conditions for conservation of sustainable productivity; and for sustainable management actions, in anticipation of the plan to relocate the Capital of the Government of the Republic of Indonesia to the East Kalimantan region, which has implications for the 'exodus' of a number of human populations.

## MATERIALS AND METHODS

### Time and place

The time of the research, the research was carried out in February 2021, starting from preparation, sampling, sample preparation and chemical analysis at the Soil Science Laboratory, Agriculture Faculty, Mulawarman University.

### Place of Research

Field research was carried out in Rainfed Paddy Fields in Sarinadi Village, Kota Bangun District, Kutai Kertanegara Regency; Tidal Paddy Fields in Sidomulyo Village, Anggana District, Kutai Kertanegara Regency and Rawa Lebak Rice Fields in Rawa Mulia Village, Babulu District, North Penajam Paser Regency, East Kalimantan

### Materials and tools

Materials: 10 soil samples from each rainfed rice field in Sarinadi Village, Kota Bangun District, Kutai Kertanegara Regency; Tidal Rice Fields in Sidomulyo Village, Anggana District, Kutai Kertanegara Regency and Swampy Paddy Fields in Rawa Mulia Village, Babulu District, East Kalimantan PPU Regency, Total 30 samples

Tools: Soil drill, plastic clip, GPS, Camera, stationery, sample container

### Procedure

The research implementation includes the following activities:

1. Taking each of 5 soil samples for each specified rainfed, tidal and swamp paddy field, using a soil drill with a depth of  $\pm 30$  cm
2. Five (5) Soil samples from each rainfed, tidal and swampy paddy field were collected separately,
3. Each of the five soil samples was mixed and stirred evenly, 1 kg was taken compositely and put in a plastic clip,
4. The composites of each soil sample were brought to the Soil Science Laboratory, Faculty of Agriculture, Mulawarman University, to carry out soil chemical analysis procedures,
5. Limited soil chemical treatment and analysis – C-organic content, C/N ratio, soil pH and organic matter



the 5<sup>th</sup> ICTROPS

International Conference  
for Tropical Studies and Its Applications

Islamic Development Bank 4in1 Project  
Project Implementation Unit  
University of Mulawarman



IsDB  
البنك الإسلامي للتنمية  
Islamic Development Bank



content - by the Laboratory of Soil Science, Faculty of Agriculture, Mulawarman University

## Data analysis

The results of the chemical analysis are limited to the sample of rice fields that are the research site, in the three villages that have been determined, as follows:

Table 1. Results of Chemical Analysis of Limited Soil from Rainfed Rice Fields in Sarinadi Village, Kota Bangun District, Kutai Kertanegara Regency, East Kalimantan

No.	Code			organic C	Total N	C/N Ratio	pH	Organic matter (%)
	Sample	Lab	Coordinate					
1.	SP5 SD 1	6934	S 12994887,12 – E 44729,33	2,04 (M)	0,35 (M)	5,80 (L)	4,26 (VA)	3,51 (M)
2.	SP5 SD 2	6935	S 12994902,57 – E 44509,43	2,33 (M)	0,39 (M)	5,94 (L)	4,45 (VA)	4,01 (M)
3.	SP5 SD 3	6936	S 12994871,66 – E 45341,61	2,12 (M)	0,35 (M)	6,03 (L)	4,80 (A)	3,65 (M)
4.	SP5 SD 4	6937	S 12995128,06 – E 44789,13	1,82 (L)	0,27 (M)	6,78 (L)	4,29 (VA)	3,13 (L)
5.	SP5 SD 5	6938	S 12994522,05 – E 44679,55	2,55 (M)	0,39 (M)	6,61 (L)	4,54 (A)	4,39 (M)
6.	SP5 SD 6	6939	S 12995216,68 – E 44212,23	2,04 (M)	0,34 (M)	5,99 (L)	4,42 (VA)	3,51 (M)
7.	SP5 SD 7	6940	S 12994793,51 – E 44287,14	2,48 (M)	0,31 (M)	8,05 (L)	4,27 (VA)	4,27 (M)
8.	SP5 SD 8	6941	S 12994277,13 – E 42224,27	1,62 (L)	0,29 (M)	6,50 (L)	4,67 (A)	2,79 (L)
9.	SP5 SD 9	6942	S 12994935,95 – E 42269,25	1,80 (L)	0,31 (M)	5,73 (L)	4,46 (VA)	3,10 (L)
10.	SP5 SD 10	6943	S 12994631,68 – E 42586,75	1,96 (L)	0,36 (M)	5,39 (L)	4,59 (A)	3,37 (L)
Average				2,08 (M)	0,34 (M)	6,28 (L)	4,48 (VA)	3,57 (M)

Description: Determination of status based on Table 4. M = Moderate, L=Low, VA=Very Acidic

Table 2. Results of Chemical Analysis of Limited Soil from Tidal Rice Fields in Sidomulyo Village, Anggana District, Kutai Kertanegara Regency, East Kalimantan

No.	Code			organic C	Total N	C/N Ratio	pH	Organic matter (%)
	Sample	Lab	Coordinate					
1.	ANG I SP 1	6945	S 00° 32' 18,0" – E 117° 16' 27,3"	3,45 (H)	0,38 (M)	9,19 (L)	4,10 (VA)	5,93 (H)
2.	ANG I SP 2	6946	S 00° 32' 18,3" – E 117° 16' 25,8"	2,93(M)	0,39 (M)	7,57 (L)	4,54 (A)	5,04 (M)
3.	ANG I SP 3	6947	S 00° 32' 18,2" – E 117° 16' 24,5"	2,71 (M)	0,27 (M)	9,89 (L)	4,35 (VA)	4,66 (M)
4.	ANG I SP 4	6948	S 00° 32' 7,06" – E 117° 16' 31, 6"	2,91 (M)	0,31 (M)	9,27 (L)	4,37 (VA)	5,01 (M)
5.	ANG I SP 5	6949	S 00° 32' 7,54" – E 117° 16' 40,52"	3,23 (H)	0,34 (M)	9,45 (L)	4,14 (VA)	5,56 (H)
6.	ANG II SP 1	6950	S 00° 32' 18,62" – E 117° 17' 2,8"	3,88 (H)	0,58 (M)	6,69 (L)	3,86 (VA)	6,67 (H)
7.	ANG II SP 2	6951	S 00° 32' 9,8" – E 117° 16' 54,6"	3,30 (H)	0,48 (M)	6,82 (L)	4,17 (VA)	5,68 (H)
8.	ANG II SP 3	6952	S 00° 32' 17,9" – E 117° 16' 54,9"	2,13 (M)	0,35 (M)	6,06 (L)	4,25 (VA)	3,66 (M)
9.	ANG II SP 4	6953	S 00° 32' 23,0" – E 117° 16' 58,0"	3,36 (H)	0,48 (M)	7,06 (L)	4,28 (VA)	5,78 (H)
10.	ANG II SP 5	6954	S 00° 32' 23,0" – E 117° 17' 02,7"	3,27 (H)	0,48 (M)	6,86 (L)	4,80 (A)	5,62 (H)
Average				3,27 (H)	0,41 (M)	7,89 (L)	4,28 (VA)	3,58 (M)

Description: Determination of status based on Table 4. M = Moderate, L=Low, VA=Very Acidic

Table 3. Results of Chemical Analysis of Limited Soil from Swampy Rice Fields in Rawa Mulia Village, Long Kali District, North Penajam Paser Regency, East Kalimantan

No.	Code			organic C	Total N	C/N Ratio	pH	Organic Matter (%)	
	Sample	Lab	Coordinate						
			X						Y
1.	RM Sdr 5	6934	12965680.89	-173954.3713	2,57 (M)	0,40 (M)	6,38 (L)	4,23 (VA)	4,42 (M)
2.	RM Sdr 11	6935	12965468.68	-173635.7675	3,73 (H)	0,51 (H)	7,32 (L)	4,40 (VA)	6,42 (H)
3.	RM Sdr 15	6936	12965627.48	-173643.5137	2,07 (M)	0,31 (M)	6,73 (L)	4,10 (VA)	3,56 (M)
4.	SMD 3	6937	12965806.61	-173669.657	3,16 (H)	0,45 (M)	7,05 (L)	4,16 (VA)	5,44 (H)
5.	SMD 4	6938	12965696.22	-173726.785	2,18 (M)	0,36 (M)	6,08 (L)	4,34 (VA)	3,75 (M)
6.	BAM 6	6939	12965392.63	-173497.607	3,53 (H)	0,60 (H)	7,08 (L)	4,11 (VA)	6,07 (H)
7.	BAM 11	6940	12965389.28	-173432.4259	3,00 (M)	0,43 (M)	6,96 (L)	4,20 (VA)	5,16 (M)
8.	BAM 13	6941	12965542.27	-173767.4524	2,98 (M)	0,49 (M)	6,05 (L)	4,37 (VA)	5,13 (M)
9.	DA 2 S 01	6942	12965733.99	-173851.692	3,86 (H)	0,57 (H)	6,77 (L)	4,40 (VA)	6,64 (H)
10.	DA 2 S 02	6943	12965529.68	-173924.3124	3,50 (H)	0,44 (M)	7,95 (L)	4,19 (VA)	6,02 (H)
Average					3,06 (H)	0,46 (M)	6,84 (L)	4,25 (VA)	5,26 (H)

Description: Determination of status based on Table 4. M = Moderate, L=Low, VA=Very Acidic

Determination of the status of the results of chemical analysis on 10 samples of Tidal Rice Fields in Sidomulyo Village, Tadah Rice Fields in Sari Nadi Village and Swampy Rice Fields in Rawa Mulia Village, using the

table below:

Table 4. Criteria for Assessment of Soil Chemical Properties for Agriculture – Best Conditions for Soil Fertility – Bogor Agricultural Research Institute

No.	Chemical Soil Properties	Method of Analysis	Very Low	Low	Moderate	High	Very High
1.	C (%)	Walkley and Black dichromate method	< 1,0	1,0 – 1,9	2,0 – 2,9	3,0 – 5,0	> 5,0
2.	Organic Matter	Multiply C content by 1.72	< 1,72	1,71 – 3,27	3,28 – 4,99	5,0 – 8,6	> 8,6
3.	N (%)	Kjehldahl method	< 0,10	0,10 – 0,20	0,21 - 0,50	0,51 – 0,75	> 7,5
4.	C/N ratio	Dividing C content by N content	< 5	5 - 10	11 - 15	16 – 25	> 25
5.	pH H <sub>2</sub> O	Very Acidic < 4,5	Acid 4,5 – 5,5	Slightly Acid 5,6 -6,5	Neutral 6,6 – 7,5	Slightly Alcaline 7,6 – 8,5	Alcaline > 8,5

Sumber : Balittanah, Bogor

## RESULT AND DISCUSSION

### Results

#### C-organic

Results Based on laboratory analysis, it is known that the average C-organic content in rainfed rice fields in Sari Nadi Village is moderate status (2.08%); tidal rice fields in the village of Sidomulyo and swampy rice fields in the village of Rawa Mulia, in high status; namely 3.27% and 3.06%, respectively.

#### Total N

The results of the analysis of samples of paddy fields studied in the soil science laboratory, it was found that the average total N content in all samples of paddy fields; rainfed, tidal and lowland swamps, showing moderate status, namely respectively: 0.34%, 0.41% and 0.46%

#### C/N ratio

In the parameter C/N ratio studied on all samples of paddy fields; rainfed, tidal and lowland swamps, by the soil science laboratory, information was obtained that the average C/N ratio showed a low status, respectively: 6.28; 7.89; and 6.84.

#### pH

Results of laboratory analysis of soil samples taken from the field; rainfed, tidal and lowland swamps, showing very acidic status, namely: 4.48; 4.28 and 4.25.

#### Organic matter content

Observation of parameters of organic matter content in all soil samples, provides information that the average number of soil organic matter content; rainfed, tidal and swampy rice field, indicating medium and high status; respectively : 3.57%; 3.58%, and in high status, namely: 5.26%

Table 5. Comparative summary of soil chemical properties of each paddy field

No.	Chemical Soil Properties	Paddy Field		
		Rainfed	Tidal	Swampy
1.	C (%)	2,08 (M)	3,27 (H)	3,06 (H)
2.	N (%)	0,34 (M)	0,41 (M)	0,46 (M)
3.	C/N ratio	6,28 (L)	7,89 (L)	6,84 (L)



the 5<sup>th</sup> ICTROPS

International Conference  
for Tropical Studies and Its Applications

Islamic Development Bank 4in1 Project  
Project Implementation Unit  
University of Mulawarman



IsDB  
البنك الإسلامي للتنمية  
Islamic Development Bank



4.	pH	4,48 (VA)	4,28 (VA)	4,25 (VA)
5.	Organic Matter (%)	3,57 (M)	3,58 (M)	5,26 (H)

## Discussion

### C-organic

Following the criteria for assessing soil properties for agriculture, in the best soil fertility conditions by Balittanah Bogor (2009), the organic C content in high status is in the range, 3.0% - 5.0%. According to Friyanto (2020), at a C-organic content of 3-5%, the balance of the soil ecosystem is still maintained. Soil microbes still get adequate food intake from soil organic C, both beneficial and unbeneficial microbes.

The factors that affect the organic matter content in the soil include: climate, vegetation/soil organisms, topography, parent material and cropping management. Human activities are part of agricultural management, through the provision of organic fertilizers will determine the organic content of the soil will affect the organic matter content of the soil.

Based on the results of the analysis, it was found that the rainfed rice fields in the village of Sari Nadi were in the medium category; tidal rice fields and swampy swamp rice fields, in Sidomulyo village and Rawa Mulia village, respectively, were in the high category (close to the medium category). For the conservation of sustainable land productivity; and for management actions, it is necessary to improve the cultivation system, through the provision of organic fertilizers to complement inorganic fertilizers, as well as efforts to manage organic matter left over from harvests on the land. This is in line with the results of research by Yuniarti, et al (2019), which showed that the application of various organic fertilizers and fertilizers N, P and K had an effect on the content of organic C, C/N, and N uptake in the soil inceptisols.

### N Total

Nitrogen element, plays a very important role in the formation of plant cells, tissues, and plant organs. Nitrogen has the main function as a synthetic material for chlorophyll, protein, and amino acids. The characteristics of nitrogen-deficient plants can be recognized from the lower leaves. The leaves in this section turn yellow due to lack of chlorophyll. In further processing, the leaves will dry up and fall off. The bones under the surface of the young leaves will appear pale. Plant growth is slow, stunted and weak. As a result, flower and seed production will be low (Mukhlis, 2017). Nitrogen elements, in plant or plant biomass, were found in Turi mini (*Sesbania rostrata*) aged 45 days producing the highest average nitrogen content (5.1%) (Baba, et al. 2020); Kirinyu 2.48%; Gamal 3.09% and Lamtoro 3.01% (Pu'u, YMSW and C. Mutiara. 2018), papaya, Gliricidia, cassava, binahong, moringa, sweet potato, *cromolaena*, peanut, and African plants, the leaves contain nitrogen which is quite dominant (Pradana, WE 2020)

Based on the results of laboratory analysis, it was found that the total N content in all samples of paddy fields; rainfed, tidal and lowland swamps, indicating moderate status. For sustainable conservation of land productivity, it is necessary to improve cultivation, especially in nitrogen fertilization, it must be combined with green manure, foliar compost, and manure. The above is in line with Hutomo et al (2015) that the application of green manure *Tithonia diversifolia* at a dose of 10 Mg.ha<sup>-1</sup> can increase maize yields by 9.2 Mg.ha<sup>-1</sup>. Nisaa', et al (2016), the addition of green manure *Clotalaria juncea* 25 Mg.ha<sup>-1</sup> can reduce the use of inorganic fertilizers by 50% and the addition of green manure *Clotalaria mucronata* 25 Mg.ha<sup>-1</sup> can reduce the use of inorganic fertilizers by 25%.



the 5<sup>th</sup> ICTROPS

International Conference  
for Tropical Studies and Its Applications

Islamic Development Bank 4in1 Project  
Project Implementation Unit  
University of Mulawarman



IsDB  
البنك الإسلامي للتنمية  
Islamic Development Bank



### C/N ratio

A high C/N ratio indicates the presence of a relatively large amount of weathered soil material (eg cellulose, fat and wax), on the other hand, a smaller C/N ratio indicates that organic matter is more easily decomposed. The C/N ratio will affect the availability of nutrients, the C/N ratio is inversely proportional to the availability of nutrients, if the C/N ratio is high then the nutrient content is slightly available to plants, whereas if the C/N ratio is low then the availability of nutrients is high and plants can meet their needs. Soil C/N ratio ranges from 10-12. If the organic matter has a C/N ratio close to or equal to the soil C/N ratio, then the material can be used by plants. Organic matter that can be absorbed by plants is organic material with a C/N ratio close to the soil C/N ratio, which is about 12-15 and a temperature almost the same as the ambient temperature.

Based on the results of the analysis, it is known that all observed samples show the C/N ratio parameter is in a low status, it is necessary to increase this number by applying organic fertilizer or organic matter, which in practice can be done by increasing weed biomass after harvesting and returning crop residues to paddy fields.

### pH

The ideal soil acidity (pH) for plants is between pH 5.5 – 7.5. If the soil or planting medium has a high acidity level, then the elements of magnesium, calcium and phosphorus will be chemically bound so that they cannot be absorbed by plants. In such conditions, the elements of aluminum and manganese will be toxic and detrimental to plants. The availability of nutrients for plants decreases and there is a decrease in crop production. If the soil or growing media has a high alkaline level (alkaline), micro nutrients such as copper, manganese, zinc and iron will be chemically bound and cannot be absorbed by plants. Soil acidity is caused by utilization without a break, and the excessive use of chemical fertilizers, the Neurafarm Team (2021), conveyed how to deal with acid soil by (1) liming, (2) intensive application of organic matter, (3) intensive phosphate fertilizer application, (4) conducting regulation of cropping systems and, (5) Provision of decomposing microorganisms.

Based on the results of the analysis on the pH parameters, all samples showed a very acidic status. This is very critical to the sustainability of the productivity of the paddy fields. So it is necessary to immediately handle the above through liming with Dolomite  $\text{CaMg}(\text{CO}_3)_2$  gradually, as well as the provision of organic fertilizer. Provision of animal manure can increase soil chemical properties such as pH, C-organic and N-total (Palupi, 2015)

### Organic matter content

Organic matter in the soil has 2 roles: as a storage (has a high cation exchange capacity) and a supplier of essential nutrients for plants (through weathering of biomass). Able to improve physical properties (forming soil structure) and soil chemistry (eg pH buffer) and soil biology. According to Friyandito (2020) Some sources of soil organic matter addition are: plant residues, green manure, manure, industrial waste, household waste. Based on the results of the analysis on the parameters of the organic matter content, the rainfed rice fields in Sari Nadi Village showed the medium category, the others were high. Immediate treatment is needed to increase the number of organic matter content in medium status paddy fields, and maintenance at high status through the provision of soil organic matter additives.



## CONCLUSIONS AND SUGGESTIONS

### Conclusion

Based on the results of laboratory analysis on 30 samples taken from rainfed rice fields in Sari Nadi Village, Tidal Rice Fields in Sidomulyo Village and Swampy Rice Fields in Rawa Mulia Village, with the aim of identifying current fertility conditions, for conservation of productivity sustainability; and for sustainable management actions, it can be concluded as follows:

1. Samples of rainfed rice fields in Sari Nadi Village showed that Organic C content, moderate (2.08%); total N content, moderate (0.34%), low in C/N ratio (6.28), pH soil was very acidic (4.48) and organic matter content, moderate (3.57%); in samples of tidal rice fields in Sidomulyo Village, showed that the organic C content was high (3.27%), total N content was moderate (0.41%), C/N ratio was low (7.89), soil pH was very acidic (4.28) and organic matter content was moderate (3.58%); in the swampy rice fields in Rawa Mulia Village, showed high Organic C content (3.06%), total N content was moderate (0.46%), low in C/N ratio (6.84), soil pH very acidic (4.25) and organic matter content was high (5.26%),
2. The sustainability of the land productivity of all the rice fields studied will decline in the future if soil acidity is not immediately corrected,
3. It is necessary to take action to conserve the sustainability of productivity, immediately, on the parameters of pH, C/N ratio, and organic C, while on other parameters, maintenance actions need to be taken.

### Suggestion

Based on the latest fertility conditions from the results of laboratory analysis on sample samples from rainfed rice fields, tidal rice fields and lebak swamp rice fields, it is recommended:

1. It is necessary to handle the acidity of the rice fields above through liming with Dolomite  $\text{CaMg}(\text{CO}_3)_2$  gradually,
2. It is necessary to handle the parameters of organic C, C/N ratio, N content and organic matter content through intensive application of organic matter/organic fertilizer.

## ACKNOWLEDGMENT

Thank you to the Management of the Faculty of Agriculture who has given the Research Grant Fund for the Faculty of Agriculture, Mulawarman University for the 2020-2021 fiscal year, the Research Team

## REFERENCES

- Baba, B; M, Aldi; A.U. Istiqamah; A. Karre; E, Syam'un; M. Riadi dan M. Jayadi. 2020. Biomass Production and Nutrient Content of Turi Mini Green Manure (*Sesbania Rostrata*) At Different Plant Distances And Harvest Ages. *Jurnal Agroplantae* Vol 9 No 2 (2020). <https://ppnp.e-journal.id/agro/article/view/220>.
- Badan Penelitian dan Pengembangan Pertanian, 2011, *Agro Inovasi : Variety of Innovations to Support Regional Agriculture*, Edition 3-9 Agustus 2011 No,3417 Tahun XLI, Buleleng
- Balai Penelitian Tanah, (2009). *Technical Guide Edition 2. Chemical Analysis of Soil, Plants, Water and Soil*. Balai penelitian tanah. Bogor
- Friyandito (2020). *The role of organic matter in soil fertility and plant nutrition*. . Best planter indonesia.



the 5<sup>th</sup> ICTROPS

International Conference  
for Tropical Studies and Its Applications

Islamic Development Bank 4in1 Project  
Project Implementation Unit  
University of Mulawarman



IsDB  
البنك الإسلامي للتنمية  
Islamic Development Bank



<https://bestplanterindonesia.com/peranan-bahan-organik-dalam-kesuburan-tanah-dan-nutrisi-tanaman>

Hutomo, I.P; Mahfudz, dan S Laude. 2015. Effect of Tithonia Diversifolia Green Manure on Growth and Yield of Corn (*Zea Mays L.*). e-J. Agrotekbis 3 (4). <https://media.neliti.com/media/publications/244413-none-ac89d61e.pdf>

Mukhlis, 2017. Macro and Micro Nutrients needed by Plants. North Luwu Regency Agriculture Office. [https://dtphp.luwuutarakab.go.id/berita/3/unsur-hara-makro-dan-mikro-yang-dibutuhkan-oleh-tanaman.html?fb\\_comment\\_id=3189773321086078\\_3795980587132012](https://dtphp.luwuutarakab.go.id/berita/3/unsur-hara-makro-dan-mikro-yang-dibutuhkan-oleh-tanaman.html?fb_comment_id=3189773321086078_3795980587132012)

Nisaa'.A.K; B. Guritno dan T. Sumarni. 2016. Effect of Green Manure *Crotalaria Mucronata* And *C. Juncea* On Growth And Yield Of Soybean (*Glycine Max L. Merril*). Jurnal Produksi Tanaman, Volume 4 Nomor 8. <https://media.neliti.com/media/publications/132484-ID-pengaruh-pupuk-hijau-crotalaria-mucronat.pdf>

Palupi, N.P. 2015. Analysis of Soil Acidity and Organic C of *Imperata cylindrica* Vegetated Soil Due to Provision of Chicken Manure and Goat Manure. Media Sains, Volume 8 Nomor 2. <https://ldikti11.ristekdikti.go.id/jurnal/pdf/d324635d-3092-11e8-9030-54271eb90d3b/>

Pradana, W.E. 2020. No need to bother looking for fertilizer if farmers understand the ingredients for making NPK fertilizer. Pandangan Jogja.Com. <https://kumparan.com/pandangan-jogja-com/tak-perlu-pusing-cari-pupuk-kalau-petani-paham-bahan-penyusun-pupuk-npk-1uBEliO07ih/full>

Pu'u, Y.M.S.W dan C. Mutiara. 2018. Variety of Plants In Situ as Organic Fertilizer in Detusoko and Kelimutu Districts, Ende Regency. Jurnal Bioindustri Vol. 1. No. 1, November 2018

Yuniarti, A; M. Damayani; D. M. Nur (2019). Effect of Organic Fertilizer and N,P,K Fertilizer on C-Organic, N-Total, C/N, N Uptake, and Yield of Black Rice (*Oryza Sativa L. Indica*) In Inceptisols. Jurnal Pertanian Presisi (Journal Of Precision Agriculture) Vol 3, No 2 (2019)

## TEE-423

# Essential Ecological Risk Factors of *Strongyloides stercoralis* infection in Rural Areas Kutai Kertanegara, Indonesia

<sup>1,\*</sup>Blego Sedionoto, <sup>1</sup>Vivi Vilia Elvira, <sup>2</sup>Witthaya Anamart,

<sup>1</sup>Department of Environmental Health, Faculty of Public Health Mulawarman University, Samarinda, 75123, Indonesia

<sup>2</sup>Department of Environmental Health, School of Public Health, Walailak University, Thasala, 80160, Thailand  
Corresponding Author\*: [blego.sedionoto@gmail.com](mailto:blego.sedionoto@gmail.com)

## Abstract

*Strongyloides stercoralis* infections are still challenge in public health problem especially in developing countries where have ecological risk factors. In rural areas of Kutai Kertanegara regency have high risk of ecological factors of the prevalence *S. stercoralis* infections, A cross-sectional study was performed among 426 participants from rural community of Muarakaman District and Marangkayu Districts, Kutai Kertanegara Regency. In this study would show the infection rates, correlation analysis between environmental risk factors and prevalence of hookworm infection with statistical analysis. We performed a cross-sectional study among 426 participants from rural community of Muarakaman District and Marangkayu Districts, Kutai Kertanegara Regency East Kalimantan Province, Indonesia. In this study used two diagnostic methods: Kato Katz and Koga agar plate culture/KAP culture for diagnosing of *Strongyloides* infections. Pearson chi-square analysis was used for study correlation between ecological risk factors with *S. stercoralis* infection. *S. stercoralis* infections were found in this study; 34 (8.0%), Ecological risk factors have significant correlation and high odd ratio of prevalence of *S. stercoralis* infections. Essential ecological risk factors of the infections should use for preventing program of reduction prevalence of *S. stercoralis* infections.

**Keywords:** *S. stercoralis*, Ecological factors, Rural areas, Kutai Kertanegara

## Introduction

The prevalence of strongyloidiasis is of serious public health concern globally. Strongyloidiasis is prevalent in poor rural community in tropical and subtropical areas in many developing country. They are transmitted through in protected contact with soil are endemic in tropical and temperate regions. The prevalence of hookworm infection and strongyloidiasis was estimated in 2010 that 438.9 million people were infected with hookworm and 100 million with strongyloides. Almost 70% of these infections occur in Asia. (Wardell et al 2017; Pullan, et al, 2014, WHO, 2011 (Bethony et al. 2006).

Strongyloidiasis is transmitted through in protected contact with soil are endemic in tropical and temperate regions. Human acquire the strongyloidiasis through direct skin contact with infective third stage larvae where the soil was contaminated by human feces penetrate the intact human skin and eventually reach small intestine (Forrer et al. 2016). Strongyloidiasis are found among poor people with poor environmental sanitation and where the climate is warm and humid (Bannon et al., 1995; Hall et al., 1994). Factors affecting difference in distribution of strongyloidiasis may include good hygiene practices among population, availability of sewerage



the 5<sup>th</sup> ICTROPS

International Conference  
for Tropical Studies and Its Applications

Islamic Development Bank 4in1 Project  
Project Implementation Unit  
University of Mulawarman



IsDB  
البنك الإسلامي للتنمية  
Islamic Development Bank



system and the length of rainy season. Ecological factors have contributed for transmission of diseases as well as growth and development of the worms (Anamnart, et al, 2013; Prasit et al, 2016).

Ecological factors especially long rainy season may affect the decrease in prevalence of strongyloides stercoralis infection but not for hookworm infection. Prevalence of strongyloidiasis in south Thailand is lower than other parts of the country, in contrast, prevalence of hookworm infection is still high in the south. It is possibly because the failure in the control of hookworm infection due to 10 months long rainy season in southern Thailand contrasted with 4 months long rainy season in other parts (Anamnart et al., 2015). The study in Cambodia reported the lower prevalence of strongyloidiasis in area with heavy rainfall than in low rainfall area. Moreover, high amount of soil organic carbon content affect to the lower prevalence of strongyloidiasis (Khieu et al., 2014). Epidemiology study of hookworm infection and strongyloidiasis in Southern Laos showed 56.1% and 41% respectively where heavy rainfall and poor sanitation was. In this study Baerman and Kato-Katz techniques were used for detecting them (Vonghachack Y et al, 2015).

In rural Kutai Kertanegara Regency, Indonesia has ecological risk factors of prevalence of strongyloidiasis that important to exploration association both of them. We perform a cross-sectional study in rural community in Muarakiaman and Marangkayu district to analysis of geography, texture of soil, humidity, hookworm and strongyloides in pet, vegetation, elevation, volume rain, amount days of rain yearly, temperature and quality of soil as clay content, organic carbon of soil and pH of soil then was correlated with prevalence of hookworm infection and strongyloidiasis.

## Methodology

### Ethical consideration

The study protocol was approved by the Ethical Clearance committee on human right related to research involving human subjects, Walailak University HE: number WUEc-18-034-01.

### Study Setting and Population

The study was carried out in rural area of Muarakaman District and Marangkayu District Kutai Kertanegara Regency, Indonesia. This research is a community based, was conducted during July 2018 to September 2019 and second study on January to September 2021. Total of number participant is 426 participants that were counted by equal number of participants who joined and sent stool samples.

### Field Procedures

We collected third stool sample of participant, for collecting stool samples, the first day were requested to head of house hold and member of house hold for requesting stool sample, second day in the morning would start to collect stool samples, were brought to biomedical laboratory, school of Public Health Mulawarman University for diagnosis samples. Others day was done observation ecological condition of houses surrounding village.

### Laboratory Procedures

#### Agar plate culture and Kato Katz technique

Agar plate culture was done as described by Koga et al., 1991. Briefly, a few grams of stool was placed at the center of nutrient agar and kept at room temperature for five days. Tracks from larva crawling and larvae or adult worms were observed. If positive, 10 ml of 10% formalin was added to agar surface for 5-10 minutes

and transferred to centrifuged tube. Centrifugation at 2,500 rpm for 5 minutes and supernatant was discarded. The sediment will be examined for hookworm and *S. stercoralis* larvae or adult worm.

For Kato-katz thick smear, 50 mg of stool was placed on slide and covered with a cellophane paper soaked in glycerin solution for 24 hours. The stool was spread out using rubber stick. After 30 minutes was examined and counted for eggs

### Risk Factors Data

Demographic data and personal hygiene of participants were collected by questionnaire, and sanitation facilities each house hold of participants were collected by observation, while environmental data was collected consist such as vegetation, elevation of soil, kind of pets, kind of soil around houses, length of rainy season, humidity and temperature per year. Quality of soil as organic carbon content, clay content and pH were diagnosed by soil laboratory Mulawarman University. Vegetation and kind of soil around houses were collected by observation form, kind of pet will be collected by questioner and observation, and length of rainy season, humidity and temperature per year will collected from Central Bureau of Statistics (<https://www.bps.go.id>) and Central Bureau of meteorology, climatology and Geophysical of Indonesia (<https://www.bmkg.go.id>).

### Data Analysis

The prevalence of hookworm infection and *S. stercoralis* infection was stratified according to demographic data, sanitation facilities and personal hygiene, environmental data, and reported by descriptive statistic. Statistical analysis was performed by Chi-square using SPSS verse 21. The correlation analysis chi-square to evaluate association of *S. stercoralis* infection with demographic data, sanitation facilities, personal hygiene, and environmental risk factors and the level of significance was considered as  $P < 0.05$  and the analysis of risk estimate by odds ratio Chi-Square with confidence interval 95%.

### Results

#### Study Sample

A total of 426 individuals participated in this study. The age ranged between 2 and 70 years from 28 villages, with detail 12 villages from Muarakaman District and 16 villages from Marangkayu District, East Kalimantan Province Indonesia. Among 28 villages collected each village 10-15 household with 2 to 3 participant each household, in enrolled we would collect 336 household and 592 participants. In this study collected 296 household and 426 participants. Males (60%) were dominant in the sample study. The age distribution of sample was 2 to 12(53.5%) and 13 and above (46.5%) Main occupation of the sample consist as farmer (32.9%), at home (25.8%), at school (38.0%) and others (3.3%).

### Results and Discussion

#### Study sample

A total of 213 individuals participated in this study. The age ranged between 2 and 70 years from 28 villages, with detail 12 villages from Muarakaman district and 16 villages from Marangkayu district, East Kalimantan



the 5<sup>th</sup> ICTROPS

International Conference  
for Tropical Studies and Its Applications

Islamic Development Bank 4in1 Project  
Project Implementation Unit  
University of Mulawarman



IsDB  
البنك الإسلامي للتنمية  
Islamic Development Bank



province Indonesia. Among 28 villages collected each village 10-15 household with 2 to 3 participant each household, in enrolled we would collect 168 household and 296 participants. In this study collected 148 household and 213 participants. Males (60%) were dominant in the sample study. The age distribution of sample was 2 to 12(53.5%) and 13 and above (46.5%) Main occupation of the sample consist as farmer (32.9%), at home (25.8%), at school (38.0%) and others (3.3%).

### Parasitological findings

Prevalence hookworm infection and *strongyloides stercoralis* infection were diagnosed by Kato Katz technique and APC method showed of 426 tested samples from community have 186 (43.7%) cases found positive with hookworm infection and 34 (8.0%) cases found positive with *strongyloides* infection and co-infection 30 (7.0%). Detail data of prevalence of hookworm, *strongyloides stercoralis* and co-infection were explained below::

### Ecology Factors and *S. stercoralis* infection in East Kalimantan Province

The results statistical analysis between ecological risk factors with *S. stercoralis* infection showed several of ecological risk factors have correlated significant with *S. stercoralis* ( $p < 0.05$ ) such as district, organic carbon content in soil, texture of soil, humidity, temperature, elevation, number day of rainfall, rainfall volume, and *S. stercoralis* infection in dog. While pH of soil, clay content in soil, and dry or wet soil surrounding house vegetation, village areas, and having cat and dog and *strongyloides* infection in cat. have not significant correlated with prevalence of *S. stercoralis* infection in Kutai Kertanegara Regency.

Ecological risk factors which were highest association/correlation *S. stercoralis* infection were organic carbon content in soil ( $p = 0.000$ ) and live together with human infected with *S. stercoralis*  $p = 0.000$ . The category of ecological risk factors which had percentage of positive *S. stercoralis* infection more than 9% and with significant correlation such as elevation from above sea ( $< 41.6\text{m}$ ), volume of rainfall ( $< 3549\text{mm}^3$ ), number day of rainfall ( $< 164\text{days}$ ), humidity ( $< 65.4\%$ ), temperature ( $< 28.6\text{ }^\circ\text{C}$ ), organic carbon content in soil ( $< 2.47\%$ ), texture of soil (sandy soil with organic material), district (Murangkayu District), and *S. stercoralis* infection in dog. Live together with human infected with *S. stercoralis* was highest percentage of *S. stercoralis* infection (84.2%) and highest significant correlation with  $p\text{-value} = 0.000$ .

### Odd Ratio (OR) Ecological risk factor of *S. stercoralis*

Result analysis of estimating risk between environmental risk factor with *S. stercoralis* infection by chi-square odds ratio analysis had showed several environmental risk factors with  $\text{OR} > 1$ , but the odds ratio had deferent each others of infection. Analysis OR in district explained that Marangkayu District (2.66 (1.28-5.54)) is higher risk than Muarakaman (0.64 (0.54-0.77)) district for *S. stercoralis* infection. Marangkayu district where have temperature ( $< 28.6\text{ }^\circ\text{C}$ ), humidity ( $< 65.4$ ), number day of rainfall ( $< 164\text{ days}$ ), and rainfall volume (3549-4000  $\text{mm}^3$ ) is higher  $\text{OR} = 2.66$  (1.28-5.54). Organic carbon content in soil  $< 2.47\%$  was higher OR than 2.47-4.04% was 2.56 (1.38-4.71) and 0.52 (0.45-0.65) respectively. Elevation with category 41.6-50 m, has higher OR than  $< 41.6\text{m}$  with  $\text{OR} = 2.72$  (1.30-5.66) and  $\text{OR} = 0.63$  (0.53-0.76) respectively. and texture of soil with category sandy soil with organic material was higher OR than non-sandy soil with  $\text{OR} = 2.05$  (0.98-4.29) and 0.77 (0.66-0.92) respectively. Occupation, drinking water, and personal hygiene especially usual wash foot after soil contact, usual un-cook vegetable and wash hand after soil contact were high risk of *S. stercoralis* infection were 2.08 (0.99-4.35), 1.99 (1.08-3.69) 1.26 (1.01-1.58) 1.27 (0.98-1.63), and 1.27 (1.02-1.58) respectively. Having dog infected with *S. stercoralis* infection high risk of *S. stercoralis* infection in participants, the statistical analysis showed  $\text{OR} = 4.42$  (1.14-17.15). Participants whose infected cat by *S.*



the 5<sup>th</sup> ICTROPS

International Conference  
for Tropical Studies and Its Applications

Islamic Development Bank 4in1 Project  
Project Implementation Unit  
University of Mulawarman



IsDB  
البنك الإسلامي للتنمية  
Islamic Development Bank



*S. stercoralis* 14 (8.9%) while participants whose infected dog by *S. stercoralis* 32 (9.9%), analysis pearsonX<sup>2</sup> *S. stercoralis* infection in human has correlation significant with infected dog by *S. stercoralis* ( $p = 0.009$ ). the correlation did not significant with infected cat by *S. stercoralis* ( $p = 0.607$ ). Having dog infected with *S. stercoralis* infection high risk of *S. stercoralis* infection in participants, the statistical analysis showed OR=4.42 (1.14-17.15). Live together human infected *S. stercoralis* was high risk of *S. stercoralis* infection with OR=16.74(4.36-64.22). Participants who have infected dog by *S. stercoralis* high risk with *S. stercoralis* with OR=4.42 (1.14-17.15).

The prevalence of hookworm infection in Muarakaman District is higher than in marangkayu district was 61.1% and 38.9% respectively, while the prevalence *Strongyloides stercoralis*, Marangkayu District (11.9%) is higher than Muarakaman District (3.2%). Prevalence of co-infection was showed in Marangkayu District (10.2%) where is higher than Muarakaman District (3.2%). The study similar with south Thailand study where hookworm infection higher than *S. stercoralis* (Anamnart, et al., 2015). Deference of ecological factor between Muarakaman District and Marangkayu District should be affected the higher hookworm infection and lower of *S. stercoralis* in Muarakaman district such as vegetation surrounding area of villages and geographical location where Muarakaman District be located surrounding palm plantation and river area. Similar study in Manufahi District, Timor Leste where is rural area with prevalence of hookworm infection was 62.8%.(Nerry SV, et al 2015)

The results statistical analysis between environmental risk factors with hookworm and *S. stercoralis* co-infection showed several of environmental factors have correlated significant with hookworm and *S. stercoralis* co-infection such as district, organic carbon content in soil, texture of soil, humidity, temperature, elevation, number day of rainfall, rainfall volume, and hookworm and *S. stercoralis* co-infection in dog. While pH of soil, clay content in soil, and dry or wet soil surrounding house vegetation, village areas, and having cat and dog and strongyloides infection in cat. have not significant correlated with prevalence of hookworm and *S. stercoralis* co-infection in East Kalimantan Province.

Environmental risk factors which the higher association/correlation hookworm and *S. stercoralis* co-infection were organic carbon content in soil ( $p=0.000$ ) and live together with human infected with hookworm and *S. stercoralis* co-infection ( $p=0.000$ ). The category of environmental risk factors which had percentage of positive *S. stercoralis* infection more than 9% and with significant correlation such as elevation from above sea (<41.6m), volume of rainfall (<3549 mm<sup>3</sup>), number day of rainfall (<164days),humidity (<65.4%), temperature(<28.6 0C), organic carbon content in soil(<2.47%), texture of soil ( sandy soil with organic material), district (Murangkayu District), and *S. stercoralis* infection in dog. Live together with human infected with *S. stercoralis* was highest percentage of *S. stercoralis* infection (82.4%) and highest significant correlation with  $p$  value= 0.000. District, organic carbon content in soil, humidity, temperature, elevation, number day of rainfall, rainfall volume, and *S. stercoralis* infection in dog have high significant with hookworm, *S. stercoralis* and co-infection that due to the variables have contribution for surviving of parasitic larvae of hookworm and *S. stercoralis* then potential increase for penetration the larvae to human via soil contact and pet contact. In this study had showed that quality of soil and climatology such as humidity, temperature have correlation with survive of hookworm and *S. stercoralis* and heavy rainfall effected for reducing and increasing of distribution hookworm and *S. stercoralis*. In general condition soil surrounding houses more than 80% covering with soil where close the location with plantation and forest that have high position for contamination from plantation and forest. And in addition personal hygiene and sanitation facilities still not save for protection skin from larvae hookworm and *S. stercoralis* also in file rice and palm or rubber plantation. (Anamnart, W et al, 2010).



the 5<sup>th</sup> ICTROPS

International Conference  
for Tropical Studies and Its Applications

Islamic Development Bank 4in1 Project  
Project Implementation Unit  
University of Mulawarman



IsDB  
البنك الإسلامي للتنمية  
Islamic Development Bank



In poor countries with tropical climate, where have environmental condition favorable for transmission hookworm and *S.stercoralis* infection the prevalence still high (Jongwutiwes s et al, 1999).

*S.stercoralis* infection and co-infection no significant correlated with clay content, texture, vegetation and village areas although the prevalence co-infection still high in several environmental factor. Collaboration many environmental risk factors could support the survival of larvae the worms. Environmental factors of hookworm and *S. stercoralis* infection in Kutai Kertanegara Regency, Indonesia has similar with south Thailand including long rainy season, temperature and several geography area, then the prevalence of hookworm infection in East Kalimantan Province (44.1%) is higher than in south Thailand but equal for *S.stercoralis* infection, (Anamnart, et al., 2015). In contrast quote by epidemiology study of *S.stercoralis* infection Southern Laos showed was 41% where has heavy rainfall and poor sanitation. (Vonghachack et al, 2015).

Analysis OR in district explained that Muarakaman District high risk for hookworm infection, in contrast Marangkayu District high risk for *S. stercoralis* and co-infection. Village areas had high risk for hookworm is buffer area (OR=2.54) while *S. stercoralis* and co-infection were higher in surrounding rubber and palm plantation where closed with buffer areas Buffer areas of river or sea were highest environmental risk factor hookworm infection with OR 2.54.

Temperature in category <28.6 0C become high risk factor for *S. stercoralis* and co-infection high with OR=2.66 and OR=2.32 respectively while hookworm infection has high risk in temperature category >28.50C-29 0C, while humidity category <65.4 65.4-66 high risk for *S. stercoralis* and co-infection with OR=2.66 and OR=2.32 respectively , but humidity category 65.4-66 high risk for hookworm infection with OR= 1.84. Elevation from above sea in category <41.6m is high risk hookworm infection while *S. stercoralis* and co-infectio were high risk in elevation 41.6-50m. Organic carbon content <2.47% was higher risk for *S. stercoralis* and co-infection, organic carbon content in soil 2.47-4.04% was high risk for hookworm infection. Organic carbon content >2.47% become protective environmental risk factor for *S. stercoralis* and co-infection. The study was similar with study in Cambodia reported the higher of hookworm infection and the lower prevalence of *S.stercoralis* infection in area with heavy rainfall than in low rainfall area. Cambodian study also explained that high amount of soil organic carbon content affect to the lower prevalence of *S. stercoralis* infection (Khieuet al., 2014), equal with study in East Kalimantan which organic carbon soil more in became have effected for reducing *S. stercoralis* but did not for hookworm infection.

Rainy season with rainfall in category number day of rainfall <164 days yearly was high risk for hookworm infection while *S. stercoralis* and co-infection still high risk in rainfall 164-174 days. Volume rainfall in category <3459 was higher risk for hookworm infection and the volume rainfall 3459-4000mm<sup>3</sup> was higher risk for *S. stercoralis* and co-infection. Supporting environmental factor against survival of hookworm and *S. stercoralis* . When communities defecated in rubber or palm plantation could be spread in village or rice field that condition was caused elevation plantation is higher than village and rice field elevation, run of water from plantation or forest when rainfall maybe bring the eggs or larvae hookworm and *S.stercoralis* from hill to village and field rice. Potential infected together via field rice and rubber and palm plantations adult communities also for children when they were playing around houses.

Having dog was risk factor for hookworm, *S. stercoralis* and Co-infection, but highest risk factor for *S. stercoralis* (OR=4.42), This research has similarly condition with Cambodian research that dogs in rural Cambodian villages largely kept as guard dogs and allowed to roam freely, especially during the day. The dogs





the 5<sup>th</sup> ICTROPS

International Conference  
for Tropical Studies and Its Applications

Islamic Development Bank 4in1 Project  
Project Implementation Unit  
University of Mulawarman



IsDB  
البنك الإسلامي للتنمية  
Islamic Development Bank



are also allowed inside the house and around rice and vegetable fields and ponds. At night-time, the dogs then often stay in or around the house. Dogs, therefore, pose a serious zoonotic risk as they have the potential to transmit zoonotic parasites through their close association with household members as well as through heavy contamination of the environment, including soil, fresh produce and waterways, with eggs or larvae of hookworm and *S. stercoralis*, in our observation sew behavior of cats almost all day and night stayed around houses and rare contact with ponds and did not stay around rice and vegetable fields, behavior of dog is higher potential risk of zoonotic diseases of hookworm and *S. stercoralis* than behavior of cat (Schar F, et al, 2014 and Strkolcova G, et al 2017). Behavior of cat defecation make un-save survive of the egg or larvae of *S. stercoralis*

In the study was showed that live together with human infected with hookworm/*S. stercoralis*/Co-infection high risk for them but higher for *S. stercoralis* (OR=16.74) and co-infection (OR=14.78) than hookworm infection (OR= 1.37). In this study showed participants who positive *S. stercoralis* infection has live together with other positive *S. stercoralis* infection through one household or neighbor where live close were dominant, same as environmental risk factor, personal hygiene and sanitation facilities became caused together infection. Ecological risk factors have significant correlation with high prevalence of *S. stercoralis* such as district, humidity, temperature, volume and amount day of rain organic carbon of soil, texture of soil and elevation, the ecological risk factors make survive of infective larvae of *S. stercoralis* infection had explained with Garcia (2007) that a significant increase the prevalence of *S. stercoralis* infection with environmental conditions. Changing environmental conditions, specifically deforestation and subsequent silting of locally river, have caused periodic flooding with deposition on layer of sandy loam topsoil could increase soil moisture, and supporting by low quality of sanitation facilities and hygiene personal to add the increasing of *S. stercoralis* infection. These conditions, all of which are conducive to *S. stercoralis* transmissions, have allowed *S. stercoralis* infection to re-emerge as an important human pathogen in this area (Forrer, et al 2018).

## Conclusions

Ecological risk factors have significant correlation and high odd ratio of prevalence of hookworm , *S. stercoralis* and co- infection such as district, humidity, temperature, volume and amount day of rain organic carbon of soil, elevation, having dog and addition of risk factor is supported by low hygiene and sanitation, and live together with human infected by infected by hookworm infection and/or *S. stercoralis* infection in rural area of Kutai Kertanegara Regency. Essential environmental risk factors of the infections should use for preventing program of reduction prevalence hookworm and *S. stercoralis* infection.

## Acknowledgement

We grateful to participants and local authorities of Muarakaman District and Marangkayu District, Kutai Kertanegara Regency. We deeply thank the Dean of School of Public Health Mulawarman University for giving us the permission to use the laboratory and supporting approval of letter for this research. This work was supported by Walailak University grant (contract no 17/2561) and IsDB Project for funding Research in 2021.

## References

- Anamnart W, Pattanawongsa, A. Maleewong, P. Intapan., Morakote N, Janwan., P. Maleewong., W (2013). Detrimental Effect of Water Submersion of Stools on Development of *Strongyloides stercoralis*. PLoS ONE 8, e82339.
- Anamnart, W. Pattanawongsa A. Intapan P.M. and Maleewong W. (2010). Albendazole Stimulates the Excretion of *Strongyloides Stercoralis* Larvae in Stool Specimens and Enhances Sensitivity for Diagnosis of Strongyloidiasis. Journal of Clinical Microbiology, 48, 4216–4220
- Bethony J, Brooker S, Albonico M, Geiger SM, Loukas A, Diemert D & Hotez PJ. (2006). Soil-Transmitted Helminth Infections: Ascariasis, Trichuriasis, and Hookworm. Lancet 367, 1521-1532
- Boonjarasspinyo S, Boonmars T, Kaewsamut B, Ekobol N, Laummaunwa P, Aukkanimart R, Wonkchalee N, Juasook A, Sriraj P (2013). A Cross-Sectional Study on Intestinal Parasitic Infection in Rural Communities, Northeast Thailand. Korean J Parasitol Vol 51, No 6:727-734
- Forrer A, Khieu V, Schar F, Vounatsau P, Chammartin F, Marti H, Muth S, Odermatt P (2018). *Strongyloides stercoralis* and hookworm co-infection: spatial distribution and determinants in Preah Vihear Province, Cambodia. Parasit Vectors (2018) 11:33
- Garcia, Lynne Shore, (2007), Diagnostic Medical Parasitology, ASM Press Washington D.C Fifth Edition Chapter 10, 266-270
- Hall A, Conway DJ, Anwar KS & Rahman ML. (1994). *Strongyloides stercoralis* in an Urban Slum Community in Bangladesh: Factors Independently Associated with Infection. Trans R Soc Trop Med Hyg 88, 527-530
- Katz N, Chaves A & Pellegrino J. (1972). A Simple Device for Quantitative Stool Thick-Smear Technique in *Schistosomiasis mansoni*. Rev Inst Med Trop Sao Paulo 14, 397-400.
- Khieu V, Schär F, Marti H, Bless PJ, Char MC, Muth S & Odermatt P. (2014). Prevalence and Risk Factors of *Strongyloides stercoralis* in Takeo province, Cambodia. Parasit Vectors 7, 221.15
- Khieu V, Schär F, Marti H, Sayasone S, Duong S, Muth S & Odermatt P. (2013). Diagnosis, Treatment and Risk Factors of *Strongyloides stercoralis* in Schoolchildren in Cambodia. PLoS Negl Trop Dis 7, e2035.
- Kitvatanachai S, Pipitgool V (1999) Efficacy of three methods in the detection of hookworm and *Strongyloides stercoralis* infections. J Trop Med Parasitol 22: 80–81.
- Koga K, Kasuya S, Khamboonruang C, Sukhavat K, Ieda M, Takatsuka N, Kita K & Ohtomo H. (1991). A Modified Agar Plate Method for Detection of *Strongyloides stercoralis*. Am J Trop Med Hyg 45, 518-521.
- Naves and Costa-Cruz. (2013). High prevalence of *Strongyloides stercoralis* infection Among The Elderly in Brasil. Rev. Ins. Med. Trop Sao Paulo 55 (5) 309-313
- Prasit Na-Ek, Oranuch Sanpool, Jurairat Jongthawin, Witthaya Anamnart, Pewpan M. Intapan Pennapa Chamavit, Wanchai Maleewong (2016). Restoration of Hookworm Egg Development After Prolonged Storage in Stool Suspension. Parasitol Res 115, 2817–2823

Peter Steinmann, Peiling Yap, Jürg Utzinger, Zun-Wei Du, Jin-Yong Jiang et al (2015). Control of soil-transmitted helminthiasis in Yunnan province, People’s Republic of China: Experiences and lessons from a 5-year multi-intervention trial. *Acta Tropica* 141, 271–280

Strkolcova G, Goldova M, Bockova F, Mojzisova J.(2017) The roundworm *Strongyloides stercoralis* in children, dogs and soil inside and outside a segregated settlement in Eastern Slovakia: frequent but hardly detectable parasite. *Parasitol Res* DOI 10.1007/s00436-016-5362-1

Wardell R, Clements ACA, Lal A, Summers D, Llewellyn S, Campbell SJ, et al. (2017) An environmental assessment and risk map of *Ascaris lumbricoides* and *Necator americanus* distributions in Manufahi District, Timor-Leste. *PLoS Negl Trop Dis* 11(5)

Youthanavanh Vonghachack, Somphou Sayasone, Dalouny Bouakhasith, Keoka Taisayavong, Kongsap Akkavong, Peter Odermatt. (2015) Epidemiology of *Strongyloides stercoralis* on Mekong Islands in Southern Laos. *Acta Tropica* 141, 289–294.

Olsen A, van Lieshout L, Marti H, Polderman T, Polman K, Steinmann P, Stothard R, Thybo S, Verweij JJ & Magnussen P. (2009). Strongyloidiasis- -The Most Neglected of The Neglected Tropical Diseases? *Trans R Soc Trop Med Hyg* 103, 967-972

Khieu V, Schar F, Forrer A, Hattendorf, Marti, Duong S, Vounatsou P, Muth s, Odermatt P, High Prevalence and Special Distribution of *Strongyloides stercoralis* in Rural Cambodia. *Plos negl trop dis* 2014,; 8 e2854

Jongwutiwes S, Charoenkom M, Sitthichareonchai P, Akaraborvorn P, Putaportip,c, Increased Sensitivity of Routine Laboratory Detection of *Strongyloides stercoralis* and Hookworm by Agar-Plate Culture. *Trans R Soc Trop med Hyg*, 1999; 93: 398-400

Siddiqui AA & Berk SL. (2001). Diagnosis of *Strongyloides stercoralis* Infection. *Clin Infect Dis* 33, 1040-1047

## Tables and Figures

**Table 1 Prevalence of Hookworm, *Strongyloides stercoralis* and Co-infection among Communities in Kutai Kertanegara Regency**

Infections	Muarakaman District		Marangkayu District		Total	
	Positive	Negative	Positive	Negative	Positive	Negative
Hookworm	116 (61.1%)	74 (38.9%)	70 (37.6%)	166 (70.3%)	186 (43.7%)	240 (56.3%)
<i>S. stercoralis</i>	6 (3.2%)	184 (96.8%)	28 (11.9%)	208 (88.1%)	34 (8.0%)	392 (92%)
Co-infection	6 (3.2%)	184 (96.8%)	24 (10.2%)	212 (89.8%)	30 (7.0%)	396(93.0%)

**Table 2 Environmental Factors and *S. stercoralis* Infection in Kutai Kertanegara Regency**

Variable	Category	<i>S. stercoralis</i>		<i>P value</i>
		Negative n (%)	Positive n (%)	
District	Muarakaman	184 (96.8)	6 (3.2)	0.001
	Marangkayu	208 (88.1)	28 (11.9)	
Organic carbon content in soil	<2.47%	156 (85.7)	26(14.3)	0.000
	2.47-4.04%	236 (96.7)	8 (3.3)	



the 5<sup>th</sup> ICTROPS

International Conference  
for Tropical Studies and Its Applications

Islamic Development Bank 4in1 Project  
Project Implementation Unit  
University of Mulawarman



IsDB  
البنك الإسلامي للتنمية  
Islamic Development Bank



pH soil	<5.85	190 (93.1)	14 (6.9)	0.414
	5.85-6.92	202 (91.0)	20 (9.0)	
Clay content in soil	<18.5	178 (92.7)	14 (7.3)	0.634
	18.5-42.50	214 (91.5)	20 (8.5)	
Temperature	<28.6 °C	208 (88.1)	28 (11.9)	0.001
	28.6 -29.5°C	184 (96.8)	6 (3.2)	
Humidity	<65.4	208 (88.1)	28 (11.9)	0.001
	65.4-66	184 (96.8)	6 (3.2)	
Number day of rainfall	<164	184 (96.8)	6 (3.2)	0.001
	164-174	208 (88.1)	28 (11.9)	
Rainfall volume	<3549 mm <sup>3</sup>	184 (96.8)	6 (3.2)	0.001
	3549-4000 mm <sup>3</sup>	208 (88.1)	28 (11.9)	
Elevation from above of sea	<41.6m	188 (96.9)	6 (3.1)	0.001
	41.6-50m	204 (87.9)	28 (12.1)	
Texture of soil	Sandy soil with organic material	250 (89.9)	28 (10.1)	0.029
	Non-sandy soil with organic material	142 (95.9)	6 (4.1)	
Vegetation	Surrounding palm plantation and/or rubber plantation	310 (92.8)	24 (7.2)	0.248
	Surrounding rice field	82 (89.1)	10 (10.9)	
Village areas	Buffer river/sea	308 (92.8)	24 (7.2)	0.282
	Hill area	84 (89.4)	10 (10.6)	
Dry or wet soil surrounding house	Dry soil	308 (91.1)	30 (8.9)	0.182
	Wet soil	84 (95.5)	4 (4.5)	
Having cat	Not having cat	150 (93.8)	10 (6.3)	0.306
	Having cat	242 (91.0)	24 (9.0)	
Having dog	Not having dog	8 (100)	0 (0.0)	0.400
	Having dog	384 (91.9)	34 (8.1)	
<i>S. stercoralis</i> in cat	Negative	248 (92.5)	20 (7.5)	0.607
	Positive	144 (91.1)	14 (8.9)	
<i>S. stercoralis</i> in dog	Negative	102 (98.1)	2 (1.9)	0.009
	Positive	290 (90.1)	32 (9.9)	
Live together with human infected with <i>S. stercoralis</i>	No	386 (99.5)	2 (0.5)	0.000
	Yes	6 (15.8)	32 (84.2)	

**Table 3 Essential Risk Factors of *S. stercoralis* in Kutai Kertanegara Regency**

Essential risk factors	Category	<i>S. stercoralis</i>		OR (95%CI)
		Negative n (%)	Positive n(%)	
District	Muarakaman	184 (96.8)	6 (3.2)	0.64 (0.54-0.77)
	Marangkayu	208 (88.1)	28 (11.9)	2.66 (1.28-5.54)
Organic carbon content in soil	<2.47%	156 (85.7)	26 (14.3)	2.56 (1.38-4.71)
	2.47-4.04%	236 (96.7)	8 (3.3)	0.52 (0.45-0.65)
Temperature	<28.6 °C	208 (88.1)	28 (11.9)	2.66 (1.28-5.54)
	28.6 -29.5°C	184 (96.8)	6 (3.2)	0.64 (0.54-0.77)
Humidity	<65.4	208 (88.1)	28 (11.9)	2.66 (1.28-5.54)
	65.4-66	184 (96.8)	6 (3.2)	0.64 (0.54-0.77)



the 5<sup>th</sup> ICTROPS

International Conference  
for Tropical Studies and Its Applications

Islamic Development Bank 4in1 Project  
Project Implementation Unit  
University of Mulawarman



IsDB  
البنك الإسلامي للتنمية  
Islamic Development Bank



Number day of rainfall	<164	184 (96.8)	6 (3.2)	0.64 (0.54-0.77)
	164-174	208 (88.1)	28 (11.9)	2.66 (1.28-5.54)
Rainfall volume	<3549 mm <sup>3</sup>	184 (96.8)	6 (3.2)	0.64 (0.54-0.77)
	3549-4000 mm <sup>3</sup>	208 (88.1)	28 (11.9)	2.66 (1.28-5.54)
Elevation from above of sea	<41.6m	188 (96.9)	6 (3.1)	0.63 (0.53-0.76)
	41.6-50m	204 (87.9)	28 (12.1)	2.72 (1.30-5.66)
Texture of soil	Sandy soil with organic material	250 (89.9)	28(10.1)	2.05 (0.98-4.29)
	Non-sandy soil with organic material	142 (95.9)	6 (4.1)	0.77 (0.66-0.92)
<i>S. stercoralis</i> in dog	Negative	102 (98.1)	2 (1.9)	0.78 (0.71-0.87)
	Positive	290 (90.1)	32 (9.9)	4.42 (1.14-17.15)
Occupation	Non farmer	248 (89.9)	28 (10.1)	2.08 (0.99-4.35)
	Farmer	144 (92)	6 (4.0)	0.77 (0.65-0.99)
Live together with human infected with <i>S. stercoralis</i>	No	386 (99.5)	2 (0.5)	0.16 (0.01-0.03)
	Yes	6 (15.8)	32 (84.2)	16.74 (4.36-64.22)

**Figure 1.** Modified agar plate techniques. (a; *Strongyloides stercoralis* filariform larva (L3), b; *Strongyloides stercoralis* filariform larva (L3) ,c) *Strongyloides stercoralis* rhabditiform larva (L2). Microscopic observation under low power (x10).

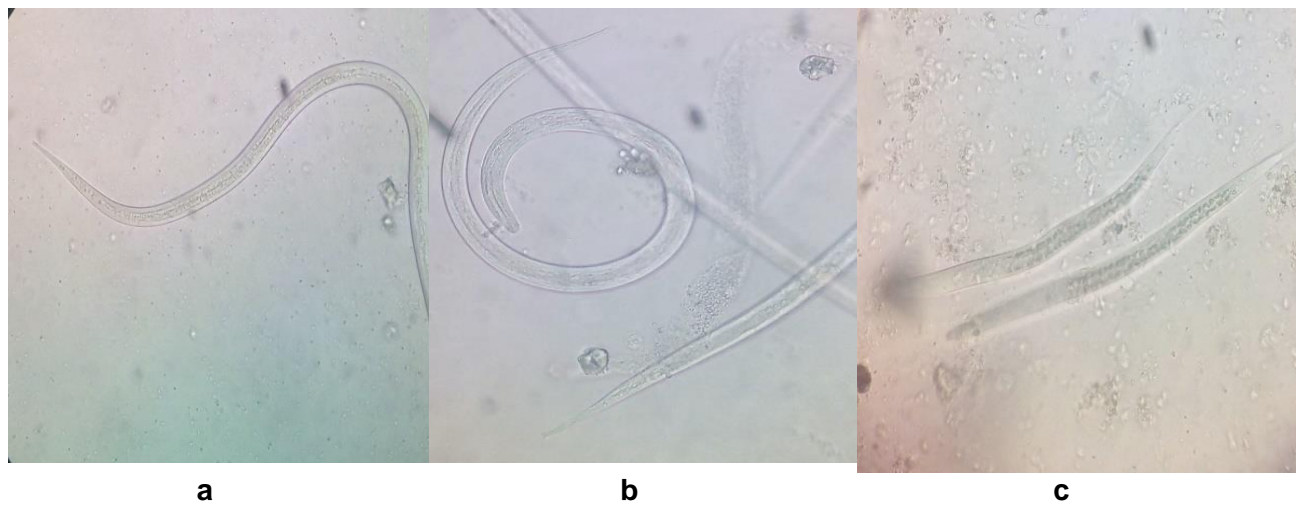

## TEE-436

### Association of Endophytic Fungi in Rice Root (*Oryza sativa L*)

Sopialena 1\* , Ni'matuljannah 2 , and Devi Tantiani 3

Program of Plant Pest Disease Science, Faculty of Agriculture, Mulawarman University, Pasir Balengkong  
Street, Gunung Kelua, Samarinda, East Kalimantan, Indonesia.

Corresponding Author\* : [sopialena88@gmail.com](mailto:sopialena88@gmail.com)

#### Abstract

The aim of this research was to elaborate the association of endophytic fungi found in the root tissue of rice plants (*Oryza sativa*). The sampling location was in Sungai Kapih Village, Sambutan District, Samarinda City. This research was conducted at the Plant Disease Pest Science Laboratory, Faculty of Agriculture, Mulawarman University. The method used in this study were staining the roots of rice plants and observing endophytic fungi in the root tissue of rice plants under the microscope. The results showed that the root tissue formed hyphae and spores in the root cortex. The hyphae that were found had hyphae that were neither insulated nor insulated, forming long chains with spherical spores. In the roots of the control plants, there were no endophytic fungi that formed colonies in the root tissue.

**Keywords:** endophytic fungi, rice, association

#### Introduction

Farmers generally use pesticides excessively in controlling plant diseases without paying attention to natural enemies around the crop. The use of pesticides is carried out without taking into account the damage caused such as the occurrence of pest resistance to pesticides, pest resurgence and the death of natural enemies, damaging human health and the environment, the presence of residues in agricultural products, the emergence of new biotypes that are more resistant, and the death of biota that make up ecological habitats. not the target (Kartohardjono 2011).

Control of Plant Pest Organisms (OPT) which is commonly carried out today is control using synthetic pesticides, this happens because farmers think this control is very easy to do and produces more effective results. Control using synthetic pesticides is proven to be detrimental to humans and the agro-ecosystem environment. Environmentally friendly control is the answer to the problem of synthetic pesticides, many natural ingredients can be used as raw materials in the manufacture of biological pesticides. One of the potential raw materials for control using biological pesticides is endophytic fungi. According to (Sopialena 2020) endophytic fungi on rice plants are able to become biological agents to control pests and diseases in plants.

Endophytic fungi are fungi that live in certain tissues that are able to produce mycotoxins, enzymes and antibiotics so that their presence will be beneficial for the host plant because it increases

resistance and uptake of nutrients in the soil. Compounds produced by endophytic fungi can be potential as biological controllers.

Several studies on endophytic fungi that have the potential as biological control have been carried out, but not many studies related to observe the associations of endophytic fungi on plant roots after inoculation. This study proved that endophytic fungi can be invested through the roots of tomato plant.

## MATERIALS AND METHODS

The location of the research was carried out at the Laboratory of Plant Pests and Diseases, Faculty of Agriculture, Mulawarman University, Samarinda. The samples of tomato roots were taken from the field in Sambutan District, Samarinda City.

### Research procedure

#### a. Field Research

The field research used a 5 x 3 factorial study with 5 replications arranged with a Split Plot Design. The treatments in this study are:

Endophytic Fungus as Main Plot with 5 levels

C1 : *Control*

C2 : *Trichoderma* sp.

C3 : *Rhizopus* sp.

C4 : *Gliocladium* sp.

C5 : *Penicillium* sp.

Varieties as Sub-plots with 3 levels, are:

V1 : Ciherang

V2 : Kambang

V3 : Pandan Ungu

Endophytic fungus inoculation was carried out on the rice planting medium soil before transplanting. Root samples were taken from plants that had been harvested.

#### b. Staining of Rice Plant Roots

Root staining was carried out to see the structure and number of fungi present in the plant root tissue so as to facilitate the observation and determination of fungal infections on rice plants. Root staining in this study used the method used by (Brundrett et al. 1996) with a dye solution that had been modified with safranin and 5% methylene blue. The rice roots are cleaned with running water and put in a container. The clean rice roots are then processed sequentially by clearing and staining. Clearing was done by soaking the roots in 10% KOH solution and heated at a temperature of 60oC to 70oC for 30 minutes, then washed with distilled water until the roots were clear. After that soak using alcohol

for 1 minute and wash again with distilled water. The root staining stage was carried out in 2 stages, namely soaking using safranin for 4 hours, sterilizing with alcohol for 1 minute and washing with distilled water. Furthermore, for the second staining is done by immersion using methylene blue according to the previous staining process.

**c. Observation of Endophytic Fungus on Rice Root Tissue**

Root samples observed were treated roots after harvest without inoculation of pathogens and after inoculation of pathogens. This was done to see the effect of endophytic fungi on the ability of biocontrol agents. The stained root samples were cut 1 cm long and placed on a glass slide. Roots were observed under a microscope using optilab as a tool for taking documentation. The appearance of the structure of hyphae and spores is an indication that the root has been colonized by endophytic fungi found in the root cortex..

**RESULTS AND DISCUSSION**

Based on microscopic observations, endophytic fungi are present in roots by forming hyphae on the root cortex and releasing spores. The hyphae were found to have neither insulated nor insulated hyphae, forming a long chain with spherical spores. No endophytic fungi were found in the

roots of the control plants that formed colonies in the root tissue. The results of the observations can be seen in table 17.

Table 17. Endophytic Fungi on Roots of Rice Plants var. Ciherang, Kambang and Purple Pandan in every treatment

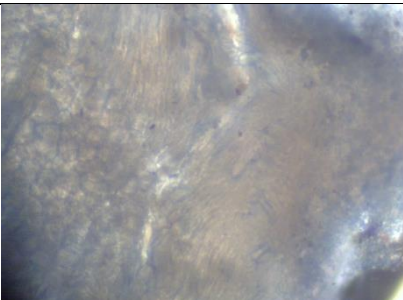
	Varieties	reatment	Documentation
	Ciherang	Control	





the 5<sup>th</sup> ICTROPS

International Conference  
for Tropical Studies and Its Applications

Islamic Development Bank 4in1 Project  
Project Implementation Unit  
University of Mulawarman



IsDB  
البنك الإسلامي للتنمية  
Islamic Development Bank

Co-Organized by :



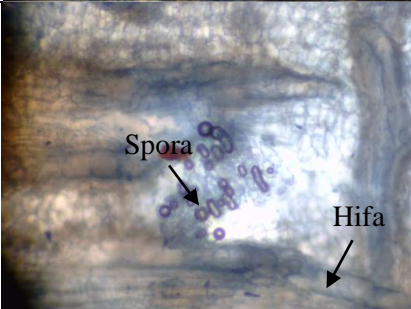
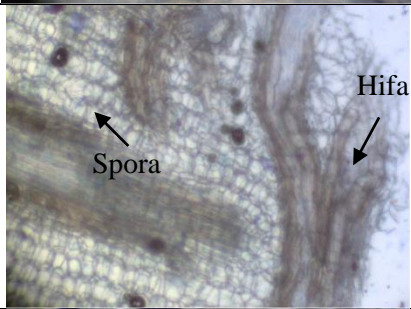
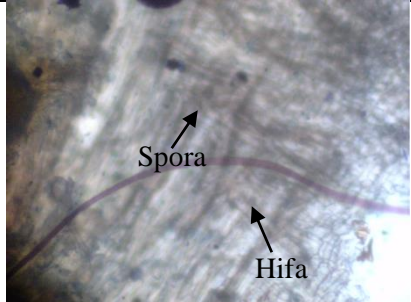

		<i>Trichoderma</i> sp.		
		<i>Rhizopus</i> sp.		
		<i>Gliocladium</i> sp.		
		<i>Penicillium</i> sp.		



the 5<sup>th</sup> ICTROPS

International Conference  
for Tropical Studies and Its Applications

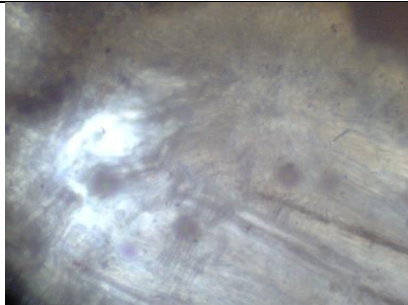

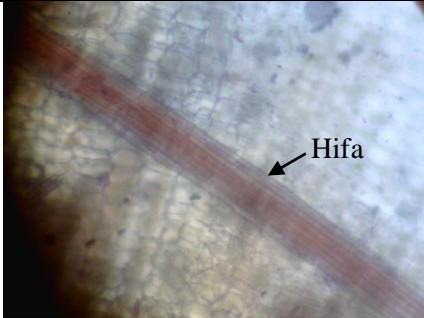
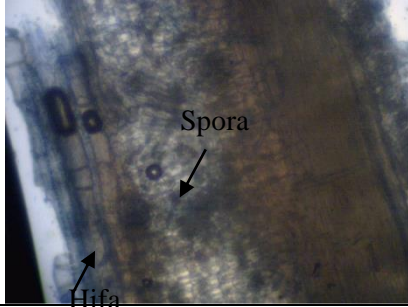
		Control		
Kambang		<i>Trichoderma</i> sp.		
		<i>Rhizopus</i> sp.		
		<i>Gliocladium</i> sp.		



the 5<sup>th</sup> ICTROPS

International Conference  
for Tropical Studies and Its Applications



Co-Organized by :



		<i>Penicillium</i> sp.		
		Control		
Pandau Ungu		<i>Trichoderma</i> sp.		
		<i>Rhizopus</i> sp.		



the 5<sup>th</sup> ICTROPS

International Conference  
for Tropical Studies and Its Applications

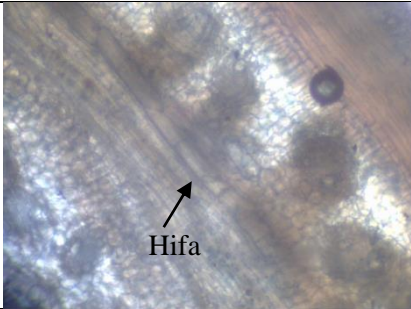
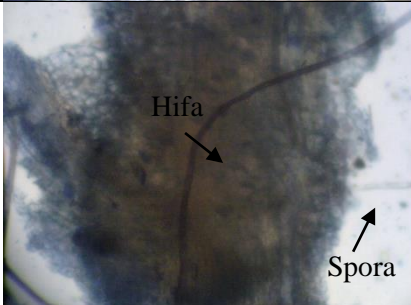

		<i>Gliocladium</i> sp.		
		<i>Penicillium</i> sp.		

In the control treatment of the Ciherang, Kambang and Pandan Ungu varieties, it could be seen that the roots were not colonized by endophytic fungi because there were no hyphae or spore structures visible. The results of root staining in all treatments proved the presence of endophytic fungus colonization in symbiosis with rice plant roots. The hyphae seen in the Ciherang variety treated by *Trichoderma* sp. showed the presence of uninsulated hyphae and seen pyramids, but in the Kambang and Pandan Ungu varieties, only uninsulated hyphae were seen with round spores. This refers to the results of research conducted by (Suanda 2019) which suggests that microscopic *Trichoderma* sp. have uninsulated hyphae. In a study conducted by (Sugiyarto, Umniyatie, and Henuhili 2016) found that *Trichoderma* sp. in plant tissue to form hyphae that are not insulated with some forming a pyramid.

(Sopialena 2017) The life cycle of a pathogen starts from growing to producing reproductive organs. The entry cycle of fungi into plants includes fungal changes in the plant body and a series of changes in the host plant and the presence of pathogens (pathogenic life cycle) in it within a certain time span during the plant growth period. Important events in this cycle include: inoculation (transmission), penetration (entering the body), infection (utilization of host nutrients), invasion (expansion of attack to other tissues), spread to other sites and pathogen defense.

Fungal inoculation, the inoculum can be in the form of mycelium, spores, or sclerotium. the

steps that occur in the inoculation process, starting from: the inoculum of the pathogen to the surface of the host plant's body, To perform germination an appropriate temperature and humidity are needed in the form of a layer of water on the plant surface. The wet state or form of this water film must last



## the 5<sup>th</sup> ICTROPS

International Conference  
for Tropical Studies and Its Applications

Islamic Development Bank 4in1 Project  
Project Implementation Unit  
University of Mulawarman



IsDB  
البنك الإسلامي للتنمية  
Islamic Development Bank



long enough for the inoculum to enter or penetrate into cells or tissues. Penetration of these endophytic fungi directly penetrates the surface of the plant body, through natural holes, through wounds, and through intermediaries (carriers, vectors). Fungi exploit every possible pathway to gain entry to their hosts, although individual fungal species tend to have a preferred method. Fungal pathogens often use direct penetration of plant surfaces to enter the host. This requires adhesion to the plant surface, followed by application of pressure and then enzymatic degradation of the cuticle and cell wall, to overcome the physical barriers presented by the plant surface. During cuticle and wall degradation, gene switching is switched on and off in fungi, so cutinase, followed by cellulase, then pectinase and proteases are produced, attack the cuticle, cell wall, and middle lamella in sequence. That they were encountered The pressure required for the hyphae to penetrate the cell wall was achieved by first attaching the appressorium to the plant surface with a protein adhesive. The cell wall of the appressorium is then impregnated with melanin, making it impermeable to water, and able to withstand the high turgor pressure that builds up inside the appressorium. The nucleus of the appressorium in contact with the cuticle is called the penetration pore, and its walls are thinnest at this point. The increased turgor pressure causes the pores to herniate, forming penetrating pegs, which apply great pressure to the host cuticle and cell walls. An alternative route for the entry of the fungus is through an opening that is already on the surface of the plant. This could be a natural opening or a wound.

Furthermore, the fungus goes through an infection process which is a process of starting the pathogen utilizing nutrients ('food extract') from the host. This process occurs after the pathogen makes contact with susceptible cells or tissues and obtains nutrients from these cells or tissues. During the infection process, the pathogen will grow and develop in the plant tissue. Infection that occurs in the host plant, will produce symptoms of the disease that appear from the outside such as: yellowing, changing shape (malformation), or spotting (necrotic). However, infection by endophytic fungi will not cause disease symptoms in plants, because these endophytic fungi are fungi that are very able to associate well with plants, where plants can tolerate the presence of endophytic fungi and do not cause plants to get sick. After the fungus infects the plant tissue, the fungus will then invade, which is the stage of growth and development of the fungus after infection. This process is the spread of fungi from one cell to another in the host plant tissue. Then carry out the process of colonization or the formation of more than one individual fungus.

In the treatment of *Rhizopus* sp., both varieties of Ciherang, Kambang, and Pandan Ungu showed uninsulated hyphae with round spores, but no sporangiophores were seen on observation. In the observed root tissue, many hyphae were colonized, so it was evident that the treatment using *Rhizopus* sp. effective in increasing plant resistance. This is in accordance with the statement (Izzati, Lubis, and Hasanuddin 2019) which states that *Rhizopus* sp. is an endophytic fungus that is able to associate with plants through roots to increase plant resistance and prevent disease attacks.

Treatment of *Gliocladium* sp. on Ciherang, Kambang and Pandan Ungu varieties showed that *Gliocladium* sp. form insulated hyphae with spherical spores. The appearance of hyphae in all treatments of this fungus proved that this fungus was able to associate well with plants and was able to colonize well on plant roots. In a study conducted (Herlina 2013) suggested that *Gliocladium* sp. have hyphae that are insulated by forming a pyramid as in *Trichoderma* sp. and this fungus is also able



## the 5<sup>th</sup> ICTROPS

International Conference  
for Tropical Studies and Its Applications

Islamic Development Bank 4in1 Project  
Project Implementation Unit  
University of Mulawarman



IsDB  
البنك الإسلامي للتنمية  
Islamic Development Bank



to associate with plants by colonizing plant parts. While in the treatment of *Penicillium* sp. un-insulated hyphae structure was seen in Ciherang, Kambang and Pandan Ungu varieties. Colonization of the fungus *Penicillium* sp. can be seen very clearly in the cross section of the observed rice plant roots. The observed results are in accordance with the microscopic morphology

seen in research conducted by (Assaf et al. 2020) which also shows the morphological structure of hyphae that are not insulated and have secondary metabolites that are able to prevent disease attacks.

From all observations, the microscopic morphology of hyphae was in accordance with the identification observations of each of the characteristics of endophytic fungi that grew intracellularly in root cortical cells. Colonization that occurs in roots begins with the penetration of endophytic fungi into the epidermis and cortex tissue, then colonizes intracellularly and reproduces itself in these tissues and then spreads to other root tissues. In a study conducted by (Fitriani, Wiyono, and Sinaga 2020) endophytic fungi were found in the epidermal and cortical tissues that colonize intracellularly. This proves that the endophytic fungi that were applied were able to associate well with plants by colonizing the roots, whereas in plants that were not treated with endophytic fungi, hyphae structures were not visible in the root tissue. The endophytic fungus colonization and the reduced intensity of disease in plants treated with endophytic fungi showed that the symbiosis between endophytic fungi and plants was very good so that the suppression of blast disease in rice plants could be maximized.

## CONCLUSION

From the results of the study, it can be concluded that there is an association of endophytic fungi invested in the root tissue of rice plants

## REFERENCES

- Assaf, Christelle El Hajj, Chrystian Zetina-Serrano, Nadia Tahtah, André El Khoury, Ali Atoui, Isabelle P. Oswald, Olivier Puel, and Sophie Lorber. 2020. "Regulation of Secondary Metabolism in the *Penicillium* Genus." *International Journal of Molecular Sciences*.
- Brundrett, M., N. Bougher, B. Dell, T. Grove, and N Malajczuk. 1996. *Working with Mycorrhizas in Forestry and Agriculture Mycorrhizas of Australian Plants View Project Banksia Woodland Restoration Project View Project*.
- Fitriani, Mei Lita, Suryo Wiyono, and Meity Suradji Sinaga. 2020. "Potensi Kolonisasi Mikoriza Arbuskular Dan Cendawan Endofit Untuk Pengendalian Layu *Fusarium* Pada Bawang Merah." *Jurnal Fitopatologi Indonesia* 15 (6): 228–38.
- Herlina, Lina. 2013. "Uji Potensi *Gliocladium* Sp terhadap Pertumbuhan dan Produksi Tanaman Tomat." *Journal of Biology & Biology Education* 5 (2): 88–93.
- Izzati, Inni, Lahmuddin Lubis, and Hasanuddin. 2019. "Eksplorasi Cendawan Endofit pada Akar

- Tanaman Karet (*Hevea brasiliensis* Muell. ARG.) sebagai Agens Hayati Jamur Akar Putih (*Rigidoporus microporus* (Swartz; FR)) di Kabupaten Asahan.” *AGROEKOTEKNOLOGI* 7 (2): 347–55.
- Kartohardjono, Arifin. 2011. “Penggunaan Musuh Alami Komponen Pengendalian Hama Padi Berbasis Ekologi.” *Pengembangan Inovasi Pertanian*.
- Sopialena. 2017. *Segitiga Penyakit Tanaman*. Samarinda, Kalimantan Timur.
- Sopialena, Sopian dan Lusyana Dwi Allita. 2020. “Diversitas Jamur Endofit Pada Tanaman Padi (*Oryza Sativa* L.) Dan Potensinya Sebagai Pengendali Hama Endophytic Fungi Diversity in Rice Plant and Their Potential as Pest Control” 2: 105–10.
- Suanda, I Wayan. 2019. “Karakterisasi Morfologis *Trichoderma* sp. Isolat JB dan Daya Hambatnya terhadap Jamur *Fusarium* Sp. Penyebab Penyakit Layu dan Jamur Akar Putih Pada beberapa Tanaman.” *Widya Biologi* 10 (9): 1689–99.
- Sugiyarto, Lili, Siti Umniyatie, and Victoria Henuhili. 2016. “Keanekaragaman Anggrek Alam Dan Keberadaan Mikoriza Anggrek Di Dusun Turgo Pakem , Sleman Yogyakarta the Diversity of Orchid Mycorrhiza Existence in Turgo Village.” *Sains Dasar*.

## TEE-444

### Effect of UVA, UVC, UVA/TiO<sub>2</sub>, and UVC/TiO<sub>2</sub> for Degrading Synthetic Dyes

**Nurul Novalia Kartika, Fahrizal Adnan\*, Ika Meicahayanti, Muhammad Busyairi**

Department of Environmental Engineering, Mulawarman University

*Corresponding Author\*: fahrizaladnan@ft.unmul.ac.id.*

#### Abstract

The purpose of this study was to determine the photolysis effect to methyl orange (MO) and then, role of TiO<sub>2</sub> photocatalyst. The synthesis of TiO<sub>2</sub> photocatalyst was carried out using the Sol-Gel method with a ratio of 3:1:4 between ethanol, titanium butoxide and DI Water. The degradation reaction of methyl orange was tested using a concentration of 5 ppm of MO solution. Sampling was carried out every 30 minutes for 5 hours. Then, tested using UV-VIS spectrophotometry with a wavelength along 464 nm. The results of photolysis of methyl orange dye were 14.17% and 12.62% for UVA and UVC, respectively. While, the degradation using UVC/TiO<sub>2</sub> and UVA/TiO<sub>2</sub> were 58.49% and 65.55%, respectively. pH variations and MO concentration were conducted. The optimum results at pH 7 were 37.08% and 27.33% for 10 ppm and 15 ppm, respectively.

**Keywords:** Photolysis, Photocatalyst, TiO<sub>2</sub>, UVA, UVC.

#### Introduction

The textile industry has been using synthetic dyes such as non-biodegradable azo dye. Azo dye was difficult or need longer time to biodegrade. The widely used azo dye is methyl orange (MO). Azo compounds were described as carcinogenic and mutagenic materials (Christina, 2007). Therefore, the need for the decolorization of azo dye has received increasing consideration to improve environmental protection.

Photocatalyst reaction consists of catalyst material that generates radicals when exposed to light illumination. Photocatalyst reaction are projected more effective to remove textile dye contaminants than adsorption and filtration processing methods. Photocatalysts is minor saturated due to radicals generation (Ferry, 2017).

Titanium dioxide (TiO<sub>2</sub>) is one of catalyst that well-known to be ideal photocatalyst due to chemically inert, stable and easy to synthesis. TiO<sub>2</sub> could generate radicals with illumination of specific wavelength of UV. UV plays as energy source to electron/hole reaction. Previous researchers found that radicals generation can happen in specific wavelength due to crystal phase of TiO<sub>2</sub>.

The degradation process of organic substances is dependent on pH (Sreekantan, 2010) due to the affinity between photocatalyst and pollutant. A previous study found that the photocatalytic degradation rate of MO by TiO<sub>2</sub> film was stable between a pH range of 4 to 9 However, other researchers reported that the degradation rate of MO at pH 9 was faster than at pH 5 to 7.

Therefore, this study was conducted to remove azo compounds (methyl orange) using UVA, UVC, UVA/TiO<sub>2</sub>,



and UVC/ TiO<sub>2</sub>. This research can be applied as an alternative to wastewater treatment containing azo dyes which are commonly used in the textile and clothing industry.

## Materials and Methods

The TiO<sub>2</sub> synthesis process begins with the synthesis of TiO<sub>2</sub> catalyst in powder form using the sol-gel method with a ratio of 3:1:4 between ethanol, titanium butoxide, and distilled water. The sol-gel method goes through four main processes, such as, hydrolysis, condensation process, aging and the drying.

This research was conducted using four black box 40 x 40 x 45 cm. Two boxes contain UVA lamps and two other boxes contain UVC lamps. In each box, two lamps were installed. The distance between the solution and the light was 8 cm. The methyl orange standard solution was made using 0.05 g of methyl orange powder which was diluted into 100 mL of distilled water to obtain a 500 ppm of methyl orange solution. Then a 5 ppm methyl orange solution was made in 500 mL of pH 7. Effect of UVA, UVC, UVA/TiO<sub>2</sub> and UVC/ TiO<sub>2</sub> were conducted. The effect of pH 3 and 10 were also studied. Then the variation of concentration of methyl orange 10 and 15 ppm was diluted with water at pH 7 which was reacted with UVA/TiO<sub>2</sub>. Sample was taken every 30 minutes for 5 hours. The samples were then tested using UV-VIS spectrophotometry with a wavelength of 464 nm.

## Results and Discussions

### Effect of UVA, UVC, UVA/TiO<sub>2</sub> and UVC/TiO<sub>2</sub>

Comparative analysis between the reactions that occur between the use of UVA, UVC, UVA/ TiO<sub>2</sub> and UVC/ TiO<sub>2</sub> were studied with degradation of 5 ppm methyl orange compounds in a pH 7 solution for 300 minutes during the photolysis process. Comparison of the degradation percentage of methyl orange between UVA light without TiO<sub>2</sub> and UVA light with 0.5 g of TiO<sub>2</sub> and the degradation percentage of methyl orange between UVC light without additional TiO<sub>2</sub> and UVC light with the addition of 0.5 g of TiO<sub>2</sub> shows in Figure 1 and Figure 2. Those figures show that the use of TiO<sub>2</sub> as a catalyst in the photolysis process is very influential in reducing the levels of methyl orange in the solution. In the UVA photolysis experiment without TiO<sub>2</sub>, it was only able to degrade methyl orange by 14.17%, while when 0.5 g of TiO<sub>2</sub> catalyst was added, the degradation ability increased to 65.55% for 300 minutes. This also happened in experiments using UVC light. Where the experiments carried out without the addition of TiO<sub>2</sub> were only able to degrade methyl orange by 12.63% while the addition of 0.5 g of TiO<sub>2</sub> catalyst was able to increase the photolysis reaction to 58.49% within 300 minutes. In UVA light with the addition of a TiO<sub>2</sub> catalyst, the degradation that occurs is much higher than the UVC photocatalyst reaction with a TiO<sub>2</sub> catalyst. Based on research conducted by Forseca-Cervantes (2020) regarding the band gap effect for TiO<sub>2</sub> photocatalyst, it was found that TiO<sub>2</sub> in the form of anatase is more suitable and able to react better to light with a wavelength of about 380 nm. It can be said that TiO<sub>2</sub> is able to react better to form hydroxyl radical compounds in UVA light where UVA light itself has a wavelength ranging from 315 - 400 nm.

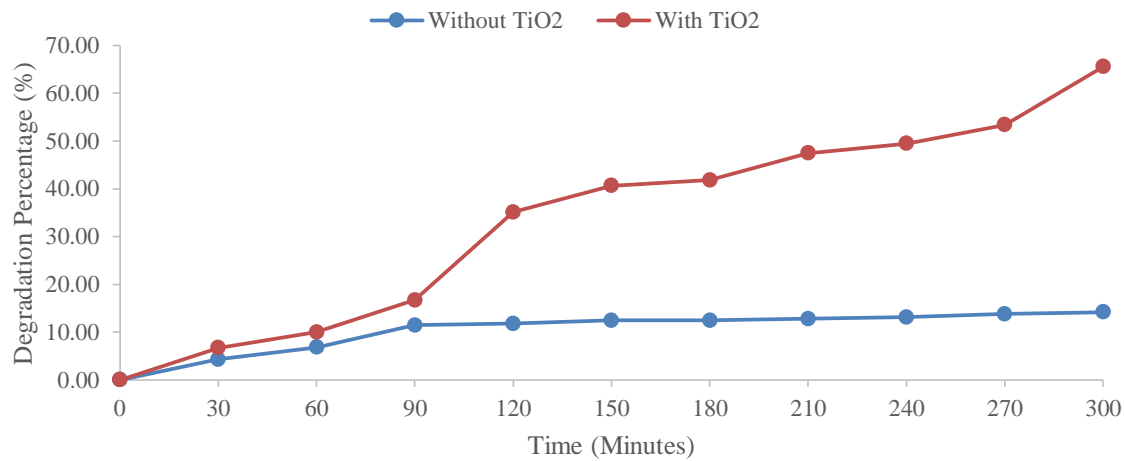

**Figure 1. Methyl Orange Degradation Percentage against UVA and UVA/TiO<sub>2</sub>**

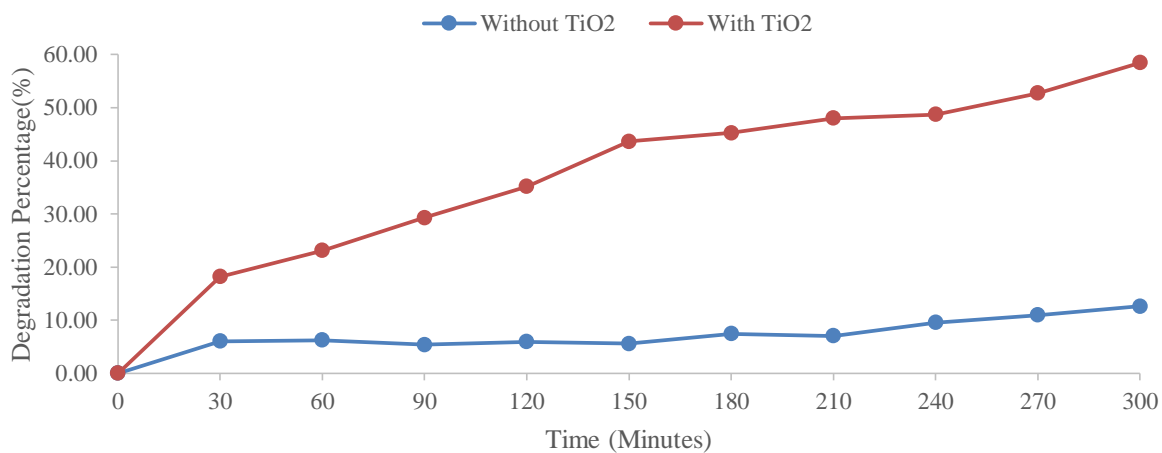

**Figure 2. Methyl Orange Degradation Percentage against UVC and UVC/TiO<sub>2</sub>**

In the reaction of TiO<sub>2</sub> with light waves, there has been a change in the OH<sup>-</sup> compounds in TiO<sub>2</sub> into radical compounds where these radical compounds will degrade methyl orange organic compounds in solution. Therefore, titanium dioxide (TiO<sub>2</sub>) is a catalyst that can accelerate the degradation reaction of methyl orange in the photolysis process.

### Effect of pH

Comparative analysis of the effectiveness that occurs between the use of pH variations, namely at acid, neutral, and alkaline levels in their ability to degrade methyl orange compounds in solution for 300

minutes during the photocatalyst process.

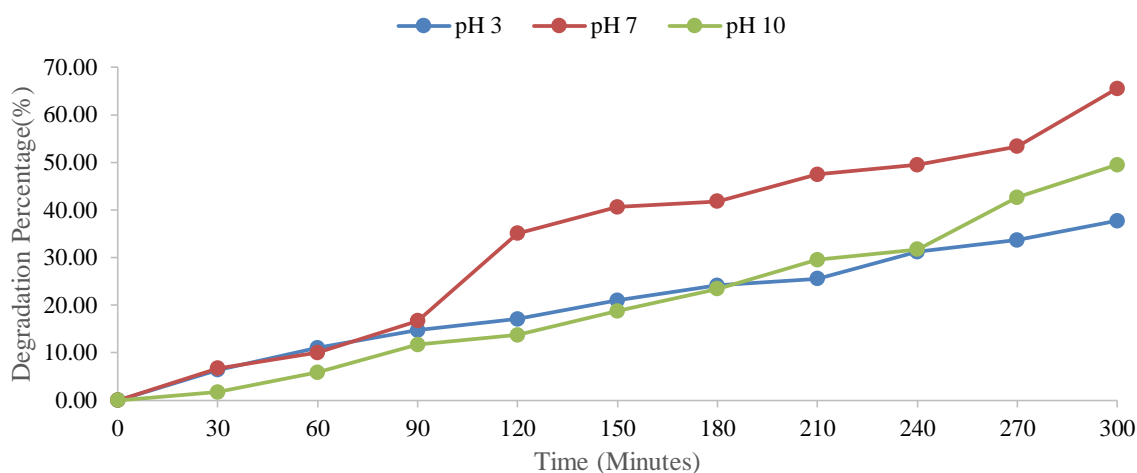

**Figure 3. Methyl Orange Degradation Percentage against pH 3, 7 and 10**

Comparison of the percentage of methyl orange degradation between methyl orange pH 3 solution, methyl orange pH 7 solution, and methyl orange pH 10 solution was carried out using a concentration of methyl orange of 5 ppm and the addition of 0.5 g of  $\text{TiO}_2$  which was then reacted in a storage box containing light. UVA. The graph of the percentage of degradation of methyl orange at pH 3, 7, and 10 can be seen through figure 3.

Based on figure 3 above, it can be seen that the use of pH 7 in methyl orange solution has the ability to degrade organic compounds greater than pH 3 and pH 10. It is known that in a pH 3 solution, the photocatalyst reaction is only able to degrade methyl orange by 37.70 % and in a solution of pH 10 the photocatalyst reaction was able to degrade methyl orange by 49.47%. Meanwhile, at pH 7, it was able to increase the degradation of  $\text{TiO}_2$  catalyst it was able to degrade methyl orange by 65.55%.

Based on Bilal (2019), the use of solvents and precursors in forming  $\text{TiO}_2$  affects the formation of  $\text{TiO}_2$  where it will affect particle size, particle surface area, and the optimum pH of the photocatalyst reaction that occurs in methyl orange solution. In this study, the optimum pH for methyl orange photocatalyst in a solution that has pH 7. This indicates that pH 7 in the solution can help  $\text{TiO}_2$  in forming its hydroxyl compounds so that it is able to degrade methyl orange compounds better than the hydroxyl compounds formed when  $\text{TiO}_2$  at a solution of pH 3 and pH 10.

### Effect of MO Concentrations

In UVA light with the addition of a  $\text{TiO}_2$  catalyst, the degradation that occurs is much higher than the UVC photocatalyst reaction with a  $\text{TiO}_2$  catalyst. Based on research conducted by Forseca-Cervantes (2020) regarding the band gap effect for  $\text{TiO}_2$  photocatalyst, it was found that  $\text{TiO}_2$  in the form of



the 5<sup>th</sup> ICTROPS

International Conference  
for Tropical Studies and Its Applications



anatase is more suitable and able to react better to light with a wavelength of about 380 nm. It can be said that  $\text{TiO}_2$  is able to react better to form hydroxyl radical compounds in UVA light where UVA light itself has a wavelength ranging from 315 - 400 nm.

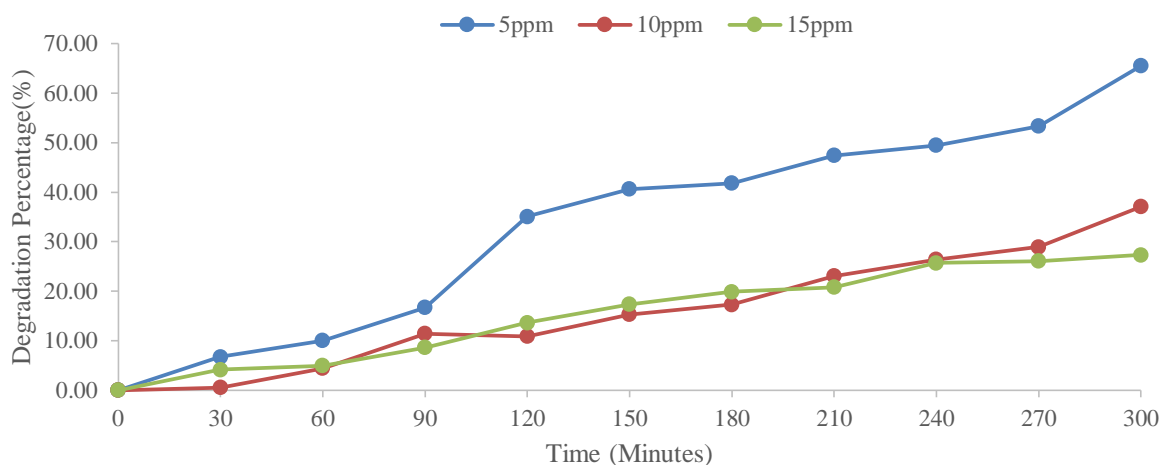

**Figure 4. The Percentage of Degradation of Methyl Orange pH 7 Concentrations of 5, 10, and 15 PPM by UVA/ $\text{TiO}_2$**

Comparative analysis between variations in the concentration of methyl orange at 5, 10, and 15 ppm was carried out to determine the effectiveness the use of 0.5 g which can degrade methyl orange solution in pH 7 with the help of UVA light. The comparison of effectiveness in this variation of methyl orange concentration can be seen in figure 4.

Based on figure 4, which is a comparison of the percentage of methyl orange degradation with variations in the concentration, it can be seen that the 0.5 g  $\text{TiO}_2$  photocatalyst under UVA light and an acidity level of pH 7 was able to properly degrade the concentration of methyl orange organic compounds with a concentration of 5 ppm up to 65.55%. When compared with the concentration variation of 10 ppm where the percentage level of degradation is only 37.08% and 27.33% at a concentration variation of 15 ppm, it can be said that UVA/  $\text{TiO}_2$  photocatalyst is the most efficient in degrading 5 ppm methyl orange. Based on Yuningrat (2015),  $\text{TiO}_2$  powder contains radical compounds that can degrade organic compounds. The radical compounds formed and the absorbance ability at 0.5 g of  $\text{TiO}_2$  tend to be the same, so it can be said that the smaller the concentration of methyl orange, the higher the percentage of degradation.

## Conclusions

The purpose of this study was to determine the photolysis that occurs in methyl orange and the

degradation of methyl orange using a TiO<sub>2</sub> photocatalyst with variations in UVA and UVC rays also variations in pH and the variations concentration of methyl orange.

The synthesis of TiO<sub>2</sub> photocatalyst was carried out using the Sol-Gel method with a ratio of 3:1 between ethanol and titanium butoxide and then a ratio of 1:1 between the precursor solution and DI water. To determine the photolysis reaction of methyl orange that occurs in UVA and UVC rays, which were tested using a concentration of 5 ppm in 500 mL of solution and pH 7 where sampling was carried out every 30 minutes for 5 hours. Then tested using UV-VIS spectrophotometry with a wavelength along 464 nm and the results of photolysis of methyl orange dye were 10.46% at UVA and 9.54% at UVC. While the degradation using UVC and UVA rays by adding 0.5 g of TiO<sub>2</sub>, obtained degradation results at UVC/ TiO<sub>2</sub> is 43.03% and 50.23% at UVA/ TiO<sub>2</sub>. Variations of pH 3 and 10 were carried out on a 500 mL solution of 5 ppm methyl orange using 0.5 g of TiO<sub>2</sub> under UVA light. This is due to the use of UVA light and 0.5 g of TiO<sub>2</sub> to get a better proportion of degradation compared to other light variations. Then the percentage of degradation was 28.65% at pH 3 and 38.97% at pH 10. The last variation that was done was the variation of methyl orange concentration of 10 ppm and 15 ppm using UVA light and 0.5 g of TiO<sub>2</sub> and in pH 7. This is because at pH 7 the largest proportion of degradation is obtained. The percentage of degradation was 32.36% at 10 ppm methyl orange and 24.92% at 15 ppm methyl orange.

## ACKNOWLEDGEMENT

We gratefully thank to the Faculty of Engineering for financial support.

## REFERENCES

- Aziztyana, Aprilya Putri. (2019). Optimization of Methyl Orange Photodegradation Using TiO<sub>2</sub>-Zeolite Photocatalyst and H<sub>2</sub>O<sub>2</sub> in Acid Condition. *Material Science and Engineering*, 546.
- Bilal, Muhammad. (2019). Effects of Solvent on the Structure and Properties of Titanium Dioxide Nanoparticles and Their Antibacterial Activity. *Research Article*, 38(4).
- Castro-Beltran, Andreas. (2017). Titanium Butoxide Molar Ratio Effect in The Tio 2 Nanoparticles Size and Methylene Blue Degradation, *International Journal for Light and Electron Optics*, 157, 890 – 894.
- Fonseca-Cervantes. (2020). Effects in Band Gap for Photocatalysis in TiO<sub>2</sub> Support by Adding Gold and Ruthenium. *Processes Journal*, 8, 1032.
- Lei, Chin Wei. (2015). Rapid Formation of 1D Titanate Nanotubes Using Alkaline Hydrothermal Treatment and Its Photocatalytic Performance, *Journal of Nanomaterial*, 2, 1 – 7.
- Sakar. (2021). Emerging Hybrid Nanocomposite Photocatalysts for the Degradation of Antibiotics:

Insights into Their Designs and Mechanisms, *MDPI Journal Nanomaterial*, 11(3).

Sreekantan, Srimala and Ibrahim, Siti Aida. (2010). Effect of pH On TiO<sub>2</sub> Nanoparticles Via Sol Gel Method, *Advanced Material Research*. 173, 184–189.

Budiarsa, Wayan. 2015. *Pencemaran Air dan Pengolahan Air Limbah*. Bali: Udayana University Press.

Christina, Maria., Mu'Nisatun., Saptaja, Rany., Marjanto, Djoko., 2007, Studi Pendahuluan Mengenai Degradasi Zat Warna Azo (Metil Orange) Dalam Pelarut Air Menggunakan Mesin Berkas Elektron, *Jurnal Forum Nuklir*, 1(1).

Endar, Bagus. 2020, *Spektrum Sinar Matahari mengandung Desinfektan Alami*, Bandung: Institut Teknologi Bandung.

Fatimah, Is. (2013). Preparasi Fe<sub>3+</sub>/TiO<sub>2</sub> - Montmorillonit Sebagai Katalis Pada Degradasi Zat Warna Azo, *Jurnal Reaktor*, 14(4).

Fendri, Sandra. (2018) Fotolisis Senyawa Paracetamol Yang Berpotensi Dalam Penanganan Limbah Obat, *Jurnal Katalisator*, 3 (2).

Ferry, Vincentius., 2017, *Ozonasi Fotokatalik Untuk Pengolahan Air dan Air Limbah*, Bandung: Institut Teknologi Bandung.

Irianto, Ketut. 2015. *Buku Bahan Ajar Pencemaran Lingkungan*. Bali: Universitas Marwadewa,

Kasuma, Sherly. 2016. *Sintesis Anorganik*. Padang: Universitas Negeri Padang Press.

Mariya. (2012). Sintesis Multiferoik BiFeO<sub>3</sub> Berbasis Pasir Besi dengan Metode Sol Gel. *Jurnal Sains dan Seni*, 1(1).

Nono. (2017) Pengaruh Jumlah Triton X100, Suhu dan Waktu Tahan Kalsinasi Terhadap Sintesis Powderzirkonia dan Aplikasinya dalam Mendegradasi Metil Orange. *Jurnal Teknik Kimia*, 23 (2).

Naimah. Siti. (2015). Keramik Sebagai Media Fotokatalis TiO<sub>2</sub> – Karbon Aktif Serta Aplikasinya Pada Kesehatan Lingkungan, *Jurnal Kimia Kemasan*, 37(2), 123 – 132.

Perdoski Satgas Covid-19. 2020. *Pengaruh Sinar Ultraviolet Terhadap Kesehatan Kajian Terhadap Berjemur (Sun Exposures)*, Perhimpunan Dokter Spesialis Kulit dan Kelamin Indonesia, Jakarta.

Putri, Lusia Eka. (2017) Penentuan Konsentrasi Senyawa Berwarna KMnO<sub>4</sub> Dengan Metoda Spektroskopi UV Visible, *Natural Science Journal*, 3(1).

Rizkiani, Ermin. (2018). Fotokatalis Bentonit-Fe<sub>2</sub>O<sub>3</sub> Untuk Degradasi Zat Warna Remazol Brilliant Blue, *Jurnal Cakra Kimia*, 7(1).

Roeslianty, Shafira. 2020. *Sintesis Karbon Kuantum Dot (Cqds) Berbahan Dasar Limbah Kulit Lemon Dan Komposit Cqds/TiO<sub>2</sub> Untuk Degradasi Metil Jingga*, Tugas Akhir Fakultas Teknologi Industri, Jakarta: Universitas Pertamina.



International Conference  
for Tropical Studies and Its Applications

Islamic Development Bank 4in1 Project  
Project Implementation Unit  
University of Mulawarman



IsDB  
البنك الإسلامي للتنمية  
Islamic Development Bank



Setyani dan Wibowo. (2017). Fabrikasi Nanotubes Titanium Dioksida ( $\text{TiO}_2$ ) Menggunakan Metode Hidrotermal, *Jurnal Kimia Valensi*. 3(1).

Suharti, Tati. 2017. *Dasar-Dasar Spektrofotometri UV-Vis dan Spektrometri Massa Untuk Penentuan Struktur Senyawa Organik*. Bandar Lampung: Penerbit Aura.

Sulistiyanto., 2015, Pengolahan Limbah Organik dan Anorganik Menggunakan Kombinasi Fotokatalis  $\text{TiO}_2$  dan Senyawa Ethylenediaminetetraacetic Acid (EDTA), *Jurnal Metana*, 11(2), 1 - 6.

Supriyanto, E., Holikin, A., & Suwardiyanto, S. (2014). Pengaruh Thermal Annealing terhadap Struktur Kristal dan Morfologi Bubuk Titanium Dioksida ( $\text{TiO}_2$ ). *Jurnal ILMU DASAR*, 15(1).

Yuningrat. (2016). Fotodegradasi Methyl Orange Dalam Reaktor Fixed Bed Batu Apung-Semen. *Jurnal Sains dan Teknologi*, 5(1).

## TEE-450

### Diagnose Digestive Disease and the Selection of Borneo Medicinal Plants as an Alternative Treatment

**Joan Angelina Widiangs\*, Annisa Chitra Adinda, Anindita Septiarini**

Department of Informatic, Faculty of Engineering, Mulawarman University, Indonesia

*Corresponding Author\*: angelinajo@fkti.unmul.ac.id*

#### Abstract

The human digestive system is the system used in the human body for the process of digestion. The human digestive system consists primarily of the digestive tract or the series of structures and organs through which food and liquids pass during their processing into forms absorbable into the bloodstream. This research develops a system of diagnosis of digestive diseases. The system assists people in knowing about the type of digestive diseases experienced, the diseases: diarrhea, constipation, ulcers, and appendicitis with fifteen symptoms and twenty-five species of medicinal plants from the Borneo rainforest. We use the Certainty Factor Method because it may facilitate the selection of symptoms of digestive disease. The diagnosis system developed to analyzes the symptoms of the disease whose inputted and then processed using the calculation of the Certainty Factor. This study aims to describe the types of digestive disease and display the species of Borneo medicinal plants. Diagnosis results using the Certainty Factor obtained a value of 87.33% for ulcer disease and medicinal plants used as alternative treatments: cinnamon, hiring, and guava leaves.

**Keyword:** Expert System, Certainty Factor, Medicinal Plant, Digestive Disease

#### Introduction

Health is one of the most important aspects of being able to do several activities. Maintaining a healthy lifestyle can help the body avoid various diseases. Therefore, the body can work optimally. Someone who does not maintain a healthy lifestyle, such as irregular dietary habits, lazy to work, and lazy, will make a person have undisciplined life and could interfere with the body health. The digestive system plays a crucial role in a person's daily activities. Better the dietary habits, the better digestive system in generating energy.

Digestive system diseases can occur by the disturbance of one or more digestive system organs. When the body cannot process foods properly, this condition can interfere the humans' daily activities. Therefore, we need a system that can help provide data regarding the actions to be taken when experiencing a disease in the digestive system. The illness of the digestive system is treatable by utilizing the properties contained in medicinal plants. The medicinal plant is a plant that benefits from curing a confident disease. Medicinal plants have a very beneficial effect as alternatives to traditional medicine. Some ailments are treatable using medicinal plants at affordable prices (Budiman et al., 2019; Ma'rifati & Kesuma, 2018; Putri, 2020).



Therefore, this study focused on an expert system applied by people who want information regarding digestive system diseases, established using the Certainty Factor method.

## Methodology

### Expert System

An expert system is a system that can solve a problem that an expert can only solve. (Giarantano & Riley, 2002; Widians et al., 2019). Bruce Buchanan and Edwan Shortliffe from Stanford University created an Expert System to perform the diagnostic process. This system is named MYCIN. The expert system has two environments, namely the development environment and the consultation environment. (Widians et al., 2018, 2019; Widians, Puspitasari, & Kurniawan, 2020; Widians, Puspitasari, Budiman, et al., 2020). The components in both parts of the expert system are in Figure 1.

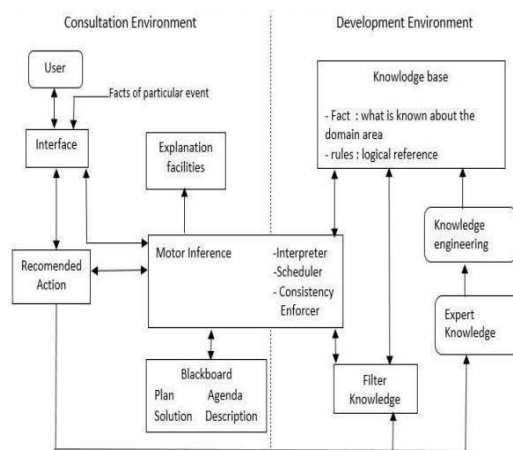

**Figure 1.** Structure Expert System

Figure 1 illustrates the components of the expert system architecture are the *UserInterface*, knowledge base, knowledge acquisition, inference engine, workplace, explanation facilities, knowledge improvement (Hatta et al., 2017).

1. **User Interface**  
The user interface is a mechanism used by the user and the system to communicate.
2. **Knowledge Base**  
Base contains knowledge for understanding, formulation, and problem solving.
3. **Knowledge Acquisition**  
Acquisition is the accumulation, transfer, and transformation of problem solving skills from knowledge sources into computer programs.
4. **Inference Engine**  
Engine contains decision-making mechanisms such as expert thinking to solve a problem.
5. **Workplace**  
Workplace is an area of a collection of working memory that serves to record the results and conclusions reached.

6. Explanation Facilities  
Facility is an additional component that will increase the capability of the expert system.
7. Knowledge Improvement  
Expert have the ability to analyse and improve performance as well as the ability to learn from their performance.

### Digestive System Disease

The human digestive system is a system that helps produce nutrients from food to become energy in the body. The organs in the digestive tract consist of the mouth, stomach, esophagus, large intestine, small intestine, and anus. If one digestive organ is disturbed, it will affect the nutrition in the human body (Shanty, 2011). In this study, there are 4 (four) diseases can be diagnose in the expert system, namely diarrhea, constipation, ulcers, and Appendicitis.

### Medicinal Plants

Medicinal plants are plants that may use as medicine in Indonesia country. Demand PERMENKES RI No. 246/MENKES/PER/V/1990 is traditional medicine as ingredients or in the form of a plant, animal, mineral, galenic preparations, or a mixture of these materials, which have traditionally for treatment. Kalimantan is one of Indonesia's islands with various biodiversity, including medicinal plants commonly used by the Borneo people to cure various diseases. A biodiversity information system for databases of medicinal plants in Kalimantan. (Angelina Widians et al., 2018; Budiman et al., 2018).

### Certainty Factor

The certainty factor presents a belief in an event based on an expert's thinking, evidence, and judgment (Widians et al., 2019; Widians, Puspitasari, Budiman, et al., 2020). Certainty factor is defined as follows:

$$CF(H, E) = MB(H, E) - MD(H, E) \quad (1)$$

CF(H,E) : the certainty factor in the hypothesis H due to evidence E  
MB(H,E) : the measure of increased belief in H due to E

MD(H,E) : measure of increase disbelief in H due to E  
H : Hypothesis

E : Evidence

Suppose another rule also concludes the same hypothesis, but with a different certainty factor (Giarantano & Riley, 2002). The certainty factors of rules concluding the same hypothesis are calculated from the function for certainty factors defined as

$$\begin{aligned} CF_{combine}(CF1, CF2) &= CF1 + CF2(1 - CF1) && \text{both} > 0 \\ CF_{combine}(CF1, CF2) &= CF1 + CF2/(1 - \min(|CF1|, |CF2|)) && \text{one} < 0 \\ CF_{combine}(CF1, CF2) &= CF1 + CF2(1 + CF1) && \text{both} < 0 \end{aligned} \quad (2)$$

The formula CFcombine used depends on whether the individual certainty factors are positive or negative. The combining function for more two certainty factors is applied incrementally. CFcombine for two CF values and the CFcombine is combination using formula (2) with the third CF value, and so forth. (Giarantano & Riley, 2002). Table 1 describes the certainty value obtained from the interpretation (term).

**Table 1.** Certainty Term

No	Certainty Terms	CF
1	Definitely not	-1.0
2	Almost certainly not	-0.8
3	Probably not	-0.6
4	Maybe not	-0.4
5	Unknown	-0.2 to 0.2
6	Maybe	0.4
7	Probably	0.6
8	Almost certainly	0.8
9	Definitely	1.0

## Results and Discussion

In this research, an expert system could diagnose human digestive diseases and provide solutions in medicinal plants as an alternative treatment. The research data was obtained from experts or experts in the health sector using the Certainty Factor method. In this study, two experts were Dr. Endang Sulastri on digestive diseases and Noorcahyati on medicinal plants.

The digestive disease diagnosis expert system uses the forward chaining inference method and the Certainty Factor. There is no provision in giving certainty values to symptoms of digestive system diseases in the medicinal field. Users can consult by selecting the symptoms they are experiencing, then the system will check the data the user selected to see whether the data is under the rules in the database. The system's flow in diagnosing digestive diseases using the Certainty Factor method in Figure 2.



the 5<sup>th</sup> ICTROPS

International Conference  
for Tropical Studies and Its Applications

Islamic Development Bank 4in1 Project  
Project Implementation Unit  
University of Mulawarman



IsDB  
البنك الإسلامي للتنمية  
Islamic Development Bank

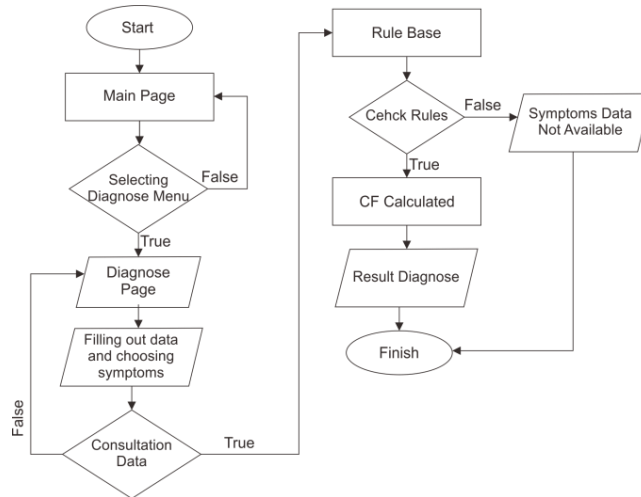

**Figure 2.** Flowchart Certainty Factor

Figure 2 illustrates expert system with Certainty Factor method.

- User accesses the expert system, the system will display the main page and several menus.
- Users can select the diagnostic menu to conduct a consultation.
- User can fill in inpatient data and choose the available symptoms.
- Subsequently, input from the user will be processed according to the existing rule base.
- Calculation of the CF value when user input is in accordance with the existing rule base.

Figure 3 describes the main page. The main page has several menus located on the left side of the page.



**Figure 3.** Main Page



the 5<sup>th</sup> ICTROPS

International Conference  
for Tropical Studies and Its Applications



Figure 4. Consultation Page

Figure 4 describes the consultation page where the user selected the evidence, the disease suffered, and information about medicinal plants as an alternative treatment. For instance, the user selects five symptoms are:

- Liquid stool accompanied by blood = 0,4
- Feeling nauseous and wanting to vomit = 0,6
- Stomach feels bloated = 0,4
- Pain in the pit of the stomach = 0,8
- The body feels warm or hot = 0,4

Based on these facts, the Certainty factor calculation. The steps for applying the CF method in identifying are as follows rule 3: *IF G08 AND G09 AND G10 AND G11 THEN Ulcer.*

The calculation CF value using equation 1 and CF combination value using equation 2.

$$CF_{c1}(CF_1, CF_2) = 0.6 + 0,12 * (1 - 0.6) = 0.648$$

$$CF_{c2}(CF_{c1}, CF_3) = 0.648 + 0.64 * (1 - 0.648) = 0,8733 \quad CF_{c3}(CF_{c2}, CF_3) = 0,8733 + 0 * (1 - 0,8733) = 0,8733$$

$$\text{Percentage} = 0,8733 * 100\% = 87,33\%$$

Table 2 describes the results of the calculation of digestive diseases using the CF method.

Table 2. Results Digestive Diseases Diagnose

No	Disease	Value CF
1	Diarrhea	8%
2	Constipation	0%
3	Ulcers	87,33%
4	Appendicitis	16%

Based on the calculation results above, the disease that has the highest CF value is ulcer disease. Accordingly, the diagnosis results of users experiencing ulcer disease are 87.33%, and medicinal plants used as alternative treatments are cinnamon, hiring and guava leaves. Table 3 states that some plants as an alternative treatment for ulcer disease.

Table 3. Medicinal Plants

No	Medicinal Plant	Disease Name	How to process	Parts used
1	Cinnamon ( <i>Cinnamomum verum</i> )	ulcer	Boiled	leather



2	Hiring ( <i>Scleria laevis Willd</i> )		Boiled	leaves
3	Guava leaves ( <i>Psidium guajava</i> )		Boiled	leaves

Figure 5 describes the results of the diagnosis of digestive diseases, namely ulcers. Patients were declared to have ulcers with a certainty value of 87.33%. Moreover, plants as an alternative treatment.

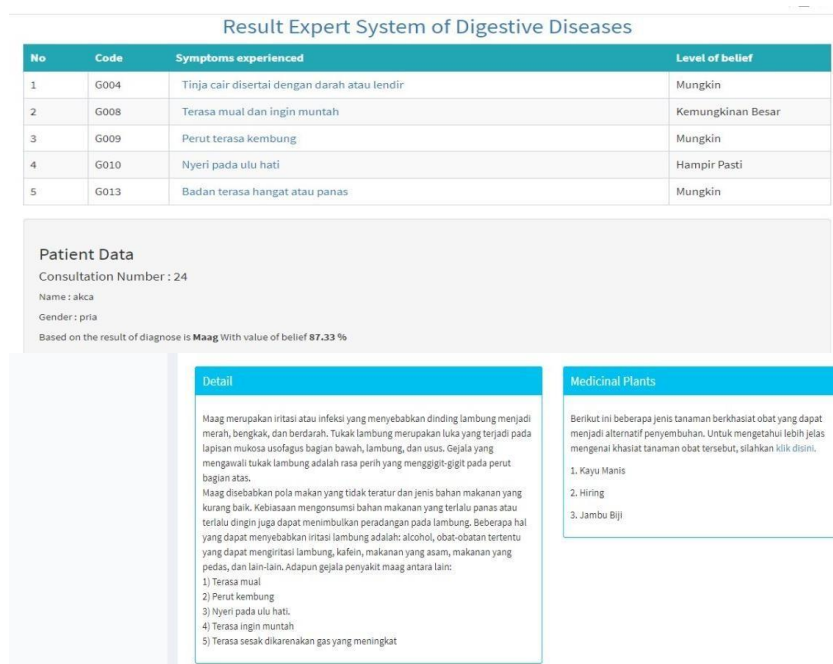

**Figure 5.** Result Page

## Conclusions

This research produced an expert system for human digestive diseases. The results obtained in the form of a diagnosis of digestive diseases are ulcers. Patients were declared to have ulcers with a certainty value of 87.33% and the types of medicinal plants used are Kayu Manis (*Cinnamomum burmannii*), Hiring (*Scleria laevis Willd*), and Daun Jambu Biji (*Psidium guajava*).

## ACKNOWLEDGEMENT

The authors thank the Experts and Balai Penelitian dan Pengembangan Teknologi Konservasi Sumber Daya Alam (BKSDA) for suggestions and the data.



the 5<sup>th</sup> ICTROPS

International Conference  
for Tropical Studies and Its Applications

Islamic Development Bank 4in1 Project  
Project Implementation Unit  
University of Mulawarman



IsDB  
البنك الإسلامي للتنمية  
Islamic Development Bank



## REFERENCES

- Angelina Widiyans, J., Wati, M., Tejawati, A., & Budiman, E. (2018). Biodiversity Information System for Management of Medicinal Plants Data Tropical Rainforest Borneo. *International Journal of Engineering & Technology*, 7(4.44), 31. <https://doi.org/10.14419/ijet.v7i4.44.26858>
- Budiman, E., Hairah, U., Haeruddin, Tejawati, A., Darmawan, S., & Wahyuni, S. (2018). Biodiversity Information System of Medicinal Plants from Tropical Rainforest Borneo Based on Traditional Knowledge Ethnic of Dayak. *Advanced Science Letters*, 24(11), 8668–8673. <https://doi.org/10.1166/asl.2018.12321>
- Budiman, E., Puspitasari, N., Wati, M., Widiyans, J. A., & Haviluddin. (2019). Web Performance Optimization Techniques for Biodiversity Resource Portal. *Journal of Physics: Conference Series*, 1230(1). <https://doi.org/10.1088/1742-6596/1230/1/012011>
- Giarrantano, & Riley. (2002). *Expert Systems Principles and Programming Third Edition* Joseph Giarrantano & Gary Riley.pdf.
- Hatta, H. R., Ulfah, F., Khairina, D. M., Hamdani, H., & Maharani, S. (2017). Web-Expert System for the Detection of Early Symptoms of the Disorder of Pregnancy Using A Forward Chaining and Bayesian Method. *Journal of Theoretical and Applied Information Technology*, volume 95. <http://repository.unmul.ac.id/handle/123456789/4666>
- Ma'rifati, I. S., & Kesuma, C. (2018). Pengembangan Sistem Pakar Mendeteksi Penyakit Pencernaan. *Jurnal Evolusi*, 6(1), 41–48.
- Putri, R. E. (2020). Sistem pakar untuk mendeteksi gangguan pencernaan dengan metode backward chaining. *Teknovasi, Jurnal Studi, Program Komputer, Sistem Pembangunan, Universitas Budi, Panca*, 07, 8–17.
- Shanty, M. (2011). *Penyakit Saluran Pencernaan (Cet.1)*. Yogyakarta Katahati.
- Widiyans, J. A., Puspitasari, N., & Ameilia, U. (2018). Expert System of Black Orchid Cultivation using Certainty Factor Method. *Proceedings - 2nd East Indonesia Conference on Computer and Information Technology: Internet of Things for Industry, EIconCIT 2018*, 35–40. <https://doi.org/10.1109/EIconCIT.2018.8878534>
- Widiyans, J. A., Puspitasari, N., Budiman, E., Wati, M., & Ramadhan, A. E. (2020). Dayak Onion (*Eleutherine palmifolia* (L) Merr) as An Alternative Treatment in Early Detection of Dental Caries using Certainty Factor. *IEEE*. <https://doi.org/10.1109/ISRIT151436.2020.9315469>
- Widiyans, J. A., Puspitasari, N., & Febriansyah, A. (2019). Disease Diagnosis System Using Certainty Factor. *ICEEIE 2019 - International Conference on Electrical, Electronics and Information Engineering: Emerging Innovative Technology for Sustainable Future*, 303– 308. <https://doi.org/10.1109/ICEEIE47180.2019.8981421>
- Widiyans, J. A., Puspitasari, N., & Kurniawan, T. B. (2020). SISTEM PAKAR BAWANG DAYAK SEBAGAI OBAT ALTERNATIF. *Jurnal Bina Komputer*, 2(2), 29–38.

## TEE-451

### Pollinator-friendly plants for supporting pollinator insect conservation on agroforestry in Jatiarjo, Prigen, East Java

Trisnawati, I. 1\*, Muryono, M. 1, Desmawati, I. 1.

Department of Biology, Ecology Laboratory, Sepuluh Nopember Institute of Technology (ITS), Indonesia

Corresponding Author\*: indahtris@yahoo.com

#### Abstract

Pollination of plants by animals is an important ecosystem service and it is estimated that about 85% of the world's flowering plants depend on animals, mostly insects, for pollination. Through increased structural and functional diversity in agricultural landscapes, agroforestry practices can also affect ecosystem services provided by insect pollinators. This study investigated pollinator assemblage diversity and species richness in agroforestry of Jatiarjo Village, Prigen, East Java, with different functional role of the associated plants (larval-host plant and food plant/nectar plant). Every three weeks sweep netting was performed for collecting flower-visiting insects whereas, yellow pan traps were deployed for collecting the insect data. A total of 676 individuals from three orders (Hymenoptera, Lepidoptera dan Diptera) were observed, including 21 families and 94 species. Butterflies were the most abundant, with 366 individuals, and the most species-rich taxa, with 54 species in five families, followed by bees having 117 individuals and 14 species in two families. Wasps were the least abundant with 53 individuals and 6 species in two families. The assemblage structure of pollinator communities as visualized through rank abundance curves, showed that there were many species with low abundance and only a few species with a much higher abundance. The most abundant species among the butterflies, in order, were *Eurema blanda*, *Junonia hedonia*, and *Zizina otis*; among bees, *Trigona laeviceps*, *Apis mellifera*, and *Apis andreniformis*. The Shannon-Wiener Diversity Index measurement showed the high diversity of pollinator insects in agroforestry areas ( $H' = 3.587$ ). We suspected that the functional roles and diversity of host plants and / food plants on agroforestry affect the high diversity level of pollinator insects. It was supported by the observation of 48 associated plant species, consisting of 54% acting as a host plant, 27% both as a host plant & food plant/nectar plant, and 9% as a food plant/nectar plant. Conservation management of pollinators by enrichment plant species as a potential host plant and food plant/nectar plant can support high species richness, the abundance of individuals, and the level of species diversity of insect pollinators.

**Keywords:** Pollinator conservation, Agroforestry, Life on land.

#### Introduction

Plant pollination by animals is a critical ecosystem service and an estimated 85% of the world's flowering plants depend on animals, mostly insects, for pollination (Ollerton et al. 2011). Insect-pollinated crops provide vital human nutrition worldwide and essential to food security (Eilers et al. 2011), and 35% of global crop production is dependent on pollination by animals (Klein et al. 2007). The most diverse group of pollinators is the Lepidoptera (and in particular the moths), with more than 140,000 species that are expected to visit





International Conference  
for Tropical Studies and Its Applications

Islamic Development Bank 4in1 Project  
Project Implementation Unit  
University of Mulawarman



IsDB  
البنك الإسلامي للتنمية  
Islamic Development Bank



flowers. This is more than twice as many as the next most diverse groups, the Coleoptera and the Hymenoptera, while Diptera is the least diverse of these four main orders of pollinating insects. In total there are approximately 350,000 known species of pollinators, servicing the approximately 352,000 species of flowering plants (Paton et al. 2008).

Insect pollination of wild plants (Ollerton et al. 2011) is also a critical life-support mechanism underpinning biodiversity and ecosystem services. The dependence on insect pollinators is even stronger in the tropics than the global average, more than 97% of all tropical lowland plants depend on insects for pollination. In a previous study, Bawa (1990) explains that up to 99% of all plants in tropical forests are dependent on animal pollination. Tropical areas host a large variety of diurnal and nocturnal pollinator groups, such as main diurnal insect pollinator groups in South America: bees and wasps, flies, beetles, butterflies (Abrahamczyk et al. 2011); in a lowland mixed dipterocarp forest Sarawak, among 41 plant species, 29 species (71%) were pollinated by bees, four (10%) by nectariniid birds, three by small dipterans, and others by moths, butterflies, syrphid flies, wasps, and beetles (Kato, 1996). Moreover, the next study of Kato et al. (2008) showed that among the 134 native plant species in Southeast Asian tropical monsoon forests, 68 were pollinated by hymenopterans and others by lepidopterans, beetles, and flies,

A decline in pollinator population abundance and diversity has been registered worldwide. It has been estimated that 40% of invertebrate pollinator species, especially bees and butterflies, may be at risk of extinction due to threats by a variety of factors. Their decline is primarily due to changes in land use, intensive agricultural practices and pesticide use, alien invasive species, diseases and pests, and climate change (FAO, 2016). According to Biesmeijer et al. (2006), anthropogenic alterations in climates and habitats have resulted in reductions in the biodiversity of many pollinator families. Different factors, abiotic and biotic, influence the biodiversity of many pollinators in the wild: predators, competitors, parasites, pathogens, and the availability of key resources (Kremen et al., 2007). Threats to pollinators may have profound consequences for ecosystem health as well as global food systems (Steffan- Dewenter and Westphal, 2008)

Managing existing habitat and restoring additional habitat for pollinators has been demonstrated to increase pollinator abundance and diversity. Agroforestry is the intentional integration of trees and/or shrubs with herbaceous crops and/or livestock in an agricultural production system (Bentrup et al., 2019). By adding structural and functional diversity to agricultural landscapes, agroforestry may be able to support pollinator conservation and pollination services (FAO, 2016). Furthermore, FAO (2016) indicates that agroforestry practices provide three overarching benefits for pollinators: (1) providing habitat including foraging resources and nesting or egg-laying sites, (2) enhancing site and landscape connectivity, and (3) mitigating pesticide exposure.

Research on pollinators and plant-pollinator interactions has expanded greatly because studies have illustrated the negative effects of habitat fragmentation on the diversity of pollinators and the significance of wild pollinators to crop pollination (Steffan- Dewenter and Westphal, 2008; Biesmeijer et al., 2006). Recent study indicates pollinator response to landscape-level land use is mixed, with the magnitude and direction of change differing among taxonomic groups. For example, some bees, butterflies, syrphid flies, and nectarivorous pollinating birds have been found to favour open, intermediate-level forested areas of semi-natural grassland or agroforestry (Tschardt et al. 2008; Millard et al., 2021).



the 5<sup>th</sup> ICTROPS

International Conference  
for Tropical Studies and Its Applications

Islamic Development Bank 4in1 Project  
Project Implementation Unit  
University of Mulawarman



IsDB  
البنك الإسلامي للتنمية  
Islamic Development Bank



Further research is required to tease out the relative contribution of plant diversity and its functional role to tropical pollinators biodiversity. Therefore, the focus of this research is on the most important groups of pollinators, such as bees, butterflies and flies, as well as the diversity and functional roles of woody plants in the study area. Wild native pollinators were considered in this study because all of them contribute to overall pollination in forested ecosystem. The current study serves as a baseline for future pollinator conservation programs related to sustainable agriculture and forest management in East Java.

## Methodology

### The Study Area

We surveyed flower/plant visitors in the field in tropical agroforestry of the Jatiarjo Village in Prigen, Pasuruan Regency, East Java at  $7^{\circ} 44' 19''$  LS  $112^{\circ} 40' 50''$  LU. The agroforestry in Jatiarjo Village is located on the slopes of Mount Arjuno-Welirang, which has a submontane forest ecosystem and an elevation of 550 m above sea level. Some areas of this study area have undergone landscape changes, from natural tropical mountain forests to agroforestry and plantations. The existence of various land-use changes can form various vegetation characters followed by differences in fauna composition. The sampling location chosen was the area under which there were ground cover plants.

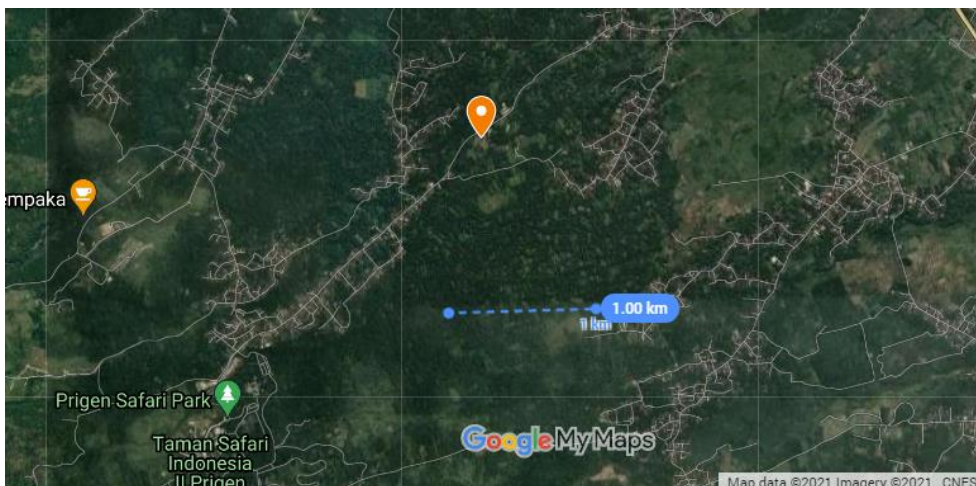

**Figure 2.** Map of sampling locations and observation in Jatiarjo Village, the Arjuno-Welirang Mountains, Prigen, East Java (Modified Google Earth, 2021). The red line indicates the boundaries of the study site.

## Sampling Method

The observations on pollinator insects were visually observed every three weeks, using the modified Pollard Walk method with the roaming method and making transects. The length of the observation transect is  $\pm 500$  meters which are divide into ten sections, and the width of the transect is 10 meters (5 meters on the left and right of the transect). Observations were carried out in the morning between 06.00 and 10.00 WIB, and in the afternoon between 14.00-16.00 WIB, on clear sunny day. Cloudy and rainy days were avoided. The data collected from observations are the species richness and abundance of pollinator insects.

Pollinators census was performed throughout the sampling period (June-September 2021) by using two standardized protocols, i.e., colored pan traps (yellow) and hand netting. Pollinator insects, especially butterflies, were sampled using the Pollard Walk method with hand netting, because butterflies have high mobility (Pollard & Yates, 1993; Subahar et al., 2007). Observations are made by identifying the morphology of pollinators through direct observation or catching using insect nets and then documented using a camera and then releasing them again. Hand netting is an active method performed for those insects attending flowers/plants. The colored pan trap, a passive method, was used to represent all insects that were actives in the morning and afternoon (diurnal) at the site, using a yellow pan (diameter 40 cm, height 20 cm) filled with soapy water. The yellow pan trap was placed at the sampling location for 24 hours..

Vegetation data at the study site was obtained by conducting a plant inventory to determine the number of species and the number of individual plants based on their functional roles, namely food plants/nectar (FP) and larval host plants (HP), or FP and HP. Pollinator insects are grouped into main groups, namely butterflies, bees, flies, moths, and so on, related to their abundance. Insects collected are pinned and labeled indicating the location, date, and host flora (in the case of hand nets). Specimens not identified at any taxonomic level are morphotyped.

## Statistical analysis

Two characteristics of the pollinator assemblage were analyzed, including abundance (total number of individual pollinators) and diversity (Magurran, 2004). Assessment of diversity was measured by species richness, diversity, evenness, and dominance. Species richness is the number of pollinator species in sampling location. Dominance (D) was calculated as the relative abundance of the most abundant flower/plant visitor species. Diversity level calculated by using the Shannon-Wiener Index and the Evenness Index. It combines the two mechanistic factors affecting diversity, i.e., dominance and species abundance, which was the complement of the Simpson Index (1-D).

In this study, species rank abundance curves were created to visualize the pollinator species through their relative abundance. It aims to show whether species in pollinator groups tend to have high or low abundant.

## Result and Discussion

A total of 676 individuals from three orders (Hymenoptera, Lepidoptera dan Diptera) were observed, including 21 families and 94 species. Results showed that the order Lepidoptera constituted 58% of the total pollinator abundance, whereas Hymenoptera and Diptera constituted 32% and 10%, respectively (Figure 2). Pollinator insects in this study are grouped into main groups, namely butterflies, bees, moths, flies, and wasps. Butterflies

showed the highest proportion of the total pollinator species and the most abundant group (58%, 54 species, 366 individuals), followed by bees (15%, 14 species, 117 individuals) and moths (12%, 11 species, 26 individuals).

Few recent studies have reported the profiles of pollinator communities in the study locations, especially in tropical forests. Irni et al. (2016) reported the research in butterfly pollinators in Gunung Leuser National Park, Aceh the pollinator species were more sensitive to the presence of the environment and very high human activities. Therefore, butterflies find at certain times when sufficient food plants and suitable host plants for breeding are there. In Sarawak, Malaysia, Momose et al. (2000) reported the pollinators of a lowland dipterocarp forest, i.e. 37 species in 22 families were visited and pollinated by several orders of insects, i.e. Coleoptera, Diptera, and Hymenoptera. In a recent study, 68 species from 134 native plant species were pollinated by hymenopterans and others by lepidopterans, beetles, flies, or diverse insects in tropical monsoon forests of the Vientiane plain in Laos (Kato et al., 2008). Sajjad et al. (2012) studied in Chat Katora forest reserve, Pakistan, and recorded 77 species in four orders, with the Hymenoptera and Diptera being the most abundant at 41% and 17%, respectively.

The diversity of different pollinator communities was evaluated using different diversity indices, i.e.. the Shannon-Weiner Index ( $H'$ ) tend to be more sensitive to rare species, the Simpson index (1-D) emphasizes more common species, whereas Evenness describes the relative distribution of individuals among the groups (Table 1).

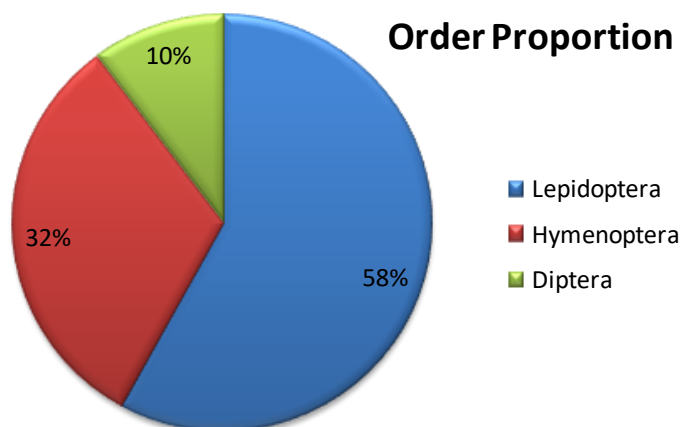

**Figure 2.** Rank order proportion of pollinator insects in agroforestry at Jatiarjo, Prigen, East Java.

**Table 1.** Diversity profile of main pollinator groups (butterflies, bees, moths, flies, and wasps in agroforestry, at Jatiarjo, Prigen, East Java

Indices	Overall	Butterflies	Bees	Moths	Flies	Wasps
Species Richness	94	54	14	11	7	6
Individual Abundance	676	366	117	26	69	53
Dominance (D)	0.019	0.033	0.101	0.142	0.227	0.192
Simpson Index (1-D)	0.981	0.967	0.899	0.858	0.773	0.808
Shannon-Wiener Index	3.872	3.645	2.417	2.161	1.723	1.711
Evenness	0.925	0.914	0.916	0.901	0.885	0.955

Both species richness and individual abundance were the highest for butterflies, and bees. The Dominance (D) value was the highest for flies and wasps. However, the Simpson Index was in reverse order, i.e. it was highest for butterflies followed by bees and moths. The value of the Shannon-Wiener Index and Evenness was greater for butterflies, followed by bees (Table 1). In this study, the values of both the Simpson and Shannon-Wiener indices of diversity were the highest for butterflies followed by bees and moths. The Simpson index is the opposite of Dominance (D) and is more sensitive to changes in common species and weighted towards more abundant species. The Shannon-Wiener index is more sensitive to changes in rare species (Magurran, 2004; Leinster and Cobbold, 2012).

When the pooled data of overall pollinator groups were subjected to visualization of their rank abundance curve, *Musca domestica* (flies), *Eurema blanda* (butterflies), and *Oecophylla smaragdina* (ants) appeared to be the most abundant species (Figure 3A). *Musca domestica* belongs to Order Diptera whose comprised the least abundance (10%) and species richness (7 species), but much higher abundance (69 individuals). Whereas, *Eurema blanda* belongs to Order Lepidoptera whose comprised the most species-rich (65 species) and individuals abundance (392 individuals). Interestingly, ants group only comprised one species, *Oecophylla smaragdina*, which comprised much higher individuals abundance (27 individuals).

Among the 21 observed families of pollinator insects, Nymphalidae, Apidae, and Pieridae comprised the highest proportions (23.5%, 16.6%, and 14.05%, respectively) among total pollinator abundance. On the contrary, Family Saturniidae and Noctuidae comprised the lowest proportion of total pollinator abundance (0.15% for each). At the species level, *Musca domestica*, *Eurema blanda*, and *Oecophylla smaragdina* had the highest proportional percentage (4.14%, 3.99%, and 3.99%, respectively). Among the butterflies, five families, i.e. Nymphalidae, Pieridae, Papilionidae, Lycaenidae, and Hesperidae, were recorded in this study. Nymphalidae was the most species-rich, and abundant family (23 species and 159 individuals) of overall pollinator insects. On the contrary, Hesperidae was the least species-rich and abundant (6 species and 19 individuals). While, among the bees, only two families were recorded (Apidae, Megachilidae). Apidae dominated among the bees group, with 12 species and 112 individuals. This study measured the species rank abundance curve among main groups of pollinators to show that there were many species with low abundance but few with much higher abundance. Among butterflies, the three most abundant species were *Eurema blanda*, *Junonia hedonia*, and *Zizina otis* (Figure 3B).

Nymphalidae is a butterfly family that has the highest species composition or richness and an abundance of



the 5<sup>th</sup> ICTROPS

International Conference  
for Tropical Studies and Its Applications

Islamic Development Bank 4in1 Project  
Project Implementation Unit  
University of Mulawarman



IsDB  
البنك الإسلامي للتنمية  
Islamic Development Bank



abundance. A study in the Biodiversity Park area of Semarang by Priyono & Abdullah (2013) showed that the Nymphalidae family was the most commonly found (33 species) because the Nymphalidae is polyphagous. Nymphalidae is polyphagous, which means they have more than one host plant and food plant. This trait causes if the primary host plant is not available, the butterfly can still use other suitable plants for food for its larvae. The study of Rahayuningsih et al. (2012) also showed that the Nymphalidae butterfly family is the family that has the highest proportion of species composition with 41 species. It was supported by the number of plants that are suitable to support the life of the Nymphalidae butterfly family as food plants and plants as shelter. Those environmental conditions have a positive influence on many types of butterfly pollinators and consequently, they will affect the species richness of butterflies (Irni et al., 2016). The active period of the Lycaenidae and Pieridae families was influenced by feed and host plants also environmental factors such as temperature, humidity, and the intensity of sunlight (Subahar & Yuliana, 2010). It is different from the Nymphalidae family that can be easily found throughout the season because they are generalists. Some of the Nymphalidae species do not depend on the presence of flower nectar alone, but these pollinators can obtain food sources from rotting fruit, carrion flesh and excrement (Sarma, et al. 2012; Sari, et al. 2013). Therefore, various species of flowers and host plants will attract different types of butterflies to nectar or lay eggs on suitable host plants (Balakrishnan & Sreekumar, 2001).

In the second dominant pollinators group, bees, only two families were recorded during the study period, i.e. Apidae and Megachilidae. The result showed that Apidae was the second most species-rich and abundant family (12 species and 112 individuals), whereas Megachilidae was the least species-rich family (2 species) and the least abundant (5 individuals). The rank abundance curve of bees also showed the same trend as that of butterflies, most species with a low abundance, but few with much higher abundance (Figure 3C). The three most abundant species among bees were *Trigona laeviceps*, *Apis mellifera*, and *Apis andreniformis*. Bees (Family Apidae) are pollinators of many flowers, have high thermoregulatory abilities, and can be active even at lower environmental temperatures. Thus, they serve as important pollinators, especially in mountainous ecosystems (Yu, et al., 2012). The study location of the agroforestry at the foothills of Mount Arjuno, which is a submontane forest ecosystem. Submontane forest ecosystem found at an altitude of 650 m – 1,500 m above sea level (Turner, et al., 2006). Although in some literature, it is also categorizing as a lowland forest zone, with an altitude of 0-1200 m asl (Yamada, 1998; Ghazoul & Sheil, 2010).

Moths comprised to five families, i.e. Erebididae, Geometrididae, Crambidae, Noctuididae, and Saturniidae. The highest number of species rich among the moths was recorded in the family Erebididae (4 species and 15 individuals). However, the minimum number of species rich and abundance were recorded in the family Noctuididae and Saturniidae (both 1 species and 1 individual). The rank abundance curve only shows *Nyctemera coleta* is the most abundant species among moths (Figure 3D). Like other pollinators, moths coevolved with plants and now both moths and plants exhibit characteristics that are adapted to each other. The flowers of some plants open in the evening and become more fragrant at night, luring in moths, which depend on scent to find food (and mates). Many moth species visit a variety of different plant species for nectar, most of which have no connection to the plants their caterpillars eat or their larval-host plants (Haase, 2020).



the 5<sup>th</sup> ICTROPS

International Conference  
for Tropical Studies and Its Applications

Islamic Development Bank 4in1 Project  
Project Implementation Unit  
University of Mulawarman



IsDB  
البنك الإسلامي للتنمية  
Islamic Development Bank

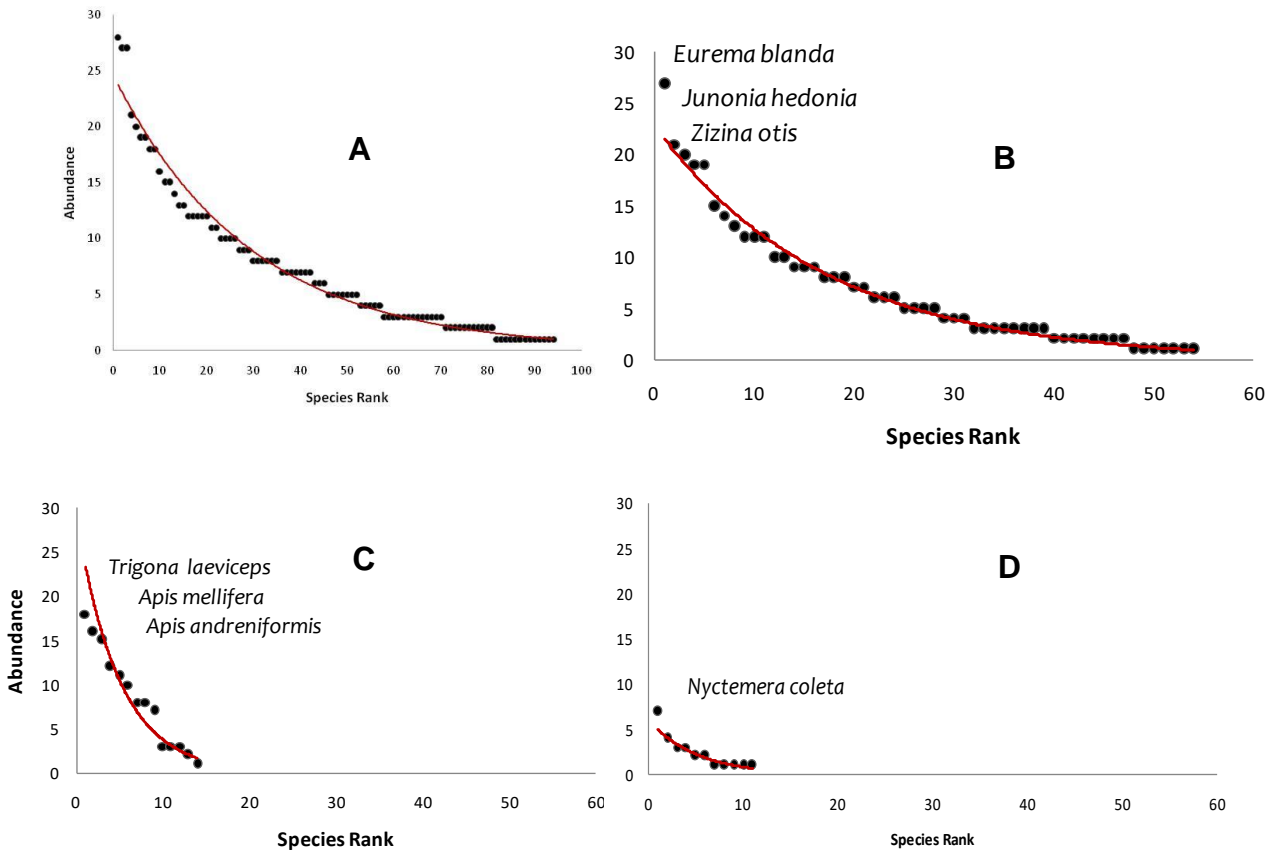
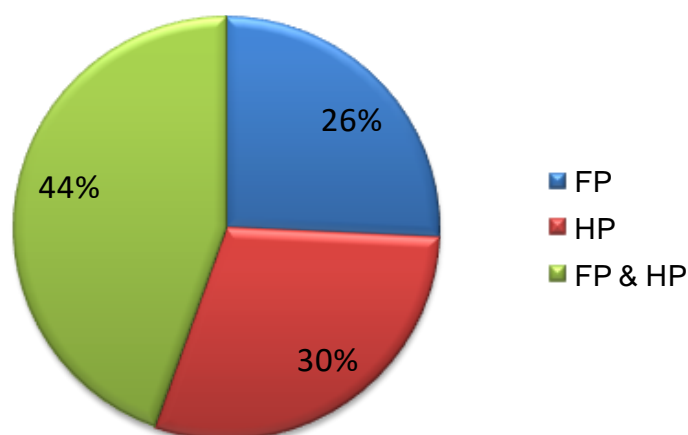

**Figure 3.** Rank abundance curves of : A) overall pollinators, B) butterflies, C) bees, D) moths. The most abundant pollinators are named.

Frank (2012) suggested that flower density and flower diversity are the most important factors and determine the diversity of pollinating insects in flowering plants and result in the stability of the population density of pollinating insects. Flowering plants will produce and increase the diversity of pollinating insects. In the process, pollinator insects need two main components, i.e., a place to nest and the availability of food sources for these insects. Therefore, the diversity of pollinator insects is determined by the availability of food sources in a plant, namely nectar and plant pollen (Amirullah et al., 2018). The results of observations of pollinator insects - plants in the agroforestry area of Jatiarjo Village (Figure 4) showed that most of these plants act as both food plants and larval host plants, which is 44%. In addition, at the Jatiarjo agroforestry, many plants also functioned as larval host plants (30%), followed by food plants (26%). Among the plants that act as both the food plants and larval-host plants, the most abundant species are *Pseuderanthemum reticulatum* and *Ruellia simplex* (Family Acanthaceae). Meanwhile, among the larval-host plants, the most abundant species are *Phyllanthus urinaria* (Family Phyllanthaceae), and *Talinum paniculatum* (Family Verbenaceae). In this study, we also recorded the three most abundant food plant species, *Cosmos caudatus*, *Tridax procumbens* (Family

Asteraceae), and *Lantana camara* (Family Verbenaceae).

### Composition of the roles of plants



**Figure 4.** Composition of the roles of plants in agroforestry, Jatiarjo Village, Prigen, East Java. FP=food plants, Hp=larval-host plant.

The host plant for insect larvae is the key to success in pollinator insect conservation. These plants are necessary for insect larvae to grow and develop into adult insects (Huang, 2011). By planting more and more variety of host plants, it will ensure the sustainability of food for the next generation of pollinator insects. Insect pollinators in their lives need food in the form of nectar and pollen. In addition to flower nectar and pollen, pollinating insects, such as worker bees, also collect water to maintain colony survival and to regulate the humidity and temperature of the hive and dissolve honey for consumption by honeybee juveniles (Huang, 2011). Both larval-host plants and food plants can guarantee the continuity of food for larval growth and development and as a source of nectar and pollen for adult pollinators (Huang, 2011). Pollen is a major source of protein, lipids, minerals, and vitamins needed for insect pollinator nutrients (Keller, et al., 2005). Gowda (2011) in Widowati (2013) explains that bees need a lot of pollen for their body growth, especially from larvae, pupae, to young bees, that are in the growth and development of the gland system. Protein is needed to produce royal jelly food for the queen and larvae (Somerville, 2000). Flower nectar is a source of carbohydrates for pollinator insects, especially insects that require high-energy food to support their activities and fly fast (Widowati, 2013).

The more abundant associated plant families of the butterfly family Nymphalidae, Pieridae and Papilionidae include Apocynaceae, Moraceae, Gesneriaceae, Solanaceae, Rutaceae, Euphorbiaceae, Annonaceae, Lauraceae, Fabaceae, Poaceae, and Arecaceae (DeVries, 2001), as well as Acanthaceae, Amaranthaceae, Anacardiaceae, Asteraceae, Fabaceae, Verbenaceae, Aristolochiaceae (Tawakkal, 2021). *Lantana camara* from the Verbenaceae family acts as a food plant/nectar plant, and *Mimosa pudica* is the host plant of the Pieridae family, especially the butterfly species *Eurema* spp. The Papilionidae family likes oranges or the Rutaceae family, also on betel (Piperaceae), avocado (Lauraceae), srikaya, and soursop (Annonaceae). Species of *Troides* sp. prefer host plants from the family Aristolochiaceae (Soekardi, 2007). Meanwhile, the Apidae





the 5<sup>th</sup> ICTROPS

International Conference  
for Tropical Studies and Its Applications

Islamic Development Bank 4in1 Project  
Project Implementation Unit  
University of Mulawarman



IsDB  
البنك الإسلامي للتنمية  
Islamic Development Bank



bee family visits plants from the Cucurbitaceae, Fabaceae, and Verbenaceae families (Tawakkal, 2021). It is supported the results of plant observations in Jatiarjo agroforestry locations, where we found many plant species such as *Lantana camara* (Verbenaceae), *Mimosa pudica*, *Arachis hypogea*, *Parkia speciosa* (Fabaceae), and others. Some of these plant families can serve as larval-host plants or food plants, which are often found at observation sites in the agroforestry area of Jatiarjo Village. Not all pollinators gather energy from eating nectar or pollen. Some species find food in rotting fruit, feces, and even carrion. Planting a mixture of larval-host plants, food plants/nectar plants, and alternative foods such as fruits will support the diversity of pollinators in the agroecosystem habitat. Therefore, the enrichment of association plants is very important, related to alternative food sources for pollinator insects.

### Conclusions

It can be concluded that the agroforestry location in Jatiarjo Village has a high value of the overall level of pollinator insect diversity, which is high (3,872). Among pollinator insects, butterflies are the group with the highest level of diversity (3,645). There were many species with low abundance, but few with a much higher abundance. The existence of pollinator management, by enriching plant species that have the potential as host plants & food /nectar plants, is able to support high species richness, abundance of individuals, and the level of diversity of pollinator insects. Plant enrichment is very important, related to alternative food sources for pollinator insects and sustainable food for the next generation.

### ACKNOWLEDGEMENT

We thank the farmers in Agroforestry Jatiarjo Village involved in this program for their willingness to host these activities and for assisting the field activities. We also thank Afthoni N. Fuadi, Refer I. Tawakkal, and Dwi Novitasari for their help with data collection and documentation, and all those who have helped the author in completing this research. This work was supported by the Directorate of Research and Community Service (DRPM), Sepuluh Nopember Institute of Technology (ITS) Surabaya.

### REFERENCES

- Amirullah, Wirdhana, S., & Afdaliana, D. (2018). Keanekaragaman Serangga Polinator di Perkebunan Kakao (*Theobroma cacao* L.) Desa Puudongi Kecamatan Kolono Kabupaten Konawe Selatan Sulawesi Tenggara. *Biowallacea*. 5: 735-749.
- Anonim. (2021). The Biodiversity of Singapore : A Digital Reference Collection for Singapore's Biodiversity. <https://singapore.biodiversity.online/>
- Balakrishnan, M., and Sreekumar, P.G. (2001). Habitat and altitude preference of butterflies in Aralam Wildlife Sanctuary, Kerala. *Tropical Ecology* 42(2):277-281.
- Bawa, K. S. (1990). Plant – pollinator interactions in tropical rain forests. *Annual Review of Ecology and Systematics* 21 : 399 – 422 .
- Biesmeijer, J. C. et al. (2006). Parallel declines in pollinators and insect-pollinated plants in Britain and the



the 5<sup>th</sup> ICTROPS

International Conference  
for Tropical Studies and Its Applications

Islamic Development Bank 4in1 Project  
Project Implementation Unit  
University of Mulawarman



Netherlands. – Science 313: 351 – 354.

Bentrup, G., Hopwood, J., Adamson, N.L., and Vaughan, M. (2019). Temperate Agroforestry Systems and Insect Pollinators: A Review. *Forests* 10, 981; doi:10.3390/f10110981

DeVries, P. J. (2001). “Nymphalidae”. Dalam Levin, S. A. *Encyclopedia of Biodiversity*. Academic Press. Hal 559-573.

Eilers E.J., Kremen C., Greenleaf, S.S. (2011). Contribution of pollinator-mediated crops to nutrients in the human food supply. *PLoS ONE* 6:e21363. <https://doi.org/10.1371/journal.pone.0021363>.

Erniwati, Kahono, S. (2010). Keragaman serangga pengunjung bunga pada lima jenis tanaman buah di Jawa Timur. *Zoo Indonesia*. Vol 20 : 27 - 38.

FAO. (2016). *Assessment Report on Pollinators, Pollination and Food Production*. Intergovernmental Science-Policy Platform on Biodiversity and Ecosystem Services, Bonn, Germany.

Frank, A. (2012). *Kajian Komposisi Serangga Polinator Tanaman Apel (malus sylvestris Mill) di Desa Poncokusumo*. Malang: PPSB.

Ghazoul, J.; Sheil, D. (2010). *Tropical rain forest : Ecology, Diversity, and Conservation*. Oxford University Press. pp 536.

Haase, K. (2020). *The Night Shift: Moths as Nocturnal Pollinators*. The Xerces Society. <http://xerces.org/blog/the-night-shift-moths-as-nocturnal-pollinators>.

Huang, Z. (2011). Honey Bee Nutrition. <http://www.extention.org/pages/28844/honey-bee-nutrition>.

Irni J, Masy'ud B, dan Haneda NF. 2017. Keanekaragaman jenis kupu-kupu berdasarkan tipe tutupan lahan dan waktu aktifnya di kawasan penyangga Tangkahan Taman Nasional Gunung Leuser. *Media Konservasi*, 21 (3): 22.

Kato, M. (1996). Plant – pollinator interactions in the understory of a lowland mixed dipterocarp forest in Sarawak. *American Journal of Botany* 83 : 732 – 743 .

Kato, M., Kosaka, Y., Kawakita, A., Okuyama, Y., Kobayashi, C., Phimminith, T., and Thongphan, D., (2008). Plant-Pollinator Interaction in Tropical Monsoon Forests in Southeast Asia. *American Journal of Botany* 95(11): 1375–1394.

Keller, I., P. Fluri, & A. Imdorf. (2005). Pollen nutrition and colony development in honey bees: part 1. *Bee World* 86 (1) 2005.

Klein AM, Vaissière B.E., Cane J.H., et al. (2007). Importance of pollinators in changing landscapes for world crops. *Proc R Soc B Biol Sci* 274:303–313. <https://doi.org/10.1098/rspb.2006.3721>.

Kremen, C., Williams, N.M., Aizen, M.A., Gemmill-Herren, B. (2007). Pollination and other ecosystem services produced by mobile organisms: A conceptual framework for the effects of land-use change. *Ecology Letters* 10(4):299- 314.

Leinster, T., Cobbold, C.A., (2012). Measuring diversity: the importance of species similarity. *Ecology* 93 (3), 477–489.

Magurran, A.E. (2004). *Measuring Biological Diversity*. Blackwell Science Ltd. pp. 261.



the 5<sup>th</sup> ICTROPS

International Conference  
for Tropical Studies and Its Applications

Islamic Development Bank 4in1 Project  
Project Implementation Unit  
University of Mulawarman



IsDB  
البنك الإسلامي للتنمية  
Islamic Development Bank



Millard, J., Outhwaite, C.L., Kinnersley, R. et al. Global effects of land-use intensity on local pollinator biodiversity. *Nat Commun* 12, 2902 (2021). <https://doi.org/10.1038/s41467-021-23228-3>.

Momose, K., Yumoto, T., Nagamitsu, T., Kato, M., Nagamasu, H., Sakai, S., Harrison, R.D., Itioka, T., Hamid, A.A., and Inoue, T. (2000). Pollination Biology in A Lowland Dipterocarp Forest in Sarawak, Malaysia: Characteristics of the Plant-Pollinator Community in a Lowland Dipterocarp Forest. *American Journal of Botany* 85(10): 1477–1501.

Müller, A. (1996). Host-Plant Specialization in Western Palearctic Anthidine Bees (Hymenoptera: Apoidea: Megachilidae). *Ecological Monographs*. 66. 235-257. 10.2307/2963476.

Ollerton, J., Winfree, R., Tarrant, S. (2011). How many flowering plants are pollinated by animals? *Oikos* 2011, 120, 321–326.

Paton, A. J. et al. (2008). Towards target 1 of the global strategy for plant conservation: a working list of all known plant species – progress and prospects. – *Taxon* 57: 602 – 611.

Pollard, E. and Yates, T.J. (1993). *Monitoring Butterflies for Ecology and Conservation*. Chapman & Hall, London. pp. 274.

Priyono, B. dan Abdullah, M. (2013). Keanekaragaman Jenis Kupu-Kupu di Taman Kehati Unnes. *Journal of Biology & Biology Education*. Vol 5 (2) : 100-105.

Rahayuningsih, M., Oqtafiana, R. Dan Priyono, B. (2012). Keanekaragaman Jenis Kupu-kupu Superfamili Papilionidae di Dukuh Banyuwindu Desa Limbangan Kecamatan Limbangan Kabupaten Kendal. *Jurnal MIPA*. Vol 53 (1) : 11-20.

Sajjad, A., Saeed, S., Bashir, M.A., (2012). Spatial variation in pollinator communities and reproductive performance of *Prosopis juliflora*. *J. Pollinat. Ecol.* 8 (9), 59–66.

Sari EFW, Soekardi H, Nukmal N, Martinus. (2013). Diversity of Nymphalidae in Tegal Island and Puhawang Kecil Island, Lampung Bay; 19-20 November 2013; Lampung, Indonesia. Lampung (ID). hlm 376-385.

Sarma K, Kumar A, Devi A, Mazumdar K, Krishna M, Mudoi P, Das N. 2012. Diversity and habitat association of butterfly species in Foothills of Itanagar, Arunchal Pradesh, India. *Zoology*. 1: 67-77.

Soekardi, H. (2007). *Kupu-kupu di Kampus Unila*. Universitas Lampung : Bandar Lampung.

Somerville, D. (2000). Honey bee nutrition and supplementary feeding. *NSW Agriculture*. DAI/178/July 2000.

Steffan-Dewenter, I. and Westphal, C. (2008). The interplay of pollinator diversity, pollination services and landscape change. *Journal of Applied Ecology* 45(3):737 – 741.

Subahar, T. S., Anzilni, F. A., & Devi, N.C. (2007). Butterfly (Lepidoptera: Rhopalocera) distribution along an altitudinal gradient on Mount Tangkuban Parahu West Java, Indonesia. *Raffles Bull Zool*. Vol 55 (1) : 175-178.

Subahar, T.S.S, Yuliana, A.N. (2010). Butterfly diversity as a data base for the development plan of Butterfly Garden at Bosscha Observatory, Lembang, West Java. *Biodiversitas Journal of Biological Diversity* 11(1) 24-28.



Tawakkal, R.I. 2021. Studi Keanekaragaman Kupu-kupu (Sub Ordo Rhopalocera) di Taman Kehati Provinsi Jawa Timur dan kawasan Hutan Ngluyu, Nganjuk. Tugas Akhir. Departemen Biologi, Institut Teknologi Sepuluh Nopember, Surabaya.

Tscharntke, T., Sekercioglu, C.H., and Dietsch, T.. (2008). Landscape constraints on functional diversity of birds and insects in tropical agroecosystems. *Ecology* 89(4):944-51.

Turner, A., E. Sanderson and M. Sweet, P. Raines. (2006). The Biodiversity of the Lower-Montane Forest Habitats of the North Negros Forest Reserve, Negros Occidental, Philippines. London: The Negros Forests and Ecological Foundation, Inc. and Coral Cay Conservation Ltd.

Widowati, R. (2013). Pollen Substitute pengganti Serbuk Sari Alami bagi Lebah Madu. *E-Journal WIDYA Kesehatan Dan Lingkungan*, Volume 1, Nomor 1, Mei-Agustus 2013, hal 31-36.

Yamada, I. (1998). *Tropical Rain Forests of Southeast Asia : A Forest Ecologist's View*. University of Hawai'i Press. pp. 416.

Yu, W.B., Li, D; Wang, H. (2012). Highly efficient pollination by bumblebees ensures seed production in *Pedicularis lachnoglossa* (Orobanchaceae), an early-flowering Himalayan. *Journal of Systematics and Evolution* 50:218-226.

## TEE-453 Degradation of Methylene Blue using TiO<sub>2</sub>/UVC Photocatalyst and Role of Scavengers

Devita Grecia Naftalia Simorangkir, Fahrizal Adnan\*, Ika Meicahayanti and Muhammad Busyairi

Department of Environmental Engineering, Mulawarman University

Corresponding Author\*: [fahrizaladnan@ft.unmul.ac.id](mailto:fahrizaladnan@ft.unmul.ac.id).

### Abstract

Photocatalyst TiO<sub>2</sub>/UVC was aimed to degrade concentration variations of Methylene Blue (MB). This research also studied effect of scavengers using carbonate (i.e. CaCO<sub>3</sub>). The research includes of synthesis using the Sol-Gel method and photocatalyst study of 0.5, 0.75 and 1 gr of TiO<sub>2</sub> which were contacted to 500 ml of methylene blue. MB concentration variations of 5 ppm, 10 ppm, and 15 ppm were studied. The effect of scavengers were studied using 10 mg and 20 mg CaCO<sub>3</sub>. Samples were taken every 30 minutes for 5 hours followed by UV-Vis spectrophotometer analysis at  $\lambda$  665 nm. The results found that 5 ppm methylene blue degradation were 53,36%, 42,99% and 18,85% for 0.5, 0.75 and 1 gr of TiO<sub>2</sub>, respectively. While, the degradations were 27,89% and 23,29% for 10 and 15 ppm of MB, respectively. The effect of scavengers were 89,72% and 80,23% for 10 mg and 20 mg CaCO<sub>3</sub>, respectively.

**Keywords:** Photocatalyst, TiO<sub>2</sub>, UVC.

### Introduction

Industry is one of the important elements in supporting development that is useful for increasing the economic growth of the Indonesian people. The increasing of industrial activities can have a positive impact such as increasing the community's economy. Negative impacts are also not spared from industrial activities, such as the existence of textile industry waste which is not good for health and the environment if it is not treated properly before being discharged into the waters (Chandra, 2019). Textile dye is a non-biodegradable pollutant, generally made from azo compounds and their derivatives which are benzene groups. Azo compounds are used as dyes, which are called azo dyes (Nurlaili, 2017).

Dye waste is an organic compound that is difficult to decompose, resistant, and toxic. One of the dyes that are often used in the textile industry is methylene blue, because the price is affordable and easy to obtain. Methylene blue dye is the most important basic dye in the dyeing process for leather, mori, cotton fabrics, and so on. The use of methylene blue can cause effects, such as if swallowed it can cause digestive tract irritation, cyanosis if inhaled, and irritation of the skin if touched by the skin (Widihati, 2011). Therefore, finding an effective treatment method for wastewater containing dyes has become an important research goal. One alternative in terms of handling the dye liquid waste is by using the photocatalytic method. This method is a method that uses a catalyst material and ultraviolet radiation in which the energy is sought which is equal to or greater than the band gap energy of the photocatalyst. This photocatalytic method decomposes the dye contained in the waste into simpler components so that it is safer for the environment (Widihati, 2011).

Photocatalyst is generally defined as a chemical reaction process that is assisted by light and a solid catalyst. The light will form electrons and holes ( $e^-$  and  $h^+$ ). Electrons will react with oxygen on the surface of the catalyst and form superoxide radicals ( $O_2^\bullet$ ), then the holes will react with water on the surface of the catalyst and form hydroxyl radicals ( $OH^\bullet$ ). High energy hydroxyl radicals will decompose organic pollutants into other harmful substances (Dini, 2014). The photocatalyst method can be carried out using a catalyst in the form of a semiconductor, such as  $TiO_2$ ,  $ZnO$ ,  $CdS$  and  $Fe_2O_3$ . Titanium dioxide ( $TiO_2$ ) semiconductors are widely used as photocatalysts, because they are chemically and biologically inert, non-toxic, stable against corrosion, affordable and abundant in nature.

Effective treatment need to be made to minimize dye waste before being discharged into the waters because of the effects it can have on the environment. The methods that have been applied, such as chemically using a coagulant that will produce sludge, physically for example sedimentation and adsorption, and biologically which are often less effective because the dye has the property of being resistant to biological degradation (recalcitrance). This method is considered to cause new problems for the environment. One of these methods is photodegradation using a semiconductor photocatalyst and ultraviolet light (Widihati, 2011). The addition of  $CaCO_3$  has also been carried out in degrading dyes. One of the studies that has been carried out by Slamet (2010), where the role of  $CaCO_3$  or what is called PCC (Precipitate Calcium Carbonate) is more dominant as a buffer, not as an absorbent. The advantage of using PCC described in the study, is that PCC as a support for  $TiO_2$ -PCC nanocomposites has more value in terms of catalyst separation due to the precipitate formed. Therefore, this study aims to determine the effect of photocatalysis with various concentrations of  $TiO_2$  to degrade various concentrations of synthetic compounds (Methylene Blue) and scavengers. This method is also expected to be applied and developed for the advancement of the textile industry in treating liquid waste in Indonesia.

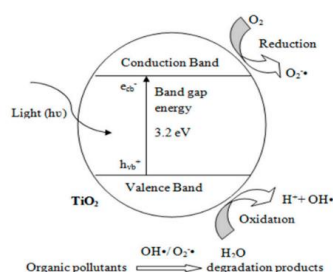

**Figure 1.  $TiO_2$  Photocatalytic Mechanism**

## Materials and Methods

This research uses the photocatalytic method, using a semiconductor catalyst in the form of  $TiO_2$  to degrade Methylene Blue (MB) organic compounds.  $TiO_2$  to be used will be obtained from the synthesis of  $TiO_2$  using the sol-gel method. In this study the pH of the solution was neutral (7). Distilled water was used in all the experiments. A set of photoreactor with dimension of 45 cm length x 40 cm width x 40 cm height and UVC lamp 254 nm equipped with the power of 8 watts were used for degradation process of MB. The absorbance value test will be carried out using a UV-Vis spectrophotometer with an optimum wavelength of MB (665 nm).

### Synthesis of TiO<sub>2</sub>

TiO<sub>2</sub> synthesis was carried out using the Sol-Gel method with a ratio of 3:1:4 between ethanol, ti-butoxide, and aquades. The sol gel process is divided into four stages, namely hydrolysis, condensation, aging, and drying. The synthesis of TiO<sub>2</sub> begins by mixing 100 ml of ethanol with 100 ml of ti-butoxide. Then 200 ml of ethanol was added, so the total of precursor solution was 400 ml. In the hydrolysis stage, 100 ml of the precursor solution is taken and will be hydrolyzed by adding 100 ml of distilled water to the burette while the solution is stirred using a magnetic stirrer and will form a sol. Furthermore, the solution will go through a condensation stage, where the molecules that have undergone condensation will combine with each other to produce gel molecules that have a large mass density and produce metal oxide crystals. Aging stage by inserting a beaker glass containing the formed solution into the refrigerator for 24 hours. Furthermore, the white solid and the liquid formed are separated, then the white solid and the formed liquid are separated, and the white solid will be transferred to a porcelain dish to be put into the oven. The drying process lasted for 4 hours in the oven at 105°C. After that, the white solid was crushed using a mortar and pestle until smooth and transferred to a crucible for calcination using a furnace with a temperature of 250°C for ± 2 hours. TiO<sub>2</sub> formed will be used in this study with various doses of TiO<sub>2</sub> as much as 0.5 grams, 1 gram, and 0.75 grams.

### Photocatalytic Activity Test

Three of the 500 mL beaker glasses are filled with each 500 mL of 5 ppm methylene blue. Then, a 0,5 grams, 0,75 grams, and 1 grams of TiO<sub>2</sub> was added to each beaker followed by UV irradiation for 5 hours inside the photo-reactor. A 5-ml sample was collected every 30 minutes for further analysis. Prior to measuring the dye concentration, the residual TiO<sub>2</sub> in the sample was separated using a centrifuge. This photo-degradation process was repeated three times. The dye concentration was determined from a standard curve using the absorbance values measured by the UV-visible spectrophotometer, which was adjusted at 665 nm (wavelength corresponding to the maximum absorption of MB). The similar procedure was carried out to examine the effects of MB concentrations, and the addition of CaCO<sub>3</sub> towards photo-degradation efficiency. The process efficiency was evaluated in terms of the percentage color removal of the dye, which was calculated using equation (1)

$$\% \text{ Color removal} = \frac{C_0 - C_t}{C_0} \times 100\% \quad (1)$$

where Co and Ct are the initial and the dye concentration at time t, respectively.

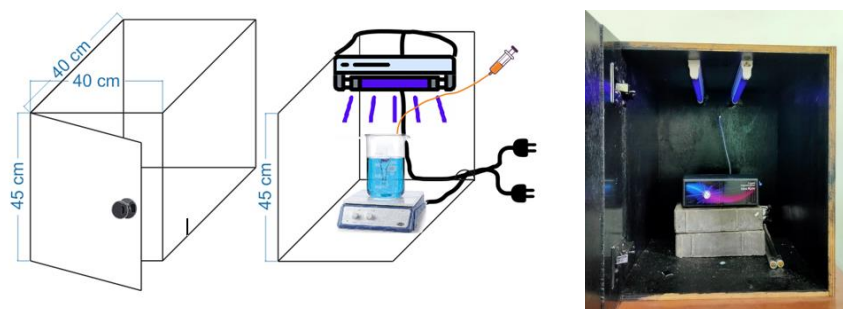

**Figure 2. Reactor design of photocatalytic test**

## Results and Discussion

### Effect of TiO<sub>2</sub> Dosage

The study of the influence of TiO<sub>2</sub> dosage on the removal of MB by photodegradation is shown in Figure 1. Based on the graph, the decrease in the color intensity of methylene blue is influenced by the dose of catalyst used, TiO<sub>2</sub>. The best percentage degradation results were shown in methylene blue solution with the addition of 0.5 gram TiO<sub>2</sub> dose with a percentage removal is 53.36%. At variation of TiO<sub>2</sub> dose of 0.75 gram and 1 gram there was a decrease in catalyst activity.

The dose of catalyst can affect the efficiency of the degradation of organic compounds. The more the number of catalysts used, the more hydroxyl radicals can be formed. However, if the amount of catalyst added too much, it will reduce the efficiency of the photocatalytic process itself. This can happen because an excess of catalyst in the solution will result in a buildup of catalyst and can increase the turbidity of the solution. The presence of excess catalyst material acts as a barrier to UV radiation. When the intensity of light entering the solution decreases due to the increasing level of turbidity of the solution, the TiO<sub>2</sub> catalyst will absorb less energy. If the energy absorbed decrease, the excitation of electrons from the valence band to the conduction band will also decrease, so that the hydroxyl radicals formed are also not optimal and can reduce the percentage of degradation produced.

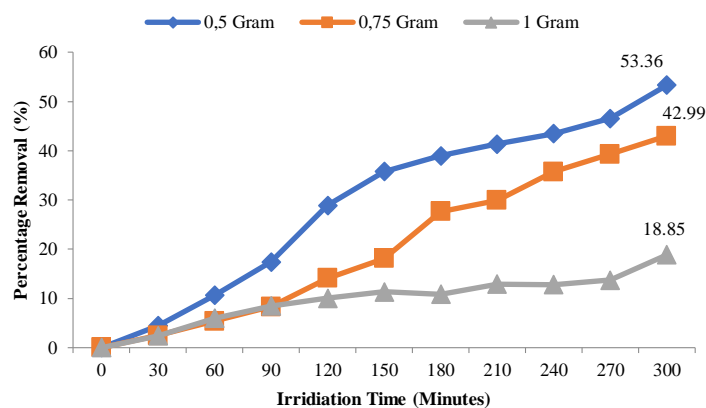

Figure 3. MB removal against TiO<sub>2</sub> concentrations.

### Effect of Methylene Blue Concentration

Based on figure 4 (a), the absorbance value decreases with increasing solution intensity. The percentage removal of degradation shown in the variation of the concentration of the 5 ppm methylene blue solution, is 53.36%. For variations in the concentration of 10 ppm methylene blue solution, the percentage of degradation seems to decrease, which is 27.89%, and for the methylene blue solution with the highest concentration, which is 15 ppm, has the lowest percentage removal, 24.11%.



A significant decrease in the percentage of color degradation was observed with an increase in the concentration of the methylene blue solution. This is associated with the coverage of the active site of the catalyst due to the increased adsorption of dye molecules resulting in the formation of hydroxyl radicals which play a role in degrading suppressed organic compounds. Another possibility is the filtering effect of UV light, which increases with increasing color intensity (high). Therefore, less photon energy will reach the active site on the catalyst, and will decrease the number of hydroxyl radicals. In addition, intermediate compounds will be formed during the degradation process by increasing the initial dye concentration and can reduce the active radical compounds that should react with the dye. As a result, the overall decolorization efficiency will be reduced. The higher the concentration of the solution will also increase the molecules contained in the solution, so that it can cause competition between methylene blue molecules to be adsorbed by the surface of the  $\text{TiO}_2$  catalyst.

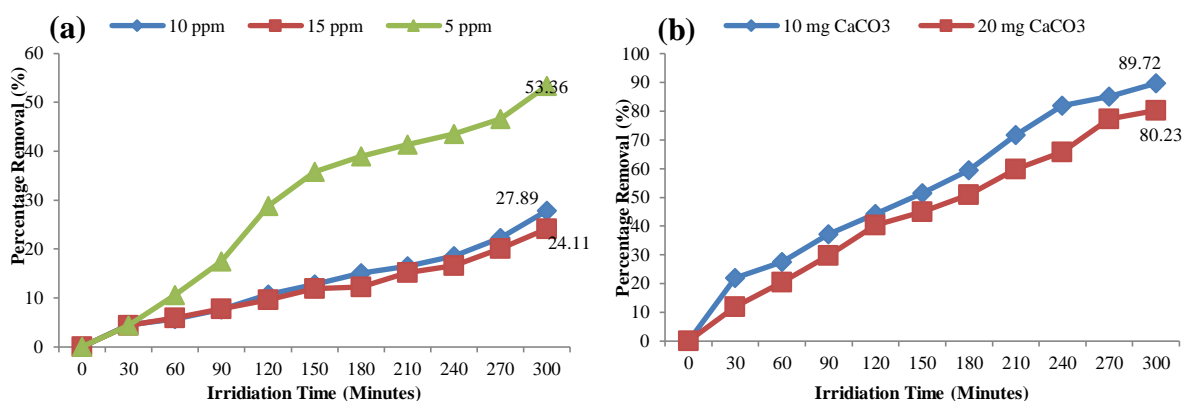

Figure 4. (a) MB removal against Concentration of MB (b) MB removal against  $\text{CaCO}_3$

### Effect of scavengers

In figure 4 (b), it shows that there is an effect of photocatalysis with the addition of  $\text{CaCO}_3$  to the methylene blue solution. With the addition of 10 mg of  $\text{CaCO}_3$ , the percentage of degradation was 89.72%. While the addition of 20 mg of  $\text{CaCO}_3$  the percentage of degradation decreased, 80.23%.

This study discusses the use of  $\text{CaCO}_3$  as a interfering substances in the photocatalysis process. According to Slamet (2010), the role of  $\text{CaCO}_3$  or PCC (Precipitate Calcium Carbonate) is more dominant as a buffer, not as an absorbent.  $\text{TiO}_2$ -PCC nanocomposite was used in a batch reactor and with UV light to degrade phenol waste. It was explained in the study, that the use of PCC alone was considered less able to reduce the concentration of color waste. However, with the addition of a small dose of  $\text{TiO}_2$ , it can significantly improve the performance of nanocomposites in the photocatalytic process.  $\text{CaCO}_3$  or PCC in photocatalysis acts as a buffer for  $\text{TiO}_2$  nanoparticles and can accelerate the rate of photocatalysis. This shows the advantages of using PCC as a buffer on  $\text{TiO}_2$ -PCC

nanocomposites which have more value in terms of separation or separation of catalysts due to the precipitate formed.

When compared with the photocatalysis process with the addition of  $\text{CaCO}_3$  and without  $\text{CaCO}_3$ , or just the methylene blue solution with  $\text{TiO}_2$ , the percentage of degradation obtained is much different. The methylene blue solution with the optimum dose of  $\text{TiO}_2$  had a degradation percentage of 53.36%, while the degradation percentage value in the methylene blue solution with the addition of an optimum dose of 10 mg  $\text{CaCO}_3$  was higher, which was 89.72%. There are factors that influence this, such as the nature of  $\text{CaCO}_3$  which has an adsorption surface so that it has the ability to degrade organic compounds, and its ability to precipitate catalysts in photocatalytic reactions and provide a better percentage of degradation with the addition of  $\text{CaCO}_3$  than without the addition of  $\text{CaCO}_3$ . When the photocatalysis process with  $\text{CaCO}_3$  is running, there is a degradation of organic compounds with the formation of free radicals to reduce the color intensity in a solution with UV light and a catalyst, and there is an active site of  $\text{CaCO}_3$  which is useful for adsorption of organic compounds and produces a high percentage of degradation of dyes.

### Conclusions

In this study, the degradation of MB organic compounds was carried out by UVC light with a neutral solution (pH=7). The results obtained in this study, that the optimum dose of  $\text{TiO}_2$  in degrading 500 ml of 5 ppm MB dye is 0.5 grams. These results indicate that an excessive dose in the photocatalytic process will inhibit the photocatalytic performance. In the various concentrations, it was found that the optimum concentration of MB solution in the photocatalysis process was 5 ppm, with a degradation percentage of 53.36%. The photocatalytic technique is favorable at low MB concentrations as the percentage removal decreased with increasing the dye concentration. The addition of  $\text{CaCO}_3$  in the photocatalysis process has a good effect. With the addition of 10 mg  $\text{CaCO}_3$ , it can degrade MB organic compounds with a high value, 86.72%, and with the addition of 20 mg  $\text{CaCO}_3$ , the percentage of degradation is 80.23%.

### ACKNOWLEDGEMENT

The author would like to thank Faculty of Engineering, University of Mulawarman, Indonesia for funding this research.

### REFERENCES

- Abdellah., 2018, Photocatalytic Decolorization of Methylene Blue using  $\text{TiO}_2$ /UV System Enhanced by Air Sparging, *Alexandria Engineering Journal*, Alexandria University
- Teng Ong., 2012, Photodegradation of Commercial Dye, Methylene Blue Using Immobilized  $\text{TiO}_2$ , *Biological and Environmental Engineering IPCBEE vol.4*, Singapore

Chandra. dkk., 2019, Degradasi Metilen Biru dengan Metode Fotokatalitik berdasarkan Variasi Berat Katalis Zeolit-WO<sub>3</sub>, *Prosiding Seminar Kimia*, [S.I.], p. 127-130.

Dini, Eka Wahyu Putri., 2014, Degradasi Metilen Biru menggunakan Fotokatalis ZnO-Zeolit, Jurusan Kimia Fakultas Matematika dan Ilmu Pengetahuan Alam Universitas Brawijaya, Malang.

Nurlalili., 2017, Pemanfaatan Limbah Cangkang Telur Ayam sebagai Adsorben Zat Warna Methyl Orange dalam Larutan, *Jurnal Inovasi Teknik Kimia*, Vol. 2, No. 2.

Widihati., 2011, Fotodegradasi Metilen Biru dengan Sinar UV dan Katalis Al<sub>2</sub>O<sub>3</sub>, *Jurusan Kimia FMIPA Universitas Udayana, Bukit Jimbaran, Bali*.

Slamet., 2010, Degradasi Fotokatalisis Limbah Fenol dengan Komposit TiO<sub>2</sub>-Precipitated Calcium Carbonate, *Departemen Teknik Kimia, FT-UI, Jakarta*

Andari., 2014, Fotokatalis TiO<sub>2</sub>-Zeolit untuk Degradasi Metilen Biru, *Jurusan Kimia, Fakultas Matematika dan Ilmu Pengetahuan Alam, Universitas Brawijaya, Malang*.

Nurzihan, Aris., 2019, Adsorpsi Zat Warna *Methylene Blue* menggunakan Bentonit Termodifikasi *Ethylene Diamine Tetra Aceticacid* (EDTA), *FMIPAKes UMRi*, Vol: 1 / Agustus 2019.

Firmansyah., 2015, Aplikasi Fotokatalis TiO<sub>2</sub>-Zeolit untuk Menurunkan Intensitas Zat Warna Tartrazin Secara Fotokatalitik, *Online Jurnal of Natural Science* Vol 4(1) :10-16, ISSN: 2338-0950



the 5<sup>th</sup> ICTROPS

International Conference  
for Tropical Studies and Its Applications



## TEE-468

### Association of Endophytic Fungi In Rice Root (*Oryza sativa L*)

Sopialena\* , Ni'matuljannah, and Devi Tantiani

Program of Plant Pest Disease Science, Faculty of Agriculture, Mulawarman University, Pasir Balengkong  
Street, Gunung Kelua, Samarinda, East Kalimantan, Indonesia.

Corresponding Author\* : sopialena88@gmail.com

#### Abstract

The aim of this research was to elaborate the association of endophytic fungi found in the root tissue of rice plants (*Oryza sativa*). The sampling location was in Sungai Kapih Village, Sambutan District, Samarinda City. This research was conducted at the Plant Disease Pest Science Laboratory, Faculty of Agriculture, Mulawarman University. The method used in this study were staining the roots of rice plants and observing endophytic fungi in the root tissue of rice plants under the microscope. The results showed that the root tissue formed hyphae and spores in the root cortex. The hyphae that were found had hyphae that were neither insulated nor insulated, forming long chains with spherical spores. In the roots of the control plants, there were no endophytic fungi that formed colonies in the root tissue.

**Keywords:** endophytic fungi, rice, association

#### INTRODUCTION

Farmers generally use pesticides excessively in controlling plant diseases without paying attention to natural enemies around the crop. The use of pesticides is carried out without taking into account the damage caused such as the occurrence of pest resistance to pesticides, pest resurgence and the death of natural enemies, damaging human health and the environment, the presence of residues in agricultural products, the emergence of new biotypes that are more resistant, and the death of biota that make up ecological habitats. not the target (Kartohardjono 2011).

Control of Plant Pest Organisms (OPT) which is commonly carried out today is control using synthetic pesticides, this happens because farmers think this control is very easy to do and produces more effective results. Control using synthetic pesticides is proven to be detrimental to humans and the agro-ecosystem environment. Environmentally friendly control is the answer to the problem of synthetic pesticides, many natural ingredients can be used as raw materials in the manufacture of biological pesticides. One of the potential raw materials for control using biological pesticides is endophytic fungi. According to (Sopialena 2020) endophytic fungi on rice plants are able to become biological agents to control pests and diseases in plants.

Endophytic fungi are fungi that live in certain tissues that are able to produce mycotoxins, enzymes and antibiotics so that their presence will be beneficial for the host plant because it increases resistance and uptake of nutrients in the soil. Compounds produced by endophytic fungi can be potential as biological controllers. Several studies on endophytic fungi that have the potential as biological control have been carried out, but not



## the 5<sup>th</sup> ICTROPS

International Conference  
for Tropical Studies and Its Applications



many studies related to observe the associations of endophytic fungi on plant roots after inoculation. This study proved that endophytic fungi can be invested through the roots of tomato plant.

## MATERIALS AND METHODS

The location of the research was carried out at the Laboratory of Plant Pests and Diseases, Faculty of Agriculture, Mulawarman University, Samarinda. The samples of tomato roots were taken from the field in Sambutan District, Samarinda City.

### Research procedure

#### Field Research

The field research used a 5 x 3 factorial study with 5 replications arranged with a Split Plot Design. The treatments in this study are:

Endophytic Fungus as Main Plot with 5 levels

C1 : *Control*

C2 : *Trichoderma* sp.

C3 : *Rhizopus* sp.

C4 : *Gliocladium* sp.

C5 : *Penicillium* sp.

Varieties as Sub-plots with 3 levels, are:

V1 : Ciherang

V2 : Kambang

V3 : Pandan Ungu

Endophytic fungus inoculation was carried out on the rice planting medium soil before transplanting. Root samples were taken from plants that had been harvested.

#### Staining of Rice Plant Roots

Root staining was carried out to see the structure and number of fungi present in the plant root tissue so as to facilitate the observation and determination of fungal infections on rice plants. Root staining in this study used the method used by (Brundrett et al. 1996) with a dye solution that had been modified with safranin and 5% methylene blue. The rice roots are cleaned with running water and put in a container. The clean rice roots are then processed sequentially by clearing and staining. Clearing was done by soaking the roots in 10% KOH solution and heated at a temperature of 60°C to 70°C for 30 minutes, then washed with distilled water until the roots were clear. After that soak using alcohol for 1 minute and wash again with distilled water. The root staining stage was carried out in 2 stages, namely soaking using safranin for 4 hours, sterilizing with alcohol for 1 minute and washing with distilled water. Furthermore, for the second staining is done by immersion using methylene blue according to the previous staining process.

#### Observation of Endophytic Fungus on Rice Root Tissue

Root samples observed were treated roots after harvest without inoculation of pathogens and after inoculation of pathogens. This was done to see the effect of endophytic fungi on the ability of biocontrol agents. The stained root samples were cut 1 cm long and placed on a glass slide. Roots were observed under a microscope



the 5<sup>th</sup> ICTROPS

International Conference  
for Tropical Studies and Its Applications



using optilab as a tool for taking documentation. The appearance of the structure of hyphae and spores is an indication that the root has been colonized by endophytic fungi found in the root cortex..

**RESULTS AND DISCUSSION**

Based on microscopic observations, endophytic fungi are present in roots by forming hyphae on the root cortex and releasing spores. The hyphae were found to have neither insulated nor insulated hyphae, forming a long chain with spherical spores. No endophytic fungi were found in the roots of the control plants that formed colonies in the root tissue. The results of the observations can be seen in table 17.

**Table 17.** Endophytic Fungi on Roots of Rice Plants var. Ciherang, Kambang and Purple Pandan in every treatment

	Varieties	reatment	Documentation
		Control	
	Ciherang	<i>Trichoderma</i> sp.	
		<i>Rhizopus</i> sp.	



the 5<sup>th</sup> ICTROPS

International Conference  
for Tropical Studies and Its Applications



		<i>Gliocladium</i> sp.		
		<i>Penicillium</i> sp.		
Kambang		Control		
		<i>Trichoderma</i> sp.		



the 5<sup>th</sup> ICTROPS

International Conference  
for Tropical Studies and Its Applications



		<i>Rhizopus</i> sp.		
		<i>Gliocladium</i> sp.		
		<i>Penicillium</i> sp.		
Pandan Ungu	Control			





the 5<sup>th</sup> ICTROPS

International Conference  
for Tropical Studies and Its Applications

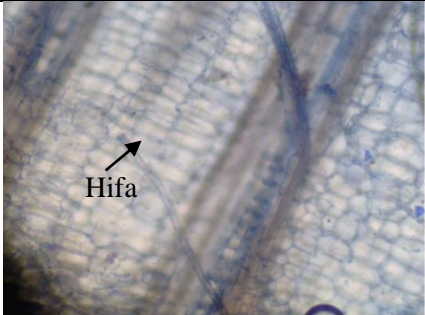
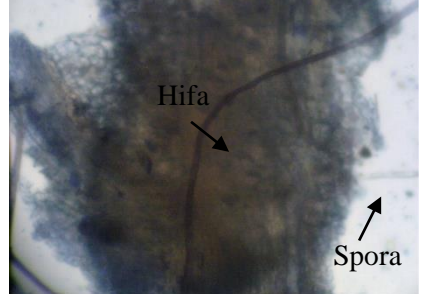

		<i>Trichoderma</i> sp.		
		<i>Rhizopus</i> sp.		
		<i>Gliocladium</i> sp.		
		<i>Penicillium</i> sp.		

In the control treatment of the Ciherang, Kambang and Pandan Ungu varieties, it could be seen that the roots were not colonized by endophytic fungi because there were no hyphae or spore structures visible. The results of root staining in all treatments proved the presence of endophytic fungus colonization in symbiosis with rice plant roots. The hyphae seen in the Ciherang variety treated by *Trichoderma* sp. showed the presence of uninsulated hyphae and seen pyramids, but in the Kambang and Pandan Ungu varieties, only uninsulated



## the 5<sup>th</sup> ICTROPS

International Conference  
for Tropical Studies and Its Applications



hyphae were seen with round spores. This refers to the results of research conducted by (Suanda 2019) which suggests that microscopic *Trichoderma* sp. have uninsulated hyphae. In a study conducted by (Sugiyarto, Umniyat, and Henuhili 2016) found that *Trichoderma* sp. in plant tissue to form hyphae that are not insulated with some forming a pyramid (Sopialena 2017). The life cycle of a pathogen starts from growing to producing reproductive organs. The entry cycle of fungi into plants includes fungal changes in the plant body and a series of changes in the host plant and the presence of pathogens (pathogenic life cycle) in it within a certain time span during the plant growth period. Important events in this cycle include: inoculation (transmission), penetration (entering the body), infection (utilization of host nutrients), invasion (expansion of attack to other tissues), spread to other sites and pathogen defense. Fungal inoculation, the inoculum can be in the form of mycelium, spores, or sclerotium. the steps that occur in the inoculation process, starting from: the inoculum of the pathogen to the surface of the host plant's body, To perform germination an appropriate temperature and humidity are needed in the form of a layer of water on the plant surface. The wet state or form of this water film must last long enough for the inoculum to enter or penetrate into cells or tissues. Penetration of these endophytic fungi directly penetrates the surface of the plant body, through natural holes, through wounds, and through intermediaries (carriers, vectors). Fungi exploit every possible pathway to gain entry to their hosts, although individual fungal species tend to have a preferred method. Fungal pathogens often use direct penetration of plant surfaces to enter the host. This requires adhesion to the plant surface, followed by application of pressure and then enzymatic degradation of the cuticle and cell wall, to overcome the physical barriers presented by the plant surface. During cuticle and wall degradation, gene switching is switched on and off in fungi, so cutinase, followed by cellulase, then pectinase and proteases are produced, attack the cuticle, cell wall, and middle lamella in sequence. That they were encountered The pressure required for the hyphae to penetrate the cell wall was achieved by first attaching the appressorium to the plant surface with a protein adhesive. The cell wall of the apressorium is then impregnated with melanin, making it impermeable to water, and able to withstand the high turgor pressure that builds up inside the appressorium. The nucleus of the appressorium in contact with the cuticle is called the penetration pore, and its walls are thinnest at this point. The increased turgor pressure causes the pores to herniate, forming penetrating pegs, which apply great pressure to the host cuticle and cell walls. An alternative route for the entry of the fungus is through an opening that is already on the surface of the plant. This could be a natural opening or a wound.

Furthermore, the fungus goes through an infection process which is a process of starting the pathogen utilizing nutrients ('food extract') from the host. This process occurs after the pathogen makes contact with susceptible cells or tissues and obtains nutrients from these cells or tissues. During the infection process, the pathogen will grow and develop in the plant tissue. Infection that occurs in the host plant, will produce symptoms of the disease that appear from the outside such as: yellowing, changing shape (malformation), or spotting (necrotic). However, infection by endophytic fungi will not cause disease symptoms in plants, because these endophytic fungi are fungi that are very able to associate well with plants, where plants can tolerate the presence of endophytic fungi and do not cause plants to get sick. After the fungus infects the plant tissue, the fungus will then invade, which is the stage of growth and development of the fungus after infection. This process is the spread of fungi from one cell to another in the host plant tissue. Then carry out the process of colonization or the formation of more than one individual fungus.

In the treatment of *Rhizopus* sp., both varieties of Ciherang, Kambang, and Pandan Ungu showed uninsulated hyphae with round spores, but no sporangiophores were seen on observation. In the observed root tissue, many



## the 5<sup>th</sup> ICTROPS

International Conference  
for Tropical Studies and Its Applications



hyphae were colonized, so it was evident that the treatment using *Rhizopus* sp. effective in increasing plant resistance. This is in accordance with the statement (Izzati, Lubis, and Hasanuddin 2019) which states that *Rhizopus* sp. is an endophytic fungus that is able to associate with plants through roots to increase plant resistance and prevent disease attacks.

Treatment of *Gliocladium* sp. on Ciherang, Kambang and Pandan Ungu varieties showed that *Gliocladium* sp. form insulated hyphae with spherical spores. The appearance of hyphae in all treatments of this fungus proved that this fungus was able to associate well with plants and was able to colonize well on plant roots. In a study conducted (Herlina 2013) suggested that *Gliocladium* sp. have hyphae that are insulated by forming a pyramid as in *Trichoderma* sp. and this fungus is also able to associate with plants by colonizing plant parts. While in the treatment of *Penicillium* sp. uninsulated hyphae structure was seen in Ciherang, Kambang and Pandan Ungu varieties. Colonization of the fungus *Penicillium* sp. can be seen very clearly in the cross section of the observed rice plant roots. The observed results are in accordance with the microscopic morphology seen in research conducted by (Assaf et al. 2020) which also shows the morphological structure of hyphae that are not insulated and have secondary metabolites that are able to prevent disease attacks. From all observations, the microscopic morphology of hyphae was in accordance with the identification observations of each of the characteristics of endophytic fungi that grew intracellularly in root cortical cells. Colonization that occurs in roots begins with the penetration of endophytic fungi into the epidermis and cortex tissue, then colonizes intracellularly and reproduces itself in these tissues and then spreads to other root tissues. In a study conducted by (Fitriani, Wiyono, and Sinaga 2020) endophytic fungi were found in the epidermal and cortical tissues that colonize intracellularly. This proves that the endophytic fungi that were applied were able to associate well with plants by colonizing the roots, whereas in plants that were not treated with endophytic fungi, hyphae structures were not visible in the root tissue. The endophytic fungus colonization and the reduced intensity of disease in plants treated with endophytic fungi showed that the symbiosis between endophytic fungi and plants was very good so that the suppression of blast disease in rice plants could be maximized.

### CONCLUSION

From the results of the study, it can be concluded that there is an association of endophytic fungi invested in the root tissue of rice plants

### REFERENCES

- Assaf, Christelle El Hajj, Chrystian Zetina-Serrano, Nadia Tahtah, André El Khoury, Ali Atoui, Isabelle P. Oswald, Olivier Puel, and Sophie Lorber. 2020. "Regulation of Secondary Metabolism in the *Penicillium* Genus." *International Journal of Molecular Sciences*.
- Brundrett, M., N. Bougher, B. Dell, T. Grove, and N Malajczuk. 1996. *Working with Mycorrhizas in Forestry and Agriculture Mycorrhizas of Australian Plants View Project Banksia Woodland Restoration Project View Project*.
- Fitriani, Mei Lita, Suryo Wiyono, and Meity Suradji Sinaga. 2020. "Potensi Kolonisasi Mikoriza Arbuskular Dan Cendawan Endofit Untuk Pengendalian Layu Fusarium Pada Bawang Merah." *Jurnal Fitopatologi Indonesia* 15 (6): 228–38.



## the 5<sup>th</sup> ICTROPS

International Conference  
for Tropical Studies and Its Applications



- Herlina, Lina. 2013. "Uji Potensi Gliocladium Sp terhadap Pertumbuhan dan Produksi Tanaman Tomat." *Journal of Biology & Biology Education* 5 (2): 88–93.
- Izzati, Inni, Lahmuddin Lubis, and Hasanuddin. 2019. "Eksplorasi Cendawan Endofit pada Akar Tanaman Karet (*Hevea brasiliensis* Muell. ARG.) sebagai Agens Hayati Jamur Akar Putih (*Rigidoporus microporus* (Swartz; FR)) di Kabupaten Asahan." *AGROEKOTEKNOLOGI* 7 (2): 347–55.
- Kartohardjono, Arifin. 2011. "Penggunaan Musuh Alami Komponen Pengendalian Hama Padi Berbasis Ekologi." *Pengembangan Inovasi Pertanian*.
- Sopialena. 2017. *Segitiga Penyakit Tanaman*. Samarinda, Kalimantan Timur.
- Sopialena, Sopian dan Lusyana Dwi Allita. 2020. "Diversitas Jamur Endofit Pada Tanaman Padi (*Oryza Sativa* L.) Dan Potensinya Sebagai Pengendali Hama Endophytic Fungi Diversity in Rice Plant and Their Potential as Pest Control" 2: 105–10.
- Suanda, I Wayan. 2019. "Karakterisasi Morfologis *Trichoderma* sp. Isolat JB dan Daya Hambatnya terhadap Jamur *Fusarium* Sp. Penyebab Penyakit Layu dan Jamur Akar Putih Pada beberapa Tanaman." *Widya Biologi* 10 (9): 1689–99.
- Sugiyarto, Lili, Siti Umniyatie, and Victoria Henuhili. 2016. "Keanekaragaman Anggrek Alam Dan Keberadaan Mikoriza Anggrek Di Dusun Turgo Pakem, Sleman Yogyakarta the Diversity of Orchid Mycorrhiza Existence in Turgo Village." *Sains Dasar*.



the 5<sup>th</sup> ICTROPS

International Conference  
for Tropical Studies and Its Applications



**TEE-484**

## **Fauna Exploration and Inventory in the Mount Kelua Fkip Campus Area, Mulawarman University**

**Muhammad Rizky Alfariz, Teguh Pribadi, Mohammad Indra Pratama, Muhammad Syafa'at  
Abdullah, Putri Nulissa, Romaeda Hasibuan, Silla Ariyani, Zenia Luthfi Kurniawati**

Faculty of Teacher Training and Education, Mulawarman University, Indonesia

*Corresponding Author\*:* nikyaulia24@gmail.com

### **Abstract**

Diversity is one of the important factors in determining the state and quality of an environment. The objectives of this research are as follows: Knowing the diversity of fauna species found in Mulawarman University, Knowing the fauna habitats in Mulawarman University and analyzing the benefits of the diversity of fauna found in the Mulawarman University environment. The research was carried out in April - June 2021, in the FKIP Campus area of Mulawarman University, Kec. North Samarinda, Samarinda City. The method used in self-observation is the method of observation and documentation with data analysis techniques in the form of descriptions. From this observation itself, data obtained in the form of family classification with a total of 13 types of families where in aquatic there are 2 families, in mammals there is 1 family and in insects there are 10 families. From the data obtained during the observation, it is known that the fauna contained in Mulawarman University itself is 17 species. This shows that the diversity of species at Mulawarman University is still little or less diverse.

**Keywords:** *Inventory, Diversity, Fauna*

### **Introduction**

Mulawarman University is one of the universities in Indonesia. Mulawarman University is located in the province of East Kalimantan, precisely in the heart of the city as well as the area which is the capital of East Kalimantan Province, namely the city of Samarinda. Mulawarman University as the largest university in East Kalimantan is the most natural to have a large campus area. Of the four campuses owned by Mulawarman University, the main campus is located in Gunung Kelua with an area of about 70 hectares containing many rectorate buildings, libraries and campus buildings from 13 existing architectures. And one of these 13 architectures is the Faculty of Teacher Training and Education, which is the main location of our observations. The biodiversity of Indonesia's flora and fauna invites attention and admiration for various parties in Indonesia and throughout the world. BAPPENAS (2003) recorded no less than 515 species of mammals (the world's largest), 1531 species of birds (fourth most), 270 species of amphibians (fifth most), 600 species of reptiles (third most), 1600 species of butterflies (most) and 20,000 species of flowering plants (seventh most) inhabit the land and water habitats of this vast Indonesian archipelago. According to Law No. 5/1990, it is stated that fauna/animals are all types of animal natural resources that live on land, and/or in the air, and/or in the air, while wild fauna are all animals that live on land, and/or in the air, and or in the air that still has the characteristics of a liar, both free living and being cared for by humans. The law states the safety and security of the diversity of flora and fauna that are rare and have certain characteristics or are found in nature reserves,



## the 5<sup>th</sup> ICTROPS

International Conference  
for Tropical Studies and Its Applications



both on land and in waters (sea). (Mellawati, 2010: 67-68).

Under normal conditions, this campus will deal directly with students passing by on campus, so that it will have the potential to disrupt the fauna habitat on campus. So, there are concerns about the loss of these fauna due to too often interacting with humans. We can see this in the extinction of the dodo bird due to interacting with sailors from Europe whom he had never met. (Rijsdijk, 2016: 4). So the need for data collection or fauna inventory to find information on fauna around the campus, to minimize the loss of several fauna species which is added because in the last 10 years there has been no fauna inventory in the FKIP campus area. So, our team of observers are interested in conducting observations with the title "Fauna Exploration and Inventory in the Mulawarman University FKIP Campus Area".

The purpose of this research itself is as follows.; Knowing the diversity of fauna species found at Mulawarman University, Knowing the fauna habitats in Mulawarman University, AND Analyzing the benefits of the diversity of fauna found in the Mulawarman University environment. Based on the research objectives. So, the benefits of this research are as follows: To find out the diversity of fauna species found at Mulawarman University, To find out the fauna habitats in Mulawarman University, To find out the analysis of the benefits of fauna diversity found in the Mulawarman University environment

### Methodology

The research was carried out in April - June 2021, to coincide in the Mulawarman University area, Kec. North Samarinda, Samarinda City, East Kalimantan. The research location itself is divided into three paths, namely Gazebo, Water Pool and Park. The research was carried out by making direct observations to the location to see the real condition and presence of fauna in the Mulawarman University Area.

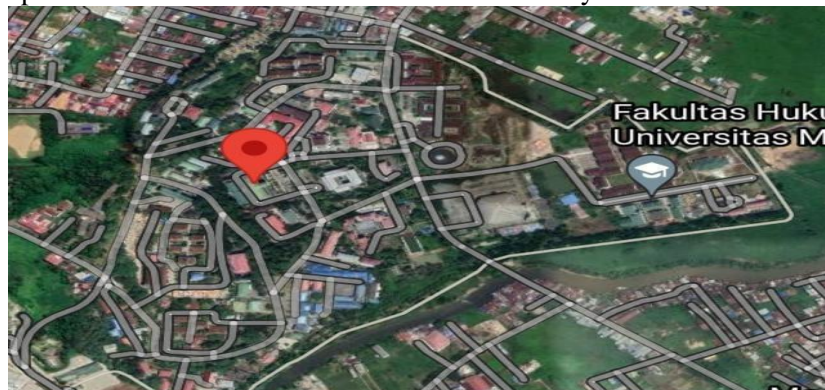

Picture 1. Map of Observation Locations on the Mulawarman University FKIP Campus

#### Data Collection Technique

The data needed in this study uses several techniques including the following:

##### Observation

This research itself was carried out in April - June 2021, coinciding in the area of Mulawarman University, Kec. North Samarinda, Samarinda City, East Kalimantan. The research was carried out by making direct



## the 5<sup>th</sup> ICTROPS

International Conference  
for Tropical Studies and Its Applications



observations to the location to see the real condition and presence of fauna in the Mulawarman University Area. Observations are made to see the natural potential that can be used as a habitat for various types of animals

### 2.1.4 Documentation

In addition to observation, data collection was also taken through other sources such as journals, theses, theses and the internet as well as other materials related to this research. The documentation method itself aims to be evidence that the preparation has carried out research through electronic and print media

### 2.2 Data Analysis Technique

The data that has been collected is analyzed by formulating words and sentences that have been obtained in the field so that they can answer problems with original evidence based on the research studied. This research is carried out by exploring the data. The data is analyzed with guaranteed references, complete with descriptions containing explanations or depictions and telling the actual state of the object under study, the data is then classified according to the focus of the research that has answered all the questions in the problem formulation, in another sense to solve and answer all the questions in the problem formulation we use a description technique. Primary data were obtained from animal observations, types of animals, and the number of individuals. Secondary data were collected through literature, interviews, and other sources regarding the general condition of the research location, climatic conditions, textbooks, theses and research journals as well as practicum reports.

#### Species Diversity Index (H')

The index used is the Shannon-Wiener Diversity Index, with the formula :

$$J' = -\sum_{i=1}^S p_i \ln p_i$$
$$p_i = n_i/N$$

Description :

H' = Shannon-Wiener species diversity index

n<sub>i</sub> = numbers of individuals of the 1st species

N = number of individuals of all species

Criteria for the Shannon-Wiener Diversity Index Value (H')

$H' \leq 1$  = low diversity

$1 < H' < 3$  = medium diversity

$H' \geq 3$  = high diversity

#### Species Evenness Index (J')

Species evenness index expressed with formula :

$$J' = H' / \ln S$$

Description :

J' = Pielou evenness index

H' = Species diversity index

S = Number of species

#### Criteria for the Species evenness index (J')

$0 < J \leq 0,5$  = stressed community

$0,5 < J \leq 0,75$  = labile community

$0,75 < J < 1$  = stable community

Margalef Species Wealth Value (Richness Index)



## the 5<sup>th</sup> ICTROPS

International Conference  
for Tropical Studies and Its Applications



Co-Organized by :

The species richness value used is the Margalef species richness index using the following formula :

$$DMg = (S - 1) / \ln N$$

Description

DMg = Margalef Species Wealth Value

S = Number of species found

N = Number of all species

The criteria for the Margalef Species Wealth Index value are as follows

$D < 2,5 = \text{low level of richness}$

$2,5 < D < 4 = \text{moderate level of richness}$

$D > 4 = \text{high level of richness}$

Results and Discussion

Habitat Condition

Data collection carried out in the field itself was carried out on 3 types of existing habitats, namely Gazebos, Ponds / Trenches and Parks. From the data obtained, it is known that there are 17 types of fauna from 13 families which can be grouped into 3 orders, namely Aquatic, Mammal and Insect. For the next discussion, we will discuss the order of Aquatic and Insects.

No	Ordo	Famili	Jenis	Lokasi			Total	Stat us
				A	B	C		
1	Aquatik	Aplocheilidae	<i>Aplocheilus panchax</i>	1	0	0	1	LC
2		Poeciliidae	<i>Poecilia reticulata</i>	2	0	0	2	LC
3	Mamalia	Felidae	<i>Felis catus</i>	0	2	0	2	-
4	Insekta	Acrididae	<i>Valanga sp.</i>	0	0	1	1	LC
5		Aeshnidae	<i>Aeshna petalura</i>	0	0	1	1	LC
6		Apidae	<i>Xylocopa appendiculata</i>	0	0	1	1	LC
7		Formicidae	<i>Oecophylla smaragdina</i>	0	0	1	1	-
8		Mantidae	<i>Mantis religiosa</i>	0	0	1	1	LC
9		Nymphalidae	<i>Acraea terpsicore</i>	0	0	1	1	-
10			<i>Elymnias hypermnestra</i>	0	0	1	1	-
11			<i>Melanitis leda</i>	0	0	1	1	-
12		Papilionidae	<i>Papilio demoleus</i>	0	0	1	1	-
13		Pieridae	<i>Colias croceus</i>	0	0	1	1	-
14			<i>Leptosia alcesta</i>	0	0	1	1	-
15		Pyrgomorphidae	<i>Atractomorpha crenulate</i>	0	0	1	1	-
16			<i>Atractomorpha similis</i>	0	0	1	1	-





## the 5<sup>th</sup> ICTROPS

International Conference  
for Tropical Studies and Its Applications



17		Reduviidae	<i>Zelus luridus</i>	0	0	1	1	-
		<b>Total Individu</b>		3	2	14	19	
		<b>Total Jenis</b>		2	1	14	17	

Location A : Pond and Trench LC : Least Concern (Low Risk)

Location B : Gazebo

Location C : Park

\*Conservation status based on IUCN Red List

Diversity is one of the important factors in determining the state and quality of an environment. The research location, which is centered at Mulawarman University, is a habitat that does not have many types of mammals, relatively few or less diverse plants, and the absence of natural water sources. This is the main cause of less diversity in the Mulawarman University Area compared to other locations. Based on data obtained from the International Union for Conservation of Nature and Natural Resources (IUCN), it is known that of the 17 species of fauna found at the observation site, it is known that 11 of them are not listed on the IUCN Red List. Meanwhile, 6 other fauna species are listed as Least Concern (LC) or fauna species with low risk. The data obtained is very important as a benchmark in monitoring the diversity of fauna species in Kalimantan, especially in East-North Kalimantan.

### INSEKTA

Based on observations made on the Park route, 14 species of insects belonging to 10 families were found. The 10 families found were Acrididae, Aeshnidae, Apidae, Formicidae, Mantidae, Nymphalidae, Papilionidae, Pieridae, Pyrgomorphidae and Reduviidae.

In this observation, the data obtained in the form of data analysis index values are as follows.

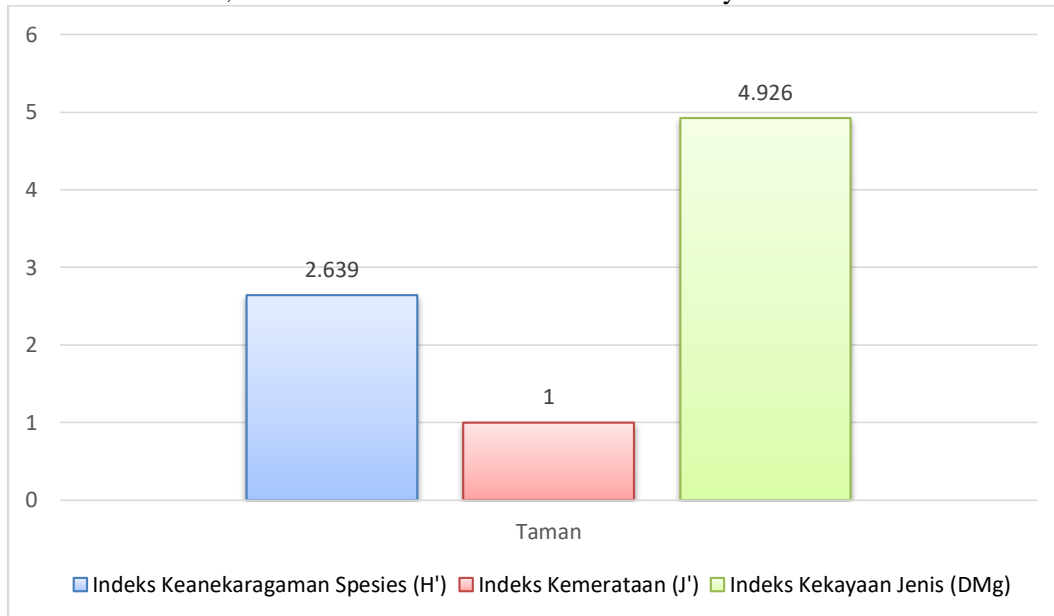

**Gambar 2.** Nilai Indeks Keanekaragaman Spesies, Kemerataan dan Kekayaan Jenis dari Spesies Insekta di Kampus FKIP Universitas Mulawarman



## the 5<sup>th</sup> ICTROPS

International Conference  
for Tropical Studies and Its Applications



From the data above, it can be seen that the value of the species diversity index for insects is 2,639. Adelina (2016: 53) herself explained that for the Shannon-Wiener diversity index criteria, moderate diversity itself occurs if the value obtained is between 1 and 3 ( $1 < H' < 3$ ). This shows that the diversity of insect species on the FKIP campus itself is of moderate diversity. The diversity in the data is due to the fact that even though the FKIP campus park is in the middle of the city, the closure of the campus for about a year due to a pandemic has caused the species that live there to be undisturbed from interactions with humans. This can lead to an increase in the number of insect species found in the FKIP Campus Park. The evenness index for insects in the park itself is 1. According to Wahyuningsih (2019: 95), the Species Evenness Index (J) with a value of  $J = 1$  indicates that the level of evenness of species in the environment is quite high or stable. This, according to Insafitri (2010: 57) shows that the species that live in the FKIP campus park have an even number and none of them dominate one another. The Species Richness Index (DMg) according to Santosa (2008: 2) serves to determine the species richness of each species in each community encountered. This shows that the greater the value of the species richness index, the more diverse the species in the environment. From the table above, it can be seen that the value of the species richness index of the insects in the FKIP campus park is 4.926. According to Wahyuningsih (2019: 95), a species richness index with a value of  $D > 4$  indicates a high level of species richness in that location. This shows that the number of species that live in the Mulawarman University FKIP Campus Area is quite large so that it can create an ecosystem that is rich in various species. From the data obtained, it can be seen that of the 14 Insect species in the FKIP Campus, 4 of them are classified as low risk (Least Concern) and are listed in the IUCN (International Union for Conservation of Nature and Natural Resources).

## AQUATICS

For Aquatics itself, based on the results of observations that have been made in Trenches and Ponds located on the FKIP Campus, it is known that there are 2 aquatic species originating from 2 families that live in the FKIP Campus Area. Two families were found, namely Aplocheilidae and Poeciliidae. In this observation, data were obtained which were then converted into data analysis index values as follows:.

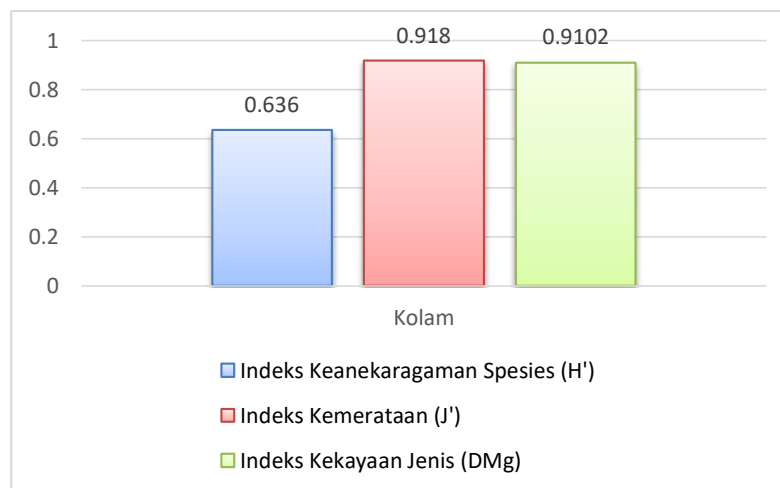

Based on the data above, it is known that the value of the Aquatic Species Diversity Index in the FKIP Campus pond is 0.636. Based on the criteria for the Shannon-Wiener Diversity Index by Adelina (2016: 53), it is known



## the 5<sup>th</sup> ICTROPS

International Conference  
for Tropical Studies and Its Applications



that if the diversity index value of a place is  $H' 1$ , it can be concluded that the diversity at that location is low. This can happen because there are only 2 species from 2 families that can be found in the FKIP Campus pond, so it can be concluded that the species diversity in this pathway is quite low. For the evenness index ( $J'$ ), it is known that the value of the aquatic evenness index is 0.918. According to Wahyuningsih (2019: 95), the Species Evenness Index ( $J$ ) with an index value of  $0.75 < J 1$  indicates that the community in the environment is quite stable. This shows that although the species present are quite low, the number of species that live is quite evenly distributed and none of them dominate each other so as to create a stable environment. For the Margalef Richness Index, it is known that the value of the species richness index in the FKIP Campus Pool is 0.9102. According to Wahyuningsih (2019: 95), the species richness index with a value of  $D < 2.5$  indicates that the level of species richness in the environment is quite low. This can happen because at the time of observation, only 2 aquatic species can be found living in the pond of the FKIP Campus. From the data above, it is also known that two Aquatic species found in the FKIP Campus Pond have a low risk or Least Concern status by IUCN (International Union for Conservation of Nature and Natural Resources). In addition, the *Poecilia reticulata* species itself has benefits as an ornamental fish, so it has a fairly profitable selling value

### Conclusions

Geologically, the distribution of fauna in Indonesia is divided into 3 regions, including the Sunda Plain, the Sahul Plain and the Transitional Area (Wallace Region). For this observation itself was carried out at Mulawarman University which is included in the Sunda Plain (Asiatic). From the data obtained during the observation, it is known that the fauna contained in Mulawarman University itself is 17 species. This shows that the diversity of species at Mulawarman University is still little or less diverse. The diversity of fauna species occurs due to several factors, so that a patterned diversity is formed in its distribution, namely the spatial aspect. Factors that affect the distribution of fauna in Indonesia, namely the influence of geological changes, the influence of climate conditions of an area, and the influence of human activities. To prevent the extinction of this fauna, efforts are made, among others by establishing a place of protection for fauna so that their breeding is not disturbed, building several rehabilitation centers and breeding places for certain animals, development with an environmental perspective, stipulating several types of animals that need to be protected, carry out forest conservation efforts, carry out animal conservation efforts, and carry out efforts to preserve aquatic biota.

### REFERENCES

- Adelina, Maya., dkk. 2016. Keanekaragaman Jenis Burung Di Hutan Rakyat Pekon Kelungu Kecamatan Kotaagung Kabupaten Tanggamus. *Jurnal Sylva Lestari*. 4 (2).
- Insafitri. 2010. Keanekaragaman, Keseragaman, Dan Dominasi Bivalvia Di Muara Sungai Porong Sebagai Area Buangan Lumpur Lapindo. *Jurnal Kelautan*. 3 (1).
- Kamal, M., Yustian, I., & Rahayu, S. 2011. Keanekaragaman Jenis Arthropoda di Gua Putri dan Gua Selabe Kawasan Karst Padang Bindu, OKU Sumatera Selatan. *Jurnal Penelitian Sains*. 14 (1).
- Lose, I Made Ismail., dkk. 2015. Keanekaragaman Jenis Fauna Darat Pada Kawasan Wisata Mangrove di Desa Labuan Kecamatan Lage Kabupaten Poso. *Warta Rimba*. 3 (2).
- Mellawati, Junne., dkk. 2010. Identifikasi Keanekaragaman Flora dan Fauna Berau Kalimantan Timur Pada Kegiatan Pra Survei Tapak PLTN. *Jurnal Pengembangan Energi Nuklir*. 12 (2).



## the 5<sup>th</sup> ICTROPS

International Conference  
for Tropical Studies and Its Applications



Rijsdijk, Kenneth F., et al. 2016. A Review of The Dodo and Its Ecosystem: Insights From a Vertebrate Concentration Lagerstätte in Mauritius. *Journal of Vertebrate Paleontology*. 35 (6).

Santosa, Yanto., dkk. 2008. Studi Keanekaragaman Mamalia Pada Beberapa Tipe Habitat Di Stasiun Penelitian Pondok Ambung Taman Nasional Tanjung Puting Kalimantan Tengah. *Media Konservasi*. 13 (3).

Sari, Rizky Novia., dkk. 2019. Biodiversitas Fauna Sebagai Salah Satu Indikator Kesehatan Mangrove. *Jurnal Perennial*. 15 (2).

Suprpto. 2014. Indeks Keanekaragaman Jenis Ikan Demersal Di Perairan Tarakan. *Bawal*. 6 (1).

Wahyuningsih, Endah., dkk. 2019. Komposisi Dan Keanekaragaman Tumbuhan Pada Habitat Ketak (*Lygodium circinatum* (Burm.(SW.) Di Pulau Lombok, Nusa Tenggara Barat. *Jurnal Hutan Tropis*. 7 (1).

Wibowo, Cahyo., Slamet, Syamsudin Ahmad. 2017. Keanekaragaman Makrofauna Tanah Pada Berbagai Tipe Tegakan Di Areal Bekas Tambang Silika Di Holcim Educational Forest, Sukabumi, Jawa Barat. *Jurnal Silvikultur Tropika*. 08 (1).



the 5<sup>th</sup> ICTROPS

International Conference  
for Tropical Studies and Its Applications



## TEE-028

# Supplier Selection Using AHP dan TOPSIS: a Case Study in The Bakery

**Farida Djumiati Sitania\***

Department of Industrial Engineering, Mulawarman University, Indonesia

*Corresponding Author\*: ida.sitania@gmail.com*

### Abstract

The main raw materials in bread production are wheat flour. X Bakery has seven suppliers who frequently supply flour. The common problems at X Bakery related to the supply of raw materials are the different prices between each supplier, inaccuracies in delivery times, and the non-standard quality of raw materials. The purpose of this research is to choose the right raw materials supplier at X Bakery. Decision making on supplier determination is done by selecting suppliers based on the criteria determined by the company using the AHP and TOPSIS methods. The AHP method is used to determine the most influential criteria and produce a weighted criterion value. The AHP output will be used as input to the TOPSIS method for supplier ranking. Of the seven criteria, quality is the priority by X bakery, while the the selected supplier to supply wheat flour is supplier A.

**Keywords:** Suppliers selection, Analytic Hierarchy Process (AHP), Technique For Order Preference by Similarity to Ideal Solution (TOPSIS).

### Introduction

The raw materials inventory with adequate quality and quantity is one of the main factors in a company line production. In its production activities, the company needs suppliers as business partners who have an important role in ensuring the availability of raw materials for the company production. Determination of suppliers as business partners is an important decision for a company, because it is related to the cost and quality of the raw materials supplied. Pujawan (2010) states that the purpose of the supplier selection process is to reduce purchase risk, build close long-term relationships and to maintain the quality of product raw materials. Selection of the right supplier can reduce the cost of raw materials and increase the company's competitiveness (Ceby and Bayraktar, 2003).

X Bakery is a micro, small and medium enterprise (UMKM) that produces various types of cakes and breads. This UMKM, which is located in Balikpapan, produces to orders and stock. The main raw materials used to produce bread are flour. X Bakery has seven suppliers who frequently supply flour. The common problems in supplying raw materials at X Bakery are the different prices between each supplier, inaccuracy in delivery times, and non-standard material quality. To increase the company's competitiveness, X Bakery must be able to determine the right supplier of raw materials. Suppliers must be able to provide raw materials at the right price, quantity, quality and time.

The purpose of this study is to determine the right supplier of wheat flour at X Bakery. Determination of suppliers is done using the Analytical Hierarchy Process (AHP) and Technique For Order Preference by Similarity to Ideal Solution (TOPSIS). The AHP method is used to determine the most influential criteria and



## the 5<sup>th</sup> ICTROPS

International Conference  
for Tropical Studies and Its Applications



produce a weighted criterion value. The output of AHP will be used as input to the TOPSIS method for ranking suppliers. It is hoped that the selected potential suppliers can supply raw materials at the right price, quality and time and can work together in the long term.

### Methodology

The research was conducted at X Bakery, Balikpapan. This study uses the AHP and TOPSIS methods to determine suppliers of wheat flour. The research stages consist of data collection, data processing and analysis and the last is drawing conclusions.

#### Data Collection

Data collection was done by deliberately selecting respondents related to the research topic or purposive sampling method. At this stage, it is assumed that respondents have competence in choosing suppliers who represent factories and have the authority to provide information about the data needed in research (Merry et al., 2014).

The data collected consisted of data from interviews and questionnaires. The selected respondents are business owners, who are considered to understand the issue of raw materials and suppliers.

The questionnaire consists of two stages, the first is a pairwise comparison questionnaire conducted to obtain the weight of the criteria and sub-criteria in the completion of the AHP with different priorities and weights. The second questionnaire is a supplier selection assessment questionnaire used to give a supplier assessment weight with predetermined criteria for the completion of the TOPSIS.

Pujawan (2010) states that there are twenty-one criteria for supplier selection and evaluation. These criteria are listed in table 1 below.

**Table 2.** Supplier Selection Criteria

No	Criteria	No	Criteria
1.	Quality	12.	Management and organization
2.	Delivery	13.	Operating controls
3.	Performance history	14.	Attitudes
4.	Warranties and claim policies	15.	Impression
5.	Price	16.	Packaging ability
6.	Technical capability	17.	Labor relation records
7.	Financial position	18.	Geographical location
8.	Prosedural compliance	19.	Amount of past business
9.	Communication system	20.	Training aids
10.	Reputation in industry	21.	Reciprocal arrangements
11.	Desire for Business	12.	Management and organization



the 5<sup>th</sup> **ICTROPS**

International Conference  
for Tropical Studies and Its Applications



**Analitycal Hierarchy Process (AHP)**

The AHP method, proposed by Thomas L. Saaty, from the Wharton School of Business in 1970. According to Saaty in Putri (2012), AHP is a method used in the decision-making process of complex problems such as: planning, determining alternatives, setting priorities , policy selection, resource allocation, needs determination, needs forecasting, performance planning, optimization, and conflict resolution. A problem is said to be complex if the structure of the problem is not clear and there is no availability of accurate statistical data and information, so that the input used to solve this problem is human intuition. But this intuition must come from people who correctly understand the problem to be solved (experts).

According to Marimin (2004), there are several advantages to using AHP in solving a complex problem, namely as follows: unity, complexity, interdependence, hierarchy, measurement, consistency, synthesis, bargain, assessment and consensus and process repetition.

The stages of decision making using the AHP method, according to Merry et al., (2014) are:

1. Identify the problem, determine the goal and the desired solution.
2. Arrange problems in a hierarchy so that complex problems can be seen clearly. Starting from the objectives, criteria, sub-criteria, and alternatives used.
3. Compile a pairwise comparison matrix for each level. It begins by comparing the criteria with the objectives to be achieved, then comparing the criteria with the sub-criteria in the criteria. Comparisons are made based on the decision makers judgment by assessing the importance level of an element compared to other elements. The comparison matrix can be seen in Table 2. This matrix describes the relative contribution or influence of each element to each goal or criterion level above. The ratio value of  $A_i$  to the element  $A_j$  is  $a_{ij}$ . The A value is determined by the rule: If  $a_{ij} = \alpha$ , then  $a_{ji} = 1/\alpha$ ,  $\alpha \neq 0$  ; If  $A_i$  has the same relative importance as  $A_j$ , then  $a_{ij} = a_{ji} = 1$ ; in particular,  $a_{ii} = 1$ , for all  $i$ .

Table 2. Pairwise Comparison Matrix

<b>C</b>	<b>A<sub>1</sub></b>	<b>A<sub>2</sub></b>	<b>A<sub>3</sub></b>	...	<b>A<sub>n</sub></b>
<b>A<sub>1</sub></b>	$a_{11}$	$a_{12}$	$a_{13}$	...	$a_{1n}$
<b>A<sub>2</sub></b>	$A_{21}$	$A_{22}$	$A_{23}$	...	$A_{2n}$
<b>A<sub>3</sub></b>	$A_{31}$	$A_{32}$	$A_{33}$	...	$A_{3n}$
...	...	...	...	...	...
<b>A<sub>n</sub></b>	$A_{n1}$	$A_{n2}$	$A_{n3}$	...	$A_{nn}$

1. Fill in the pairwise comparison matrix by decision makers based on the weights as shown in table 3.

Table 3. Ratio Weight Scale

<b>Weight</b>	<b>Description</b>
1	Both elements are equally important
3	One element is slightly more important than the other
5	One element is more important than the other
7	One element is clearly more absolutely important than the other
9	One element is absolutely important than the other



the 5<sup>th</sup> ICTROPS

International Conference  
for Tropical Studies and Its Applications



2, 4, 6, 8	The value between two value of adjacent consideration
------------	---

- Calculate the geometric mean. If there is more than one decision maker, then the geometric mean is done. This geometric value is formulated by:

$$GM = n\sqrt{(x_1)(x_2)...(x_n)} \tag{1}$$

- Logical consistency test (CI).
- Test the consistency using the formula  $CR = CI/RI$ , where RI is a random index of consistency. If the consistency ratio  $\leq 0,1$ , the results of the data calculation can be justified.

Technique for Order Preference by Similarity to Ideal Solutions (TOPSIS)

TOPSIS method is a decision-making technique from several possible alternative choices. The purpose of this method is to determine the positive and the negative ideal solution. The positive ideal solution maximizes the benefit criteria and minimizes the cost criteria, while the negative ideal solution maximizes the cost criteria and minimizes the benefit criteria. The greater the value of the benefit criteria, the more feasible it is to be selected. The cost criterion is the opposite of the benefit criterion, the smaller the value of the criterion, the more feasible it is to be selected. In the TOPSIS method, the optimal alternative is the one closest to the positive ideal solution and farthest from the negative ideal solution (Purnomo et al, 2013).

The decision-making stages using the TOPSIS method are:

Develop a decision matrix. The decision matrix X refers to m alternatives that will be evaluated based on n criteria. It can be seen in table 4.

Table 4. Ratio Weight Scale

		$X_1$	$X_2$	$X_3$				$X_n$
$a_1$	X =	$X_{11}$	$X_{12}$	$X_{13}$	.	.	.	$X_{1n}$
$a_2$		$X_{21}$	$X_{22}$	$X_{23}$	.	.	.	$X_{2n}$
$a_3$		$X_{31}$	$X_{32}$	$X_{33}$	.	.	.	$X_{3n}$
.		.	.	.	.	.	.	.
.		.	.	.	.	.	.	.
$a_m$		$X_{m1}$	$X_{m2}$	$X_{m3}$	.	.	.	$X_{mn}$

$a_i = (i = 1, 2, 3, \dots, m)$  are the possible alternatives,

$x_j = (j = 1, 2, 3, \dots, n)$  are the attribute which the alternatives performance are measured,

$x_{ij}$  = alternatives performance  $a_i$  with attribute reference  $x_j$ .

Constructing a Normalized Decision Matrix. The element  $r_{ij}$  is the result of the decision matrix R using the Euclidean length of a vector method as follows:





the 5<sup>th</sup> ICTROPS

International Conference  
for Tropical Studies and Its Applications



$$r_{ij} = \frac{x_{ij}}{\sqrt{\sum_{i=1}^m x_{ij}^2}} \quad (2)$$

Create a weighted normalized decision matrix as follows:

$$v_{ij} = w_j \cdot r_{ij} \quad (3)$$

Determine the positive ideal solution and the negative ideal solution. The positive ideal solution is denoted A+, as follows:

$$A^+ = \left\{ \left( \max v_{ij} \mid j \in J \right), \left( \min v_{ij} \mid j \in J' \right) \right\} = \left\{ v_1^+, v_2^+, v_3^+, \dots, v_n^+ \right\} \quad (4)$$

While the negative ideal solution is denoted A-, as in equation below:

$$A^- = \left\{ \left( \min v_{ij} \mid j \in J \right), \left( \max v_{ij} \mid j \in J' \right) \right\} = \left\{ v_1^-, v_2^-, v_3^-, \dots, v_n^- \right\} \quad (5)$$

Calculating Alternatives. The calculation of separation is a measurement of the distance from an alternative to a positive ideal solution and a negative ideal solution, as in equation 6 and 7 below:

$$S_i^+ = \sqrt{\sum_{j=1}^n (v_{ij} - v_j^+)^2} \quad (6)$$

$$S_i^- = \sqrt{\sum_{j=1}^n (v_{ij} - v_j^-)^2} \quad (7)$$

Calculate the relative closeness to the ideal solution using the following equation:

$$C_i = \frac{S_i^-}{S_i^+ + S_i^-} \quad (8)$$

Ranking alternatives, sorted from the largest C+ value to the smallest value. The alternative with the largest C+ value is the best solution.

### Results and Discussion

Currently X Bakery has 7 suppliers that supply wheat flour, namely A, B, C, D, E, F and G. They have collaborated with X Bakery since 2017. The average flour supply from the suppliers is 250 kg per month. To determine suppliers of flour, there are several criteria required by X bakery, including quality, price, delivery, technical capability, work history, operation control, and communication systems. Details of the criteria and sub criteria set by X Bakery can be seen in table below.

**Table 5. Supplier Criteria and Sub Criteria**

Criteria	Sub Criteria
Quality	The raw material quality
	Conformance specification
	Quality consistency
Price	The raw material price



the 5<sup>th</sup> ICTROPS

International Conference  
for Tropical Studies and Its Applications



	Payment method
Delivery	Delivery time
	Delivery quantity
Communication	Communication type
	Communication consistency
Work history	Ability to keep agreements
	Ability to keep number and time of order
Operation control	Valid data
Technical capability	Ability to meet targets

The pairwise comparison matrix was constructed based on the data from the criteria and sub-criteria weighting questionnaire. The matrix is divided into three parts, the diagonal, the top diagonal, and the bottom diagonal. The bottom of the diagonal is filled with the opposite value of the top of the diagonal, and vice versa. Table 6 shows the matrix.

**Table 6.** The Pairwise Comparison Matrix

Criteria	A1	A2	A3	A4	A5	A6	A7
Quality	1,00	3,00	3,00	5,00	5,00	5,00	5,00
Price	0,33	1,00	3,00	5,00	5,00	2,00	2,00
Delivery	0,33	0,33	1,00	2,00	5,00	2,00	3,00
Communication	0,20	0,20	0,50	1,00	3,00	3,00	2,00
Work history	0,20	0,20	0,20	0,33	1,00	0,33	0,20
Opert control	0,20	0,50	0,50	0,33	3,00	1,00	0,33
Tech capability	0,20	0,50	0,33	0,50	5,00	3,00	1,00

Test of consistency was conducted on the comparison of elements at each level of the hierarchy. The purpose of this test is to see the consistency of comparisons between the criteria carried out for the entire hierarchy. The test results can be seen in Table 7.

**Table 7.** Normalization and Priority

Criteria	A1	A2	A3	A4	A5	A6	A7	Weight	Rank
Quality	0,41	0,52	0,35	0,35	0,19	0,31	0,37	0,356	1
Price	0,14	0,17	0,35	0,35	0,19	0,12	0,15	0,210	2
Delivery	0,14	0,06	0,12	0,14	0,19	0,12	0,22	0,140	3
Communication	0,08	0,03	0,06	0,07	0,11	0,18	0,15	0,0982	4
Work history	0,08	0,03	0,02	0,02	0,04	0,02	0,01	0,034	7
Opert control	0,08	0,09	0,06	0,02	0,11	0,06	0,02	0,064	6
Tech capability	0,08	0,09	0,04	0,04	0,19	0,18	0,07	0,0979	5



the 5<sup>th</sup> **ICTROPS**

International Conference  
for Tropical Studies and Its Applications



After obtaining the weights for each criterion, then a decision matrix is built. The decision matrix contains a comparison of seven alternative suppliers with each criterion. The results of the decision matrix for the selection of wheat flour suppliers can be seen in the following table.

**Table 8.** Supplier Selection Matrix

	A <sub>1</sub>	A <sub>2</sub>	A <sub>3</sub>	A <sub>4</sub>	A <sub>5</sub>	A <sub>6</sub>	A <sub>7</sub>
X <sub>1</sub>	7	7	9	7	7	7	9
X <sub>2</sub>	7	5	5	5	7	5	5
X <sub>3</sub>	7	7	7	9	7	7	7
X <sub>4</sub>	7	7	7	5	7	7	7
X <sub>5</sub>	7	5	5	5	7	5	5
X <sub>6</sub>	5	5	7	7	7	5	5
X <sub>7</sub>	5	7	7	5	7	5	7

From the decision matrix, then a normalized decision matrix is made, which is shown in table 9.

**Table 9.** Normalized Matrix

Alternative	A1	A2	A3	A4	A5	A6	A7
A	0,408	0,425	0,498	0,419	0,378	0,445	0,517
B	0,408	0,304	0,277	0,299	0,378	0,318	0,287
C	0,408	0,425	0,387	0,539	0,378	0,445	0,402
D	0,408	0,425	0,387	0,299	0,378	0,445	0,402
E	0,408	0,304	0,277	0,299	0,378	0,318	0,287
F	0,291	0,304	0,387	0,419	0,378	0,318	0,287
G	0,291	0,425	0,387	0,299	0,378	0,318	0,402

The weighted normalized decision matrix is made by multiplying the results of the priority weights of the AHP criteria with the normalized decision matrix. The weighted normalized decision matrix can be seen in table 10.

**Table 10.** Wighted Normalized Decision Matrix

Alternative	A1	A2	A3	A4	A5	A6	A7
A	0,145	0,089	0,070	0,041	0,013	0,029	0,051
B	0,145	0,064	0,039	0,029	0,013	0,020	0,028
C	0,145	0,089	0,054	0,053	0,013	0,029	0,039
D	0,145	0,089	0,054	0,029	0,013	0,029	0,039
E	0,145	0,064	0,039	0,029	0,013	0,020	0,028
F	0,104	0,064	0,054	0,041	0,013	0,020	0,028
G	0,104	0,089	0,054	0,029	0,013	0,020	0,039



## the 5<sup>th</sup> ICTROPS

International Conference  
for Tropical Studies and Its Applications



Co-Organized by :

The next step is to arrange a positive and a negative ideal solution, calculate the alternative distance from the positive ideal solution ( $S^+$ ) and the alternative distance from the negative ideal solution ( $S^-$ ) and then calculating the relative closeness to the ideal solution. Each of these values can be seen in tables 11, 12 and 13.

**Table 11.** Positive and Negative Ideal Solution

Criteria	$A^+$	$A^-$
A1	0,145	0,104
A2	0,089	0,064
A3	0,070	0,039
A4	0,041	0,029
A5	0,013	0,013
A6	0,029	0,020
A7	0,051	0,028

**Table 12.** Positive and Negative Alternative

Alternative	$S^+$	$S^-$
A	0,0008	0,0633
B	0,0485	0,0411
C	0,0230	0,0577
D	0,0228	0,0525
E	0,0485	0,0411
F	0,0565	0,0195
G	0,0480	0,0316

**Table 13.** Relative Closeness to The Ideal Solutions

Alternative	$C^+$
A	0,9875
B	0,4587
C	0,7149
D	0,6972
E	0,4587
F	0,2565
G	0,3969

The selected suppliers are determined after ranking the  $C^+$  value from the largest to the smallest. The suppliers ranking is A, C, D, B, E, G and F.

### Conclusions

Of the seven supplier selection criteria, quality is the priority criterion by X bakery, while work history gets



## the 5<sup>th</sup> ICTROPS

International Conference  
for Tropical Studies and Its Applications



the lowest weight. This means that X bakery places more emphasis on the performance of current suppliers without compromising the track record of partnering. The supplier that is the priority of X bakery to supply wheat flour is supplier A, because of the seven criteria required by X bakery, supplier A has the largest weight rating.

### REFERENCES

- Ceby, F, & Bayraktar, D. (2003). An Integrated Approach for Supplier Selection, Istanbul, Journal of Logistic Information Management.
- Marimin, (2004), Teknik dan Aplikasi Pengambilan Keputusan Kriteria Majemuk, PT. Grasindo, Jakarta.
- Merry, L., Ginting, M., dan Marpaung, B., (2014), Pemilihan Supplier Buah Dengan Pendekatan Metode Analytical Hierarchy Process (AHP) Dan TOPSIS: Studi Kasus Pada Perusahaan Retail, Jurnal Teknik dan Ilmu Komputer, vol. 03, No. 09, Jakarta.
- Pujawan, N., (2010)., Management Supply Chain, Guna Widya, Surabaya.
- Purnomo, E.N.S., Sihwi, S.W., dan Anggrainingsih, R., (2013), Analisis Perbandingan Menggunakan Metode AHP, TOPSIS, dan AHP-TOPSIS dalam Studi Kasus Sistem Pendukung Keputusan Penerimaan Siswa Program Akselerasi, Jurnal ITSMART, vol 2, No.1, ISSN: 2301–7201, Surakarta.
- Putri, C.F., (2012), Pemilihan Supplier Bahan Baku Pengemas Dengan Metode AHP (Analytical Hierarchy Process), Widya Teknika, vol.20, No.1, ISSN 1411 – 0660 : 25 – 31, Malang.
- Saaty, T.L., Pengambilan Keputusan Bagi Para Pemimpin, (1991), Pustaka Binaman Presindo.
- Sesa, L.A., Sitania, F.D., Widada, D., (2021) Analisis Pemilihan Supplier Bahan Baku Roti dengan Metode ANP (Analytic Network Process) dan Rating Scale (Studi Kasus Roti Gembong Kota Raja Balikpapan), Jurnal Optimalisasi, Volume 7 No. 1, E-ISSN: 2502 0501.
- Wirdianto, E., Unbersa, E., 2008, Aplikasi Metode Analytical Hierarchy Process dalam menentukan Kriteria Penilaian Supplier, Teknika, vol. 2, No. 29, ISSN: 0854-8471, Padang.

## TNP-422

### Hemagglutinins Inhibitors from Tropical Medicinal Plants Used in Sudan

**Sara Ahmed<sup>1,2\*</sup>, Mohamed Mutasem<sup>3</sup>, Atsushi Ishihara<sup>4</sup>, Jiro Arima<sup>4</sup>**

1. The United Graduate School of Agricultural Sciences, Faculty of Agriculture, Tottori University, Japan
2. Nutrition and Health Centre for Training and Research, Ahfad University for Women, Khartoum, Sudan.
3. Department of Food Science and Technology, Faculty of Agriculture, University of Khartoum, Sudan.
4. Department of Life and Environmental Agricultural Sciences, Faculty of Agriculture, Tottori University, Japan.

Corresponding Author\*: [saraahmed8611@gmail.com](mailto:saraahmed8611@gmail.com)

#### Abstract

Virulence factors are molecules that support the formation and preservation of various bacterial or viral pathogens on the host tissues. Consequently, these virulence factors are believed to harm the host through numerous mechanisms. Hemagglutinins are a large class of virulence factors associated with several diseases including cardiovascular diseases, diabetes, periodontal diseases, and even Covid-19. *Porphyromonas gingivalis* bacteria produce several virulence factors comprising large molecules of proteins identified as hemagglutinins which lead to different diseases. These proteins are vital molecules that allow *P. gingivalis* to adhere to the host cell then uptake iron and heme by attaching, aggregate, and lyse erythrocytes to facilitate bacterial survival and maturation. In order to prevent the adherence of *P. gingivalis* to the host tissues, and to block the aggregation of erythrocytes, we focused on the inhibition of the hemagglutinating activity of *P. gingivalis*, by plants extracts from tropical regions used in Sudanese traditional medicine. In this study, we aimed to evaluate the aqueous extracts of dry, powder seeds from *Monechma ciliatum*, *Monechma debile*, and *Prunus mahaleb* for in vitro activity against the hemagglutination of *P. gingivalis*. using the inhibition assay as the experimental model. All extracts have inhibitory activity against hemagglutination. Nonetheless, *M. ciliatum* seeds water extract shows potent inhibitory activity against the tested assay with MIC value 0.03 mg/mL. Subsequently, the water extracted from dry powdered seeds of *M. ciliatum* was partitioned using ethyl acetate followed by reversed-phase chromatography, thin-layer chromatography, ESI-MS, and NMR analysis resulting in the isolation of four compounds which identified as oleic acid, coumarin, 1,2-dioleoylglycerol, and 1,3-dioleoylglycerol with MICs of 15-100 µg/mL against hemagglutination. We believe that isolation and identification of the inhibitor materials from *M. ciliatum* seeds will develop a new therapeutic agent against hemagglutinins in which might help to delay or control numerous systemic diseases through the interaction with the virulence factors.

**Keywords:** Virulence factors, Hemagglutination, *M. Ciliatum*, *M. debile*, *P. mahaleb*, *P. gingivalis*.



the 5<sup>th</sup> ICTROPS

International Conference  
for Tropical Studies and Its Applications

Islamic Development Bank 4in1 Project  
Project Implementation Unit  
University of Mulawarman



IsDB  
البنك الإسلامي للتنمية  
Islamic Development Bank



## Introduction

Virulence factors are the most tools of several pathogens to harm the host through various mechanisms (Connolly et al., 2017). Of them hemagglutinins are a large class of virulence factors associated with several diseases including cardiovascular diseases, diabetes, periodontal diseases, and even Covid-19 (Patel et al., 2021; Potempa, and Olczak, 2008; Perdue and Suarez, 2000). *Porphyromonas gingivalis* bacteria produce several virulence factors comprising large molecules of proteins identified as hemagglutinins which lead to different diseases. These proteins are vital molecules that allow *P. gingivalis* to adhere to the host cell then uptake iron and heme by attaching, aggregate, and lyse erythrocytes to facilitate bacterial survival and maturation (Connolly et al., 2017; Potempa, and Olczak, 2008). In order to prevent the adherence of *P. gingivalis* to the host tissues, and to block the aggregation of erythrocytes, we focused on the inhibition of the hemagglutinating activity of *P. gingivalis*, by plants extracts from tropical regions used in Sudanese traditional medicine.

In this study, we aimed to evaluate the aqueous extracts of dry, powder seeds from three tropical medicinal plants (TMP) which are *Monechma ciliatum*, *Monechma debile*, and *Prunus mahaleb* for in vitro activity against the hemagglutination of *P. gingivalis*. *M. ciliatum* or black mahlab, and *M. debile* or red mahlab belonging to the family Acanthaceae, they are famous medicinal plant that grows in some parts of arid and semi-arid lands in tropical Africa including western Sudan, especially in the Nuba Mountains and Gabel Mara area (Oshi and Abdelkarim, 2013; Sharief, 2002). *P. mahaleb* or white mahlab is belonging to the family Rosaceae is found wild throughout the Mediterranean zone, as well as Eastern Europe, West Asia and some tropical areas. (Farag et al 2021; Zjhra and Kaplin, 2004). It is used as spice which derived from the seeds contained within the cherry stones that is used to season sweet confections in Eastern Mediterranean countries (Farag et al 2021). In Sudan, crushed kernels of black, red, and white mahlabs are used as food flavouring agents, as well, it used to manufacture traditional fragrances and for nourishing hair lotions in wedding preparations. In addition, consumption of soaked mahlab seed is considered a remedy for the treatment of diarrhea in children and other gynaecological problems (Darbyshire et al., 2020; Alma et al., 2012; Mariod et al., 2009; Sharief, 2002). Conversely, despite its different traditional uses, few studies have genuine its use in folk medicine and determined the bioactive compounds responsible for their potential effects. Consequently, in this study, we investigated the role of dried seeds components against the hemagglutinins activity of *P. gingivalis* following aqueous extraction. The inhibitory activities of the four compounds isolated and purified *M. ciliatum* seeds are discussed.

## Methodology

### Preparation of aqueous extract of the selected tropical medicinal plants (TMP) seeds

The selected TMP was *M. ciliatum*, *M. debile*, and *P. mahaleb* seeds (Figure 1). Samples were obtained from the local spices market at Khartoum State, Khartoum, Sudan. Then, the seeds were authenticated at the Faculty of Agriculture, University of Khartoum. Soluble compounds were extracted using distilled water (three times) from cleaned and powdered seeds (1 g sample: 10 ml water) for 30 min at room

temperature under slow shaking. The supernatants were collected by filtration followed by centrifugation then lyophilized and extracted materials were stored at -20°C until analysis.

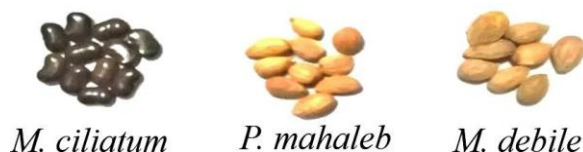

**Figure 1.** The seeds of selected tropical medicinal plants (TMP) used in Sudanese traditional medicine

### Cultivation of *P. gingivalis*

*P. gingivalis* TDC60 (Watanabe et al., 2011) was provided by the RIKEN Bio-Resource Center via the National Bio-Resource Project of the Ministry of Education, Culture, Sports, Science and Technology, Japan. The bacterium was grown in Tryptic Soy Blood Agar medium (Agar Base EH) supplemented with hemin (5 mg/L), menadione (1 mg/L), and horse blood at 37°C under anaerobic conditions for 4-5 days (Gao et al., 2010; Rangarajan, Aduse-Opoku, Paramonov, Hashim, and Curtis, 2017). Then, the cells were inoculated into 5 ml of GAM broth medium and incubated under anaerobic conditions at 37°C for 2-3 days until the middle stationary phase of bacterial growth. The growth rate was evaluated by a spectrophotometer at 600 nm and the cells were removed by centrifugation. The collected culture supernatant was named Sup-Pg, which were used for the inhibition assays.

### Inhibition of hemagglutination

Erythrocyte aggregation (hemagglutination) was performed following the method mentioned by Saiki and Konishi (2007), with slight modifications. The horse defibrinated blood (Cosmo Bio Co., Ltd., Tokyo) was rinsed three times with phosphate buffer saline (PBS) via pipette prior to centrifugation for 5 min at 2,000 × g. The washed erythrocytes were used for the hemagglutination assay after dilution to 5% (v/v) with PBS. The hemagglutination test was performed in a 96-well microtiter plate (round bottom) using a reaction mixture consisting of 80 µl of PBS, 10 µl of Sup-Pg, and 10 µl of TMP seeds aqueous extract. The mixture was shaken thoroughly and incubated for 10 min at room temperature. Then 100 µl of 5% blood was added to the assay mixture. Hemagglutination was evaluated visually after 2 hr of incubation at room temperature. PBS was used instead of Sup-Pg and aqueous extract of selected TMP seeds as a negative control. The minimum inhibitory concentration was calculated from the final concentration of the lowest dilution with complete inhibitory activity.





the 5<sup>th</sup> ICTROPS

International Conference  
for Tropical Studies and Its Applications

Islamic Development Bank 4in1 Project  
Project Implementation Unit  
University of Mulawarman



IsDB  
البنك الإسلامي للتنمية  
Islamic Development Bank



### Minimum inhibitory concentration

The dried extracts were used to prepare a stock solution of 1 mg/mL. Each extract was diluted directly in a microplate with a round bottom containing the hemagglutination assay reaction mixture to obtain a final concentration ranging from 100 to 6 mg/mL. The MIC was calculated from the lowest concentration of the extract that completely inhibited the hemagglutination activity. The experiment was conducted in triplicate. A similar method of MIC value determination conducted for the *M. ciliatum* purified compounds.

## Results and Discussion

In the very early stages of inflammation, most of pathogens adhere to the host surface cells through numerous virulent mechanisms, to get their nutrition enabling them to survive and grow. Hence, prevention and remediation of their adherence is a one of the recent strategies to hinder bacterial colonization and subsequent tissue inflammation (Labrecque, Bodet, Chandad, and Grenier, 2006; Wittschier, Faller, and Hensel, 2009; Wittschier et al., 2007). Natural products are known since long time ago with their anti-bacterial and anti-inflammatory properties. These natural compounds identified as alternative and new therapeutic agents to suppress various infections and diseases. *P. gingivalis* cause several health complications via hemagglutinin proteins, that facilitating acquisition of heme and other nutrient by aggregating to the erythrocytes. Consequently, the use of antiadhesive compounds that influence the interaction between hemagglutinins and erythrocyte proteins could hinder the inflammation in the very early stages (Miyachi, Ishihara, Kimizuka, and Okuda, 2007; Yokoyama et al., 2007). In this study we attempted to evaluate the inhibitory activity of *M. ciliatum*, *M. debile*, and *P. mahaleb* seeds aqueous extracts on hemagglutinins of *P. gingivalis* TDC60. The extracts were tested in different concentrations, between 100-6 mg/mL. *M. ciliatum*, *M. debile*, and *P. mahaleb* seeds revealed potent anti-hemagglutination activity with MIC values 6, 25, and 12 mg/mL, respectively (Figure 2). This results, reporting for the first time the inhibitory activity of the selected TMP against hemagglutinins. Additionally, the selected TMP contain aromatic components and a high amount of oils. Thus, this plant is used mainly as a flavouring agent in breads, cookies, and traditional Sudanese bread sheet (kisra), to give a sweet aroma to the final product. (Darbyshire et al., 2020; Alma et al., 2012; Sharief, 2002). Thus, its medical effects will enhance their uses.

*M. ciliatum* seeds aqueous extract exposed the lowest MIC value, which revealed the highest inhibitory activity. The inhibitor materials from *M. ciliatum* seeds aqueous extract were purified through several chromatography methods, and identified by ESI-MS, and NMR analysis as it detailed in Eltigani et al., (2019), resulting in the isolation of four compounds identified as oleic acid, coumarin, 1,2-dioleoylglycerol, and 1,3-dioleoylglycerol, with MICs of 15, 50, and 100 µg/mL against hemagglutination (Table 1). *M. ciliatum* identified by western Sudanese people as a natural pain killer for liver and stomach pains (Mariod, Aseel, Mustafa, & Abdel-Wahab, 2009). In addition, constituents of this plant have been shown to have anti-cytotoxic properties (Uguru & Evans, 2000).

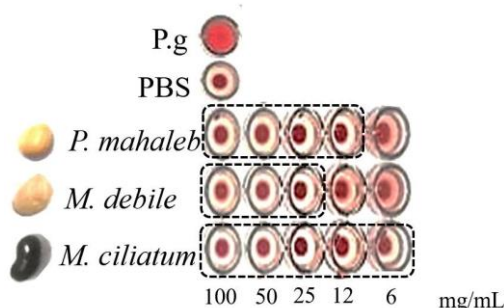

**Figure 2.** Hemagglutinin inhibition by the aqueous extract of the selected tropical plants

Oleic acid and coumarins found in numerous plant species (Mariod et al., 2009; Rosselli et al., 2009; Spino, Dodier, and Sotheeswaran, 1998) Furthermore, we found other two compounds classified as diacylglycerols (1,2-dioleoylglycerol, and 1,3-dioleoylglycerol) from *M. ciliatum*. These compounds, which exist in several vegetable and seed oil, are well known for their functional roles in medicinal fields (AlAttas, Zahran, and Turkistany, 2016; Huang, Altimova, Myers, and Ebersole, 2011). However, and to the best of our knowledge, these compounds are very rare in higher plants. Therefore, the identification and isolation of 1,2- and 1,3- dioleoylglycerols from *M. ciliatum* will be a useful and cost-effective source of these bioactive compounds for therapeutic use, especially for people in tropical areas of Africa. From this study, isolated oleic acid has inhibitory activity with a MIC value of 15  $\mu\text{g}/\text{mL}$ , while 1,2- and 1,3-dioleoylglycerols showed weaker inhibitory activities with a MIC value of 100  $\mu\text{g}/\text{mL}$  (Table 1). These results agree with the findings of Huang et al. (2011). Their group found some correlation between the antimicrobial activities of fatty acids and their structure, and that the modification of the fatty acid carboxyl group might significantly influence the inhibitory activities. Coumarins are phenolic compounds that are famous as potential therapeutic agents for treating several diseases. These compounds have been reported for their ability to inhibit *P. gingivalis* growth and MMP-9 collagenase (Marquis, Genovese, Epifano, and Grenier, 2012). In this study, the isolated coumarin inhibited *P. gingivalis* hemagglutinins, which are vital adherence molecules for iron and heme uptake via attachment, aggregation, and lysis of erythrocytes (Gao et al., 2010; Smalley et al., 2011). Some reports have shown that coumarins possess iron-chelating properties (Mladenka et al., 2010). Therefore, the inhibition activity of the isolated coumarin might be related to the chelation of iron in the reaction mixture, which then made iron unavailable for virulence factors.

**Table 1.** Hemagglutinins inhibition activity of isolated compounds in comparison with standard compounds

Isolates	MIC ( $\mu\text{g}/\text{mL}$ )	Standards	MIC ( $\mu\text{g}/\text{mL}$ )
Compound 1	50	Coumarin	100
Compound 2	15	Oleic acid	$\leq 15$
Compound 3	$\leq 100$	1,2-Diolein	$\leq 100$
Compound 4	100	1,3-Diolein	100

## Conclusions

The water extracts of the selected TMP can play a potent role in blocking the very early stages of *P. gingivalis* virulent via hemagglutinin inhibition. Thus targeting those virulent factors might hinder pathogenicity and improve the expansion of new, safe, effective therapeutic and/or preventative agents. *M. ciliatum* seeds, inhibited of *P. gingivalis* hemagglutinin with very low MIC value, compared to *M. debile*, and *P. mahaleb*. This plant has a very pleasant aroma and contains valuable compounds associated with hemagglutinins inhibition, in addition to its economically low cost, which supports further therapeutic use.

## REFERENCES

- AlAttas, S. A., Zahran, F. M., & Turkistany, S. A. (2016). Nigella sativa and its active constituent thymoquinone in oral health. *Saudi Medical Journal*, 37, 235–244. doi.org/10.15537/smj.2016.3.13006
- Alma, M. H., EyyüpKaraogul, Ertas, M., Altuntas, E., Karaman, S., and Diraz, E. (2012). Chemical Composition of Seed Oil from Turkish Prunus mahaleb L. *Analytical Chemistry Letters*, 2, 182-185. doi: 10.1080/22297928.2000.10648267
- Connolly, E., Millhouse, E., Doyle, R., Culshaw, S., Ramage, G., & Moran, G. P. (2017). The Porphyromonas gingivalis hemagglutinins HagB and HagC are major mediators of adhesion and biofilm formation. *Molecular Oral Microbiology*, 32, 35–47. doi.org/10.1111/omi.12151
- Darbyshire, I., Kiel, K. A., Astroth, C. M., Dexter, K. G., Chase, F. M., and Tripp, E.A. (2020). Phylogenomic Study of Monechma Reveals Two Divergent Plant Lineages of Ecological Importance in the African Savanna and Succulent Biomes. *Diversity*, 12, 237. doi:10.3390/d12060237
- Eltigani, S. A., Eltayeb, M. M., Ishihara, A., and Arima, J. (2019). Isolates from Monechma ciliatum seeds' extract hampered Porphyromonas gingivalis hemagglutinins. *Journal of Food Biochemistry*, 43, e13029. doi.org/10.1111/jfbc.13029.
- Eltigani, S. A., Eltayeb, M. M., Tomohiro, B., Ishihara, A., and Arima, J. (2019). Non-specific Inhibitor from Origanum vulgare Leaves Restrains Porphyromonas gingivalis Growth and Virulence Factors. *International Journal of Agriculture and Biology*, 23, 1068-1074. doi.org/10.17957/IJAB/15.1388.
- Farag, M. A., Khattab, R. K., Shamma, S., and Afifi, S. M. (2021). Profiling of Primary Metabolites and Volatile Determinants in Mahlab Cherry (Prunus mahaleb L.) Seeds in the Context of Its Different Varieties and Roasting as Analyzed Using Chemometric Tools. *Foods*, 10, 728. https://doi.org/10.3390/foods10040728
- Gao, J. L., Nguyen, K. A., & Hunter, N. (2010). Characterization of a hemophore-like protein from Porphyromonas gingivalis. *Journal of Biological Chemistry*, 285, 40028–40038. doi.org/10.1074/jbc.M110.163535
- Huang, C. B., Altimova, Y., Myers, T. M., & Ebersole, J. L. (2011). Short and medium-chain fatty acids exhibit antimicrobial activity for oral microorganisms. *Archives of Oral Biology*, 56, 650–654. doi.org/10.1016/j.archo.oralbio.2011.01.011



the 5<sup>th</sup> ICTROPS

International Conference  
for Tropical Studies and Its Applications

Islamic Development Bank 4in1 Project  
Project Implementation Unit  
University of Mulawarman



IsDB  
البنك الإسلامي للتنمية  
Islamic Development Bank



- Labrecque, J., Bodet, C., Chandad, F., & Grenier, D. (2006). Effects of a high-molecular-weight cranberry fraction on growth, biofilm formation and adherence of *Porphyromonas gingivalis*. *Journal of Antimicrobial Chemotherapy*, 58, 439–443. doi.org/10.1093/jac/dkl220
- Mariod, A. A., Aseel, K. M., Mustafa, A. A., & Abdel-Wahab, S. I. (2009). Characterization of the seed oil and meal from *Monechma ciliatum* and *Prunus mahaleb* seeds. *Journal of the American Oil Chemists Society*, 86, 749–755. doi.org/10.1007/s11746-009-1415-2
- Marquis, A., Genovese, S., Epifano, F., & Grenier, D. (2012). The plant coumarins auraptene and lacinartin as potential multifunctional therapeutic agents for treating periodontal disease. *BMC Complementary and Alternative Medicine*, 12, 80. doi.org/10.1186/1472-6882-12-80
- Miyachi, K., Ishihara, K., Kimizuka, R., & Okuda, K. (2007). Arg-gingipain a DNA vaccine prevents alveolar bone loss in mice. *Journal of Dental Research*, 86, 446–450. doi.org/10.1177/154405910708600511
- Mladenka, P., Macakova, K., Zatloukalova, L., Rehakova, Z., Singh, B. K., Prasad, A. K., Saso, L. (2010). In vitro interactions of coumarins with iron. *International Journal of Biochemistry and Molecular Biology*, 92, 1108-1114. doi.org/10.1016/j.biochi.2010.03.025
- Olczak, T., Sroka, A., Potempa, J., & Olczak, M. (2008). *Porphyromonas gingivalis* HmuY and HmuR: Further characterization of a novel mechanism of heme utilization. *Archives of Microbiology*, 189, 197-210. doi.org/10.1007/s00203-007-0309-7
- Oshi, M. A., & Abdelkarim, M. A. (2013). Phytochemical screening and evaluation of *Monechma ciliatum* (black mahlab) seed extracts as antimicrobial agents. *Avicenna Journal of Phytomedicine*, 3, 126-134.
- Patel, C. N., Kumar, S. P., Pandya, H.A., and Rawa, R. M. (2020). Identification of potential inhibitors of coronavirus hemagglutinin-esterase using molecular docking, molecular dynamics simulation and binding free energy calculation. *Molecular Diversity*, 25, 421-433. doi: 10.1007/s11030-020-10135-w.
- Perdue, M., and Suarez, D. (2000). Structural features of the avian influenza virus hemagglutinin that influence virulence. *Veterinary Microbiology*, 74, 77-86.
- Rangarajan, M., Aduse-Opoku, J., Paramonov, N. A., Hashim, A., & Curtis, M. A. (2017). Hemin binding by *Porphyromonas gingivalis* strains is dependent on the presence of A-LPS. *Molecular Oral Microbiology*, 32, 365–374. doi.org/10.1111/omi.12178
- Rosselli, S., Maggio, A. M., Faraone, N., Spadaro, V., Morris-Natschke, S., Bastow, K. F., ... Bruno, M. (2009). The cytotoxic properties of natural coumarins isolated from roots of *Ferulago campestris* (Apiaceae) and of synthetic ester derivatives of aegelinol. *Natural Product Communications*, 4, 1701–1706. doi.org/10.1177/1934578X0900401219
- Sharief, M. T. (2002). The effect of sowing date and plant spacing on growth and yield of black mahlab (*Monechma ciliatum*). MSc Thesis. Khartoum, Sudan: University of Khartoum.
- Smalley, J. W., Byrne, D. P., Birss, A. J., Wojtowicz, H., Sroka, A., Potempa, J., & Olczak, T. (2011). HmuY haemophore and gingipain proteases constitute a unique syntrophic system of haem acquisition by *Porphyromonas gingivalis*. *PLoS ONE*, 6, e17182. doi.org/10.1371/journal.pone.0017182
- Spino, C., Dodier, M., & Sotheeswaran, S. (1998). Anti-HIV coumarins from *calophyllum* seed oil.



the 5<sup>th</sup> ICTROPS

International Conference  
for Tropical Studies and Its Applications

Islamic Development Bank 4in1 Project  
Project Implementation Unit  
University of Mulawarman



IsDB  
البنك الإسلامي للتنمية  
Islamic Development Bank



- Bioorganic and Medicinal Chemistry Letters,8, 3475–3478. doi.org/10.1016/S0960- 894X(98)00628-3
- Uguru, M. O., & Evans, F. (2000). Phytochemical and pharmacological studies on *Monechma ciliatum*. *Journal of Ethnopharmacology*, 73, 289–292. doi.org/10.1016/S0378- 8741(00)00236-1
- Wittschier, N., Faller, G., & Hensel, A. (2009). Aqueous extracts and polysaccharides from liquorice roots (*Glycyrrhiza glabra* L.) inhibit adhesion of *Helicobacter pylori* to human gastric mucosa. *Journal of Ethnopharmacology*, 125, 218–223. doi.org/10.1016/j. jep.2009.07.009
- Wittschier, N., Lengsfeld, C., Vortheims, S., Stratmann, U., Ernst, J. F., Verspohl, E. J., & Hensel, A. (2007). Large molecules as antiadhesive compounds against pathogens. *Journal of Pharmacy and Pharmacology*, 59, 777–786. doi.org/10.1211/jpp.59.6.0004
- Yokoyama, K., Sugano, N., Shimada, T., Shofiqur, R. A., Ibrahim, S. M., Isoda, R., ... Ito, K. (2007). Effects of egg yolk antibody against *P. gingivalis* gingipains in periodontitis patients. *Journal of Oral Science*, 49, 201–206. doi.org/10.2334/josnu sd.49.201
- Zjhra M. L., and Kaplin, B. A. (2004). Reproductive Biology and Genetics of Tropical Trees from a Canopy Perspective. *Physiological Ecology*, CHAPTER 20 - 397-412. doi.org/10.1016/B978-012457553-0/50026-5

## TNP-429

# Crystal Structure, Mineral Content, $\beta$ -Carotene, $\alpha$ -Tocopherol, Antioxidant and Functional Group Active of Pre-gelatinization and Pre-Digest White and Red Rice Flour from East Kalimantan as Source of Anti-Stunting Nutrients

**Panggulu Ahmad Ramadhani Utoro\***, Miftakhur Rohmah, Nur Amaliah, Anton Rahmadi, Rusdiansyah

Department of Agricultural Product Technology, Mulawarman University

*Corresponding Author\*: pangguluahmad859@gmail.com*

### Abstract

Stunting is a priority national research agenda, as a focus discussion in the 2018 National Food Workshop. Strategic Plane of LP2M Mulawarman University places food as one of the nine priorities of Unmul for 2021-2024. Red rice is a food that contains a lot of  $\beta$ -carotene and  $\alpha$ -tocopherol. Vitamin E in white rice depends on the milling degree because the composition of vitamins is generally in the layer of rice bran. The aims of this study are: (1) to characterize the content of  $\beta$ -carotene,  $\alpha$ -tocopherol, minerals, and antioxidants in 30 local red and white rice cultivars from East Kalimantan; (2) The 2 best red rice and white rice cultivars selected based on the content of  $\beta$ -carotene,  $\alpha$ -tocopherol, minerals and antioxidants, and (3) Observing the effect of processing rice into rice flour using the conventional technique, Pre-Gelatinization, Pre-Digest and the combination of Pre-Gelatinization and Pre-Digest as raw materials for anti-stunting processed food. The parameters observed consisted of functional group (FTIR), crystallinity (XRD), morphology (SEM), gelatinization profile (RVA),  $\beta$ -carotene,  $\alpha$ -tocopherol, minerals, and antioxidants.

**Keywords:** Anti-Stunting, Red rice, White rice.

### Introduction

The problem of stunting is still a big challenge for Indonesia. Indonesia's prevalence of stunting in 2018 was ranked 108<sup>th</sup> out of 132, while in the Southeast Asia Region, Indonesia's prevalence of stunting was second highest after Cambodia. The prevalence rate of stunting in Indonesia is still above the threshold set by WHO, which is 20 percent (Directorate of Non-infectious Diseases Control, Ministry of Health, Republic of Indonesia). East Kalimantan is one of the provinces that has a high prevalence rate, reaching 27,1 percent. Fulfilling nutritional needs from pregnancy and up to 6 months of age is very important, in addition to breast milk, fulfilling micro and macro nutrition according to WHO recommendations. Stunting is a priority national agenda's research, especially as a focus discussion on the 2018 National Workshop in Food.

One of the efforts to prevent stunting is to provide functional food intake based on  $\beta$ -carotene and  $\alpha$ -tocopherol at the age of 1000 days of growth. On this basis, the processing of East Kalimantan Local Rice Flour rich in  $\beta$ -carotene and  $\alpha$ -tocopherol as raw materials for stunting prevention food products is necessary after being

investigated. East Kalimantan has germplasm rich in various varieties of Local Red and White Rice. Red rice contains a lot of  $\beta$ -carotene and  $\alpha$ -tocopherol. The vitamin E in white rice depends on the milling degree because the composition of vitamins is generally in the layer of rice husk (rice bran). Rice is one of the main staple foods throughout the world, in several places such as East Kalimantan, red rice varieties are developed and collected into germplasm as a source of vitamin-A which can be used as a food source to prevent vitamin deficiency (Qamar et al., 2021). The promotion of planting and consumption of red rice and white rice low of milling degree can be carried out in several stages, such as registration of varieties (protection of specific plant varieties), proving the content of pro-vitamin A and vitamin E, and utilization of red rice by industry and recommendations of nutritionists (Dubock, 2019).

Antioxidants are protective compounds that reduce oxidative damage to cells and play a key role in preventing aging and promoting human health. Rice is a staple food containing antioxidant compounds, such as phenolic acids, flavonoids, anthocyanins, proanthocyanidins, carotenoids, and tocopherols (Zhu et al., 2021). Red rice and low milling degree white rice contain a lot of pro-vitamin A and vitamin E. In particular, the biosynthesis of rice rich in  $\beta$ -carotene and  $\alpha$ -tocopherol is centered on psy-genes as found in corn. After the identification phase of the ideal germplasm, the availability and development of rice germplasm, especially red rice, can be carried out by involving cross-breeding techniques and trans-genetic biofortification (De Steur et al., 2017). The growth and maintenance of the macular eye is another role of  $\beta$ -carotene. In addition,  $\beta$ -carotene plays a role in bone growth and increases in height (Zhu et al., 2021). However, stability and synergistic effect on growth,  $\beta$ -carotene needs to be accompanied by lutein,  $\beta$ -carotene,  $\alpha$ -tocopherol, and tocotrienols. These compounds were combined into lipophilic bioactive as stunting prevention (Qamar et al., 2020). Vitamin A is one of the essential micronutrients needed by the body to support growth, maintenance of vision, and cell and embryo development (Tang, 2010). Vitamin A deficiency has been indicating to occur in the under-five community from Indonesian society, especially in East Kalimantan, since two decades ago based on the results of previous research. In fact, East Kalimantan has the potential for local red rice and white rice. The vitamin A content of red rice is quite high, while in order to maximize the vitamin content of white rice, it is possible to reduce the level of milling degree. The aims of this study are: (1) to characterize the content of  $\beta$ -carotene,  $\alpha$ -tocopherol, minerals, and antioxidants in 30 local red and white rice cultivars from East Kalimantan; (2) The 2 best red rice and white rice cultivars selected based on the content of  $\beta$ -carotene,  $\alpha$ -tocopherol, minerals and antioxidants, and (3) Observing the effect of processing rice into rice flour using the conventional technique, Pre-Gelatinization, Pre-Digest and the combination of Pre-Gelatinization and Pre-Digest as raw materials for anti-stunting processed food.

## Methodology

### Time and Place

This research will carry out for five months in 2021 start from material preparation to sample analysis. This research will carry out in the Post Harvest and Handling Laboratory, Chemistry and Biochemistry Agricultural Product, Department of Product Technology, Faculty of Agriculture, Mulawarman University.



the 5<sup>th</sup> ICTROPS

International Conference  
for Tropical Studies and Its Applications

Islamic Development Bank 4in1 Project  
Project Implementation Unit  
University of Mulawarman



IsDB  
البنك الإسلامي للتنمية  
Islamic Development Bank



## Materials and Tools

The main materials of this study consisted of 30 cultivars of red rice and white rice Local origin from East Kalimantan, Pro-grade chemicals needed include Ethanol absolute, DiethylEther, Folin-ciocalteu, Ethyl Acetate, Methanol 2,2-diphenyl-1-picrylhydrazyl (DPPH), folin ciocalteu, Na<sub>2</sub>HPO<sub>4</sub>, NaH<sub>2</sub>PO<sub>4</sub>, -tocopherol, -carotene, ascorbic acid, quercetin, gallic acid

## Procedures

This research is dividing into three stages, namely: (1) Characterization content of  $\beta$ -carotene (Bohari *et al.*, 2018),  $\alpha$ -tocopherol (Bohari *et al.*, 2018), minerals (Rohmah, *et al.*, 2020; Rohman, 2016) and antioxidants (Rahmadi, 2018) in 30 cultivars of brown rice and rice local white originating from East Kalimantan; (2) Selecting two rice cultivars each the best brown and white rice based on the content of  $\beta$ -carotene,  $\alpha$ -tocopherol, minerals and antioxidants; and (3) Observing the effect of processing rice into rice flour using conventional techniques and Pre-Gelatinization, as raw materials for anti-stunting processed food.

## Analysis

### Determination of $\alpha$ -tocopherol

The determination of  $\alpha$ -tocopherol was accomplished by interpolating the absorbance of the sample with a standard calibration curve of  $\alpha$ -tocopherol at a wavelength of 291 nm (Rayleigh model UV 2601, China). The  $\alpha$ -tocopherol standard (Sigma-Aldrich cat. no. T3251-25G, UK) was prepared in absolute ethanol (Smartlab cat. no. A1035, Indonesia) with various concentrations of 50. 75. 100. 125 and 150 mg/L in 10 mL of absolute ethanol. Blank sample was prepared without containing the active substance of  $\alpha$ -tocopherol (Bohari 2018).

### Determination of total carotenoid

Prepared standard solution of pure  $\beta$ -carotene with petroleum ether solvent with concentrations of 5, 10, 15, 20, and 25 ppm. One of the concentrations of raw materials is taken, the absorption is measured in the wavelength range of 400-500 nm. The wavelength that shows the high absorption value is the maximum wavelength. The absorption of each standard solution of  $\beta$ -carotene was measured using an ultraviolet-visible spectrophotometer (UV-VIS) at the maximum wavelength. The standard curve was made with the absorption at the ordinate and the concentration of -carotene at the abscissa. Samples that have been extracted with petroleum ether were measured for absorption using an ultraviolet-visible spectrophotometer (UVVIS) at the maximum wavelength of pure -carotene (Rohman, 2016)

### Antioxidant activity

The antioxidant activity test was performed by spectrophotometric method (Farhan *et al.*, 2012) by calculating the inhibition of 2,2-diphenyl-1-picrylhy-drazyl (DPPH) (Sigma-Aldrich, Germany) reduction. A total of 1 mL of diluted extract in ethanol was added to 1 mL of DPPH (0.15 mM in ethanol) and at the same time, a control consisting of 1 mL DPPH with 1 mL of ethanol was prepared. The solution was well mixed and then incubated in the dark at room temperature for 30 minutes. The absorbance was measured at 517 nm. The DPPH capability of the extract was calculated using equation



1:

$$\% \text{ antioxidant activity} = \frac{\text{control absorbance} - \text{sample absorbance}}{\text{control absorbance}} \times 100 \quad (1)$$

where, the absorbance of the control was the absorption of DPPH + ethanol, the absorbance of the sample was the absorbance of the radical DPPH + sample.

The obtained data was presented with IC50 value, and the value was obtained from linear regression % -DPPH inhibition of sample compound (0, 100, 200, 400, 600 dan 800 ppm). The linear regression equation is calculated as in equation 2 and equation 3.

$$Y = 50 = A x + B \quad (2)$$

$$x = \frac{50 - B}{A} \quad (3)$$

where, Y is IC50 constant value (50), A is The coefficient on the variable x, B is constants and x is IC50 value in ppm (Rahmadi, 2019)

#### Fourier Transform Infra Red (FTIR)

The FTIR spectra of white and red rice were obtained by using a Thermo Nicolet i50 FT-IR spectrometer (Waltham, MA, USA). The analysis was conducted by using attenuated total reflectance (ATR) with ZnSe crystals and deuterated triglycine sulfate detector, using a small amount of the samples in the range of 650–4000  $\text{cm}^{-1}$  with a resolution of 4  $\text{cm}^{-1}$  and 32 iterations (Rohmah 2020).

#### XRD Characterization

XRD analysis was performed by X-ray scattering with a scan speed of 2°/min, in the range:  $2\theta = 3.00\text{-}40.00^\circ$ . The X-ray source was a 2.2 kW Cu anode (40 kV, 40 mA radiation, Cu-K,  $\lambda = 0.15406 \text{ nm}$ ). Prior to measurements, the NLC samples were lyophilized to evaporate water (Rohman, 2016).

#### ACKNOWLEDGEMENT

The author would like to thank to IsDB funding program for research.

#### REFERENCES

Bohari, Muhadir. M. & Rahmadi, A. (2018). Vacuum evaporation and nitrogen-assisted deodorization affects the antioxidant capacity in the olein fraction of red palm oil and its emulsion products. *F1000Research*. 7(1729).

De Steur, H., Blancquaert, D., Stove, C., Lambert, W., Van Der Straeten, D., & Gellynck, X. (2017). Should GM rice with nutrition benefits Be deployed? Findings from biotech and socio economic research. *Genetically Modified Organisms in Developing Countries: Risk Analysis and Governance*, Cambridge University Press, Cambridge, 139-150.

Dubock, A. (2019). Golden rice: To combat vitamin A deficiency for public health. *Vitamin A*, 1-21.

Qamar, S., Tantray, A. Y., Bashir, S. S., Zaid, A., & Wani, S. H. (2020). Golden Rice: Genetic Engineering, Promises, Present Status and Future Prospects. In *Rice Research for Quality Improvement: Genomics and Genetic Engineering* (pp. 581-604). Springer, Singapore.

Rahmadi, A., Sari, K., Handayani, F., Yuliani. & Prabowo S. (2019). Modulation of phenolics substances and antioxidant activity in *mandai cempedak* by unsalted spontaneous and *Lactobacillus case* induced fermentation. *Journal Teknologi dan Industri Pangan*. 30(1): 75-82. DOI: 10.6066/j ti p.2019.30.1.75

Rohmah, M., Raharjo, S., Hidayat, C., & Martien, R. (2020). Application of Response Surface Methodology for the Optimization of  $\beta$ -Carotene-Loaded Nanostructured Lipid Carrier from Mixtures of Palm Stearin and Palm Olein. *Journal American Oil Chemical Society* 97-213-223

Rohman, A. (2016). *Lipid: Sifat Fisika-Kimia dan Analisisnya*. Pustaka Pelajar, Yogyakarta.

Tang, G. (2010). Bioconversion of Dietary Provitamin A Carotenoids to Vitamin A in Humans. *Am J Clin Nutr* 91(suppl):1468S-73S.

Zhu, Q., Tan, J., Wang, B., & Liu, Y. G. (2021). Genetic Engineering for Increasing Antioxidant Content in Rice: Recent Progress and Future Perspectives. *Molecular Breeding for Rice Abiotic Stress Tolerance and Nutritional Quality*, 358-381.

## TNP-435

# Green Synthesis of Silver Nanoparticles From Soursop Leaf Extract (*Annona Muricata* Linn.)

Noor Hindryawati<sup>1\*</sup>, Teguh Wirawan<sup>1</sup>, Irfan Ashari Hiyahara<sup>1</sup>, Tiara Partyastuti<sup>1</sup>

Department of Chemistry, Faculty of Mathematic and Natural Sciences, Mulawarman University, Samarinda, East Kalimantan, Indonesia

Corresponding Author\*: hindryawati@gmail.com

## Abstract

Green synthesis of silver nanoparticles using plant has been interested in recent years. In the present study the silver nanoparticles were synthesized using a bioreductor from soursop leaf extract (*Annona Muricata* Linn). In this study, we investigated the concentration of the AgNO<sub>3</sub> solution and then the most stable silver nanoparticles were varied again in the ratio of the volume of the bioreductor to the volume of AgNO<sub>3</sub>. The nanoparticles were characterized using the UV-Vis Spectrophotometer, Particle size analyser (PSA) and Scanning electron microscopy (SEM). The results indicate the most optimum conditions were at a concentration of 1 mM AgNO<sub>3</sub> with a bioreductant volume of 2 times the volume of 1 mM AgNO<sub>3</sub> solution. The results of the SEM analysis show that the particle morphology is spherical and tends to be less uniform. In the PSA analysis results obtained particle size distribution is 40-170 nm and the average is 170.6 nm. This green synthesis provides an economic, eco-friendly, and clean synthesis route to silver nanoparticles.

## Introduction

Currently, there is many researchers develop the innovation on nanotechnology. Nanotechnology is a technique for designing and applying the material with nano structure. One example of nanotechnology that continues to be developed is silver nanoparticles, which is one way to produce silver nanoparticles by chemical synthesis. The chemical reduction method has advantages, among others, the method is easy to do, cheap and can be produced on a large scale. Through this effective method, it is expected to produce stable colloidal nanoparticles so that the nanoparticles do not agglomerate. But the use of the reduction method using chemical reducing compounds to synthesize Ag nanoparticles, can cause by-products in the form of waste that is harmful to the environment. Therefore, a chemical reduction method was carried out using a bioreductant compound or called biosynthesis (Sari et al., 2017). Biosynthetic method or green synthetic to be developed because it uses materials that are safer for the environment.

The bioreductant compounds from plant extracts that will act as reducing agents. The bioreductant will reduce ions Ag<sup>+</sup> into Ag<sup>0</sup> which is known as silver nanoparticles. Plant extracts used as bioreductors are plants that contain antioxidant compounds such as vitamin C and flavonoids (Sari et al., 2017). One of the materials that can be used as a bioreductant is extract of soursop leaves (*Annona Muricata* Linn.), this selection was made because based on the results of research (Adri et al., 2013), soursop leaves contain secondary metabolites in the form of steroids, flavonoids, coumarins, alkaloids, flavonoids and tannins. Some compounds from soursop leaf extract are thought to be used as bioreductants to produce silver nanoparticles.

Based on the description above, in this study focus to synthesize silver nanoparticles using a bioreductant from soursop leaf extract, then the characteristics of the nanoparticles formed can be seen from the characterization

data using a UV-Vis Spectrophotometer and particle size analyzer.

## Methodology

### Equipment and Materials

The materials are AgNO<sub>3</sub>, CH<sub>3</sub>OH, distilled water, soursop leaf (*Annona Muricata* Linn.), PVP, Dragendroff, H<sub>2</sub>SO<sub>4</sub>, Acetic anhydride, HCl, Mg powder, FeCl<sub>3</sub>. The tools used in this research include beaker, volumetric flask, volume pipette, bulb, dropper pipette, hot plate, magnetic stirrer, analytical balance, UV-Vis spectrophotometer, Scanning Electron Microscope, Particle Size Analyzer and rotary evaporator.

### Soursop leaf sample preparation

Soursop leaves are taken as much as 500 grams. Soursop leaves are washed and dry in the air for 14 days, then cut into small pieces with a size of 0.5-1 cm.

### Extraction of Soursop leaf

Soursop leaf extraction via maceration method. 200 grams of soursop leaves were macerated for 7 days using 4 liters of methanol. Then filtered the solution and obtained the filtrate in the form of soursop leaf extract, and the residue in the form of brown leaves. Soursop leaf extract was concentrated using a rotary evaporator. Phytochemical tests were carried out on leaf extracts soursop with a series of tests (alkaloid, flavonoid, phenolic, steroid and saponin)

### Synthesis of Silver nanoparticle

AgNO<sub>3</sub> 1 mM and soursop leaf extract 0.2% (w/w) as bioreductant was added into a beaker glass, according to Table 1, then 0.20 mL of 17% PVP was added. Furthermore, mixed with stirrer for 2 hours at room temperature until the color changed to brown which indicated the nanoparticles had formed. The solution was then characterized using a UV-Vis spectrophotometer to determine its stability.

**Table 1.** Ratio of Bioreductor Volume with AgNO<sub>3</sub> Solution

No.	AgNO <sub>3</sub> :Bioreductant	Bioreductant (mL)	AgNO <sub>3</sub> 1 mM (mL)
1	2:1	20	10
2	1:1	15	15
3	1:2	10	20
4	1:3	10	30

### Stability of Silver Nanoparticles Through Several Analysis of Characterization

The characterization of the formed silver nanoparticles was carried out using a UV-Vis spectrophotometer instrument. Where this characterization aims to determine the formation of silver nanoparticles and their stability. Determination of the maximum wavelength was carried out by measuring the wavelength of the nanoparticle solution formed based on variations in AgNO<sub>3</sub> and composition of the bioreductant of soursop leaf extract. The peaks of colloidal nanoparticles range between 370-650 nm. The absorbance of silver

nanoparticles was measured continuously for 7 days. Furthermore, the most stable silver nanoparticles will be characterized using PSA and SEM. The characterization process aims to determine the particle size distribution and surface morphology information of the synthesized silver nanoparticles are displayed in the form of images.

## Result and Discussion

The synthesise of silver nanoparticles using a bioreductant of soursop leaf extract was carried out by reacting  $\text{AgNO}_3$  with a concentration of 1 mM with a bioreductant of soursop leaf extract with a concentration of 0.2% (W/W) containing flavonoid compounds that can reduce metals (Maryani, *et al.*, 2017). Silver nanoparticles formed can be seen if there has been a color change from the  $\text{AgNO}_3$  solution from clear to brownish yellow. The secondary metabolites of soursop leaves (*Annona Muricata* Linn.) is an alkaloid, triterpenoid, phenolic and flavonoid. Based on the results of the phytochemical test, it can be seen that the Soursop leaves contains flavonoid secondary metabolites. The flavonoids can reduce  $\text{Ag}^+$  because it has a smaller reduction potential compared to  $\text{Ag}^+$ . So that soursop leaves can be used as a bioreductant to make silver nanoparticles.

Silver nanoparticles with various bioreductant volumes and  $\text{AgNO}_3$  volumes were observed for stability of the nanoparticles and the magnitude of the resulting absorbance value was shown in Figure 3 (a) nanoparticles with a volume ratio of 2:1 have a maximum wavelength that is stable at 410 nm from the first day to the seventh day. Then the silver nanoparticles with a 1:1 variation (figure b) has a maximum wavelength of around 410 nm, the silver nanoparticles with 1:2 (figure c) has a maximum wavelength of around 410 nm, then on silver nanoparticles with a variation of 3:1 ( Figure d) obtained a maximum wavelength of 410 nm. From these data it can be seen that all variations in the volume of the bioreductor and the volume of  $\text{AgNO}_3$  do not experience a significant wavelength. Silver nanoparticles with a variation of 1:2 have the largest absorbance value as shown in Figure 3. Based on the research that has been done, it can be seen that the more volume of the bioreductant used, the greater the absorbance value obtained. This is due to the more bioreductors, the more ions.  $\text{Ag}^+$  which is reduced to  $\text{Ag}^0$  ions which causes more silver nanoparticles to be formed (Maryani, *et al.*, 2017).

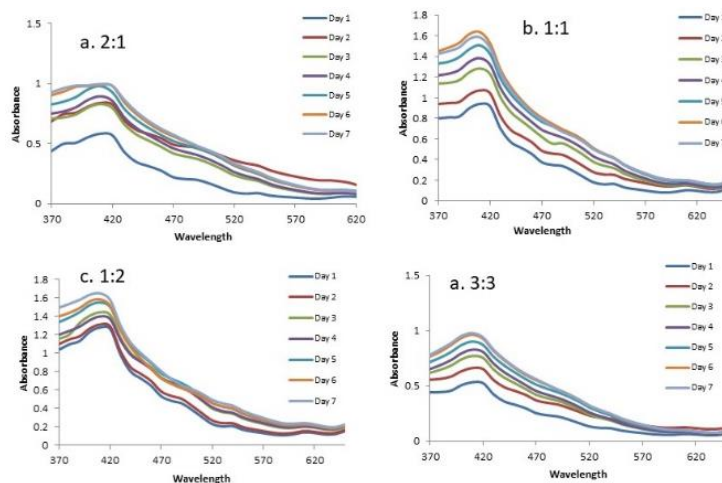

**Figure 3** The results of observations on the stability of silver nanoparticles with bioreductors for 7 days on volume ratio of  $\text{AgNO}_3$  : Bioreductant (a) 2:1 , (b) 1:1, (c) 1:2 and (d) 3:3

The result from the characterization of silver nanoparticles using particle size analyzer (PSA) shown in figure 4.

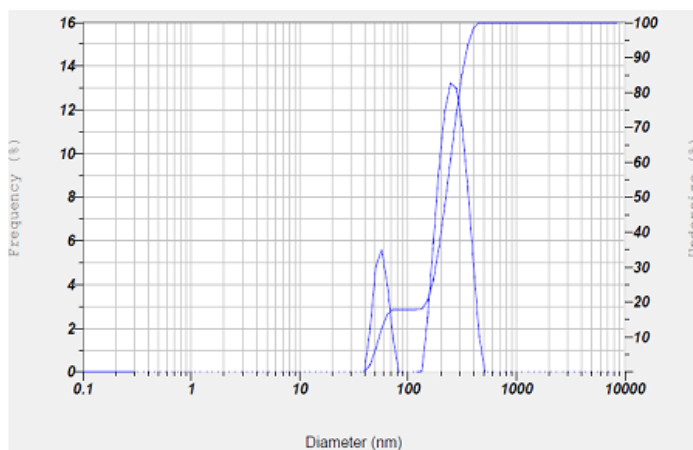

**Figure 4** Particle Size Analyzer (PSA) characterization results on silver nanoparticles

Based on the characterization results in Figure 4, it shows that the silver nanoparticles have sizes ranging from 40-170 nm with an average size of 170.6 nm. The distribution of particles was various due to the effects of agglomeration in nanoparticle during synthesis (Masakke et al., 2014). The surface morphology of silver nanoparticles was shown in figure 5. The morphology of the silver nanoparticles is spherical, tends to be less uniform and agglomerated each other.

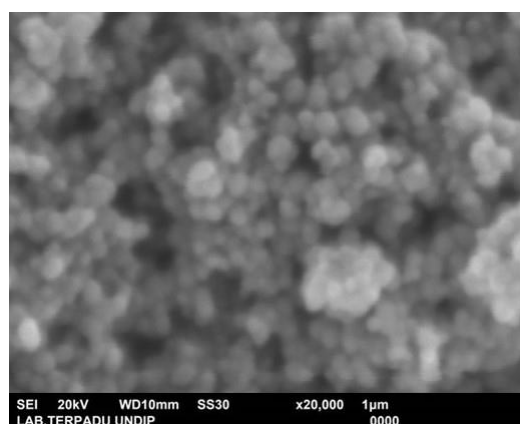

**Figure 5.** The surface morphology of silver nanoparticles using bioreductant from soursop (*Annona muricata* Linn) leaf extract.

## Conclusion

Based on the research that has been done, it is known that silver nanoparticles have been formed using a bioreductant from soursop (*Annona muricata* Linn) leaf extract. The ratio of  $\text{AgNO}_3$  : Bioreductant volume



the 5<sup>th</sup> ICTROPS

International Conference  
for Tropical Studies and Its Applications

Islamic Development Bank 4in1 Project  
Project Implementation Unit  
University of Mulawarman



IsDB  
البنك الإسلامي للتنمية  
Islamic Development Bank



1:2 (w/w) showed the highest stability with AgNO<sub>3</sub> concentration of 1 mM. The surface morphology of silver nanoparticle was spherical and tends to be less uniform with a particle size distribution of 170.6 nm. From this study, the soursop (*Annona muricata* Linn) leaf extract can be one of potential source of bioreductant.

## ACKNOWLEDGEMENT

The authors acknowledge the Mulawarman University for funding the research through IsDB Grant Research 2021 under 405/UN17.11/PL/2021.

## REFERENCES

- Adri, D. dan Hersoelistyorini, W. (2013). Aktivitas Antioksidan dan Sifat Organoleptik Teh Daun Sirsak (*Annona muricata* Linn) Berdasarkan Variasi Lama Pengeringan. *Jurnal Pangan dan Gizi*. 4(7).
- Azhar, F. F. Adibi, S. Anggraini T. dan Sumpono. (2019). Pemanfaatan Nanopartikel Perak Ekstrak Belimbing Wuluh Sebagai Indikator Kolorimetri Logam Merkuri. *Jurnal Iptek Terapan*. 13(1): 34-44.
- Az-Zahra, F. Naspiah, N. Febriana, L. dan Rusli, R. (2020). Sintesis Nanopartikel Perak Menggunakan Ekstrak Metanol Daun Nipah (*Nypa Fruticans*) Sebagai Agen Antibakteri. *Jurnal Sains dan Kesehatan*. Vol 2. No 3.
- Haryani, Y. Ganis F. K. Yuharmen, Eka M. P. Dhia Trubrum dan Yonatha M. (2016). Pemanfaatan Ekstrak Air Rimpang Jahe Merah (*Zingiber officinale* Linn. Var.) pada Biosintesis Sederhana Nanopartikel Perak. *Chimica et Natura Acta* 4(3),Halaman 151-155
- Kudle, K. R. M.R. Donda, R. Merugu, Y. Prashanthi dan M.P.P. Rudra. (2013). Microwave Assisted Green Synthesis of Silver Nanoparticles using Stigmaphyllon Littorale Leaves, Their Characterization and Anti-microbial Activity. *International Journal of Nanomaterials and Biostructures*, 3(1): 13-16
- Maryani, D. Firdaus, M. L. dan Nurhamidah. (2017). Biosintesis Nanopartikel Menggunakan Ekstrak Buah *Passiflora flavicarva* (Markisa) Untuk Mendeteksi Logam Berat. *Jurnal Penelitian dan Pendidikan Kimia*. 1(1): 49-54..
- Masakke, Y., Sulfikar, dan Rasyid, M. (2014). Biosintesis Partikel-nano Perak Menggunakan Ekstrak Metanol Daun Manggis (*Garcinia Mangostana* L). *Jurnal Sainsmat* 4(1) Halaman. 28-41.
- Prasetiowati, A. L., Agung, T.P., dan Sri. W. (2018). Sintesis Nanopartikel Perak dengan Bioreduktor Ekstrak Kulit batang Belimbing Wuluh (*Averrhoa Bilimbi* L.) sebagai Antibakteri. *Indonesia Journal of Chemical Science*, 7(2).
- Sari, P. I., Firdaus, M. L., dan Elvia, R. (2017). Pembuatan Nanopartikel Perak (NPP) dengan Bioreduktor Ekstrak Buah *Muntingia calabura* L Untuk Analisis Logam Merkuri. *Jurnal Pendidikan dan Ilmu Kimia*. 1(1) : 20-26
- Taba, P., Parmitha, N. Y., dan Kasim, S. (2019). Sintesis Nanopartikel Perak Menggunakan Ekstrak Daun Salam (*Syzygium polyanthum*) Sebagai Bioreduktor dan Uji Aktivitasnya Sebagai Antioksidan. *Indo. J. Chem. Res.* 7(1): 51-60.

## TNP-439

# Prototype of Automatic System DC Fan Speed Based by Microcontroller, and Connected to Blynk (Internet of Things)

Muslimin<sup>1</sup>, Nur Rani Alham<sup>2</sup>, Restu Mukti Utomo<sup>3</sup>, Gabriel Sumampouw<sup>4</sup>, Rizki Dwi Saputra<sup>5</sup>, Abdul Mubarak<sup>6</sup>.

Department of Electrical Engineering, Mulawarman University, Indonesia

Corresponding Author\*: [gabriel29th@gmail.com](mailto:gabriel29th@gmail.com)

## Abstract

The fan is always the ordinary thing at home, human needs fan for comfortable while rest, and lower the temperature of the body if the weather is too hot. But fan brings adverse effects like the experience pain in certain parts of the body, for example, Stiffness caused by the strong blow of the wind against the body. The purpose of making this prototype is to automatically adjust the fan speed based on the distance from the fan to the human. By using an ultrasonic sensor, Passive Infrared sensor, we can automatically turn off the fan, without pressing any button. And there is also a DHT11 sensor that allows us to know the room temperature and humidity of the room that is being occupied. The fan will automatically turn off if it does not detect humans within 1 minute 40 seconds. And even though there is no one around, it is still possible to turn it on and off by using the Blynk application, the temperature of the room will also appear on the Blynk application, the microcontroller board used is Arduino Uno, and NodeMCU as an intermediary for the internet

**Keywords:** Automatic Fan, Blynk, NodeMcu, Arduino Uno, IOT

## Introduction

The Automatic Fan DC system uses a DHT11 sensor, Ultrasonic Sensor, and PIR Sensor, based on Arduino Uno and NodeMCU. The purpose of making this prototype is to control the fan speed automatically based on distance from the fan to human using an ultrasonic sensor to read it. Use the PIR (Passive InfraRed) Sensor, we can turn on the fan without press any button, and also there is a DHT11 sensor, which we can know the temperature and humidity of the room. The fan will automatically turn off if the PIR sensor doesn't detect human (motion). In this prototype, we can also turn on/off the fan even if no human in the front of the fan uses the Blynk application on a smartphone. In the Blynk application, we can also see the room temperature and humidity, the fan speed, and the distance between humans and the fan.

What makes the difference in previous research [1],[3] and this research is, the previous use the temperature to control the fan speed, use the LCD 16x2 to show the temperature, in this research use distance to control the fan speed and it is connected to Blynk (Internet of Things) in the smartphone. In the Blynk application, we can see the temperature, humidity, heat index, fan speed, fan state(on/off), distance, and push button to turn on the fan manually.



## Methodology

The research method in this project is to design and create the prototype, testing the result of the designed prototype.

### Literature Study

Before we know how to build a prototype of automatic system DC Fan control speed, we need to know and seek references about the application (ArduinoIDE&Blynk), and the instrument, like Arduino Uno, NodeMCU, Ultrasonic Sensor, DHT11 Sensor, PIR sensor, DC Fan with 4 pins, Relay, Powersupply, Breadboard, and 9 Volt battery.

### Design the concept of Prototype

In this step, we discuss the project and find the background problem of the making this project, which one many people have some stitch because the strong wind breeze from the fan, and the variable is the distance. In this project, the wind flow will more strong if the distance between humans and the fan is far away, and the wind flow is slower if the distance between humans and the fan is closer. The work system can be seen in Figure 1 below.

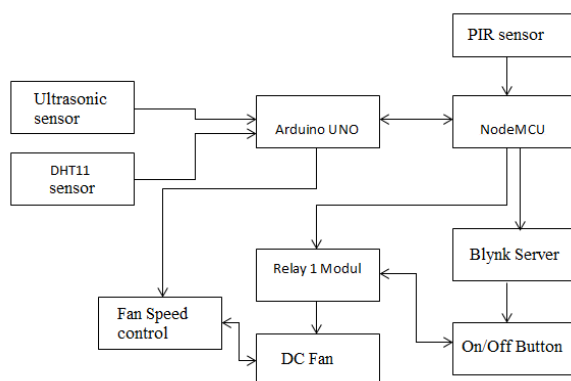

**Figure 3.** The Work System Of The Prototype

The detail about the quantity of the used components is shown in Table 1 below.

**Table 1. The Used Components Table**

Component Name	Quantity
Arduino Uno	1
NodeMCU	1
DHT11 Sensor	1
Ultrasonic Sensor	1
Passive Infra-Red Sensor	1
Relay	1

Power Supply 12 Volt	1
<b>Component Name</b>	<b>Quantity</b>
Battery 9 Volt	1
Jumper Wire	25
DC Fan 12 Volt	1
Breadboard	2

### Sensor testing

The purpose of testing the sensor in this project is to ensure the sensor will be used in good condition and can be used. The tested sensor is the Ultrasonic sensor, DHT11 sensor, PIR sensor.

### Create the Blynk Interface

We need to create the Blynk Interface using the tools like digital LCD and push button on the Blynk. Blynk application informs the temperature, heat index, humidity, distance, fan speed, the condition of the fan (on/off), and the button to turn on the fan if the user wants to turn on the fan tough nobody in the front of the fan.

### Assembly and merging the code

After making sure all of the used components are in good condition, we assembly each of the components, and merging the code, and build an algorithm for the willing concept to come true. The schematic of the system is shown in Figure 2

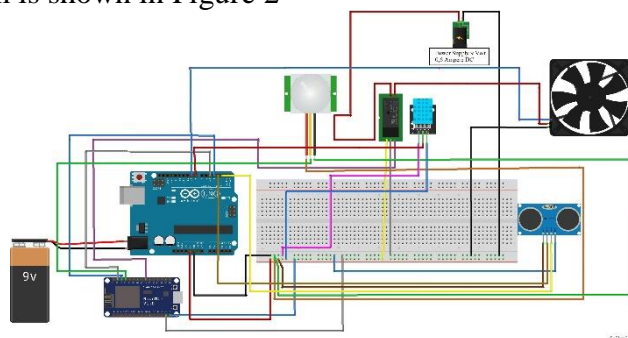

**Figure 2.** The Schematic of The System

### Final Testing

We do the test where all of the code and the component is installed. After this project can run as desired, this project is declared complete, if the project can not run as desired, we fix and analyze the problem and try again to run it again.

## Results and Discussion

The result of this project is shown below

### Hardware realization

The system has been assembled. The physical form in this system is shown in Figure 3 below.

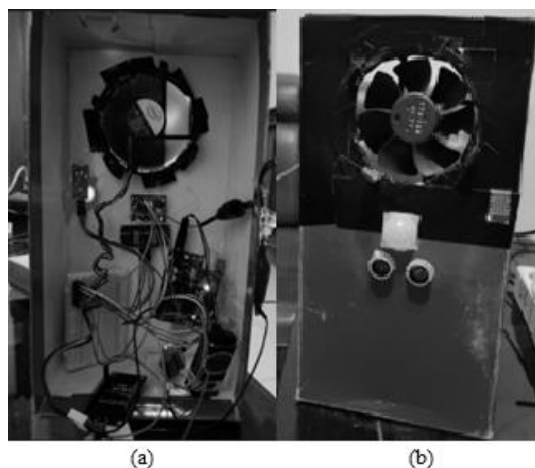

**Figure 3.** The Physical Form of the Prototype. (a).Backside, (b).Frontside.

#### Testing DHT 11 sensor

The result of testing DHT11 is the heat index ( $^{\circ}\text{C}$ ), the temperature ( $^{\circ}\text{C}$ ), and humidity (%) are shown in Figure 4, Figure 5, and Figure 6 below.

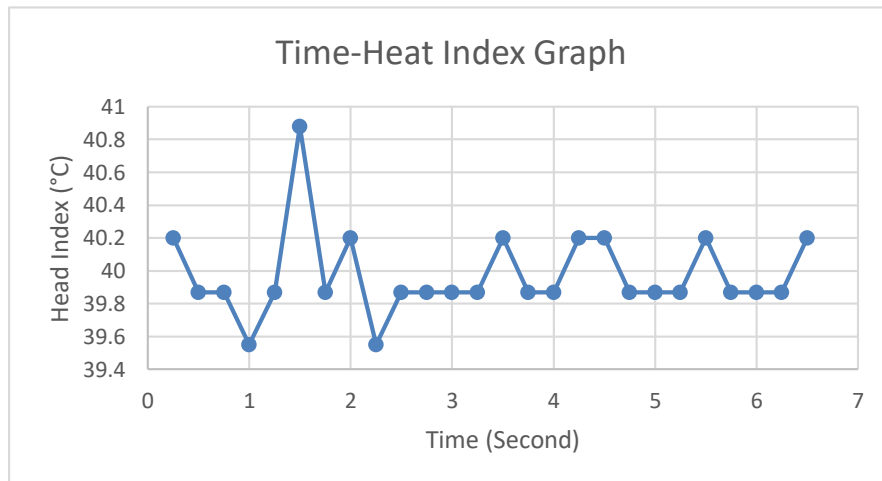

**Figure 4.** Time-Heat Index Graph

As you can see in figure 5, the heat index changes around  $40.88^{\circ}\text{C}$  –  $39.55^{\circ}\text{C}$ , so the DHT11 sensor has good precision. You can compare the heat index (Figure 4) with the temperature (Figure 5) measurement.

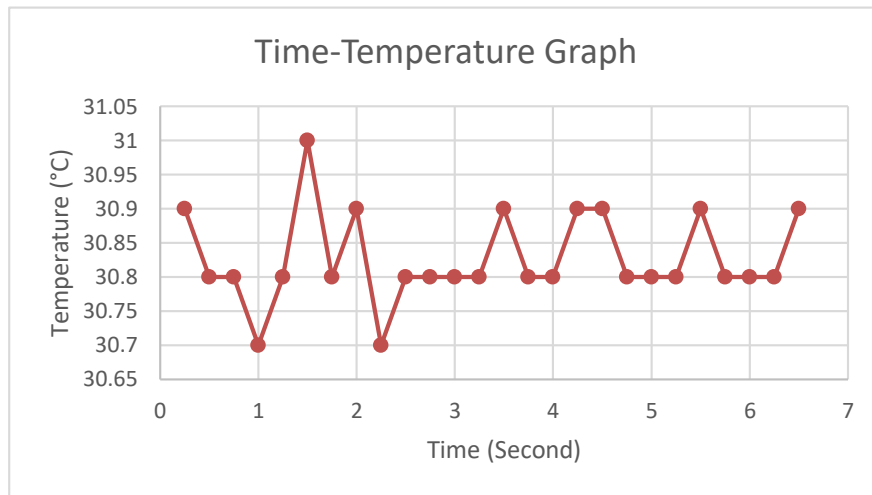

**Figure 5.** Time-Temperature Index Graph

As you can see in figure 5, the temperature changes around 31 °C – 30.7°C, so the DHT11 sensor has good precision. If you compare Figure 4 with the Figure 5 graph, the heat index and temperature is correlate.

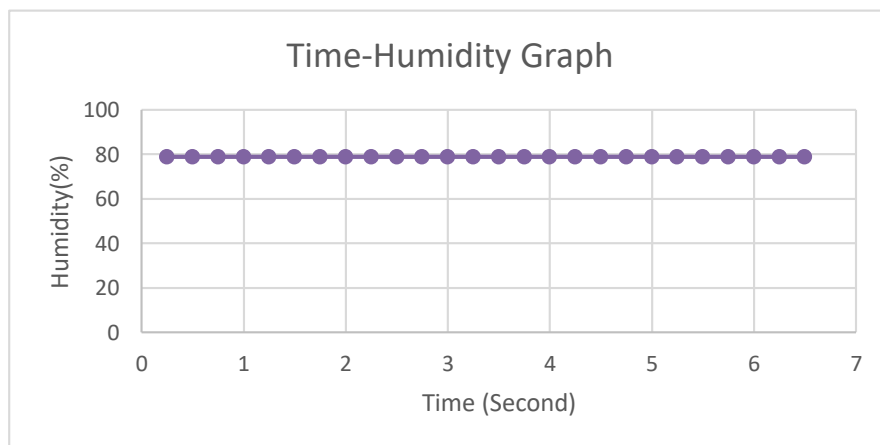

**Figure 6.** Time-Humidity Graph

In Figure 6 the humidity in the room is stable at 80%.

Testing Ultrasonic sensor

The result of testing the Ultrasonic sensor is distance, and the fan speed will change, the range of distance for the fan speed is shown in Table 2 below.

**Table 2.** Distance - Fan Speed Table

Distance (cm)	Fan Speed
<10	20%
10-15	25%
15-25	50%
25-35	75%
>35	100%

### Testing PIR sensor

The result of the testing PIR sensor is you know there is a human on the front of the sensor, then the relay will switch to turn on the fan, it does not detect humans the relay will turn off the fan. The correlation between PIR detection, relay, and fan condition is shown in Table 3 below.

**Table 3.** Passive Infra-Red, Relay, and Fan Condition Table

PIR Detect Human Motion	Relay	Fan
No	Switch to Off	Off
Yes	Switch to On	On

### Software realization

The way to software realization in this system is to program the Arduino Uno and NodeMCU board. The given program is to read the input from the Ultrasonic sensor, DHT11 sensor, PIR sensor. We also program NodeMCU for the input from the sensor can be seen on smartphones use the Blynk Application.

The software is succeeding to realized, the fan can turn on/off automatically if the PIR sensor read the human motion or not, we can see the temperature, humidity, and heat index use DHT11 sensor, the fan speed can be adjusted automatically use the distance that input by Ultrasonic sensor.

The fan will automatically turn off if not detect human motion in 1 minute and 40 seconds, if you use the push button on the Blynk application, the fan will turn on last for 7 seconds, if the PIR sensor did not detect any motion, the fan will also turn off. The displayed data on Blynk is shown in Table 4.

**Table 4.** Blynk Displayed Data

Name	Value
Temperature	29°C
Heat Index	37°C
Humidity	84%
Distance	70 CM
Fan	ON
Speed	100%



## Conclusions

DHT 11 sensor can be used to read the temperature, humidity, and heat index inside the room. An ultrasonic sensor can be used to read the distance between the fan and human, this distance is used to control the fan speed. PIR sensor can be used to read is somebody in front of the fan or not, it uses to control the relay which is the relay that will cut or connect the electric current power of the fan. Blynk application can be used to show the data like temperature, humidity, heat index, the fan speed, state of the fan(on/off), and the distance.

## TNP-442

# Potential of Nutraceutical Gummy Candy from Kepok Banana Peel Extract (*Musa paradisiaca* Linn.) in Combination with Kelulut Honey (*Trigona incisa*) as a Covid-19 Supportive Therapy

Yurika Sastyarina<sup>1\*</sup>, Nabila Nayif Nur Akmalia<sup>1</sup>, Rohani<sup>1</sup>, Alya Fajrina Soraya<sup>1</sup>

<sup>1</sup>Faculty of Pharmacy, Mulawarman University

\*Corresponding author: yurika@farmasi.unmul.ac.id

### Abstract

Mutation of Coronavirus Disease causes the need to implement health protocols, in line with the ongoing research on Covid-19 treatment. In patients with Covid-19, oxidative stress can occur due to the production of free radicals resulting from the high activity of pro-inflammatory cytokines. Flavonoids and their derivatives have three mechanisms in Covid-19: an antioxidant to prevent oxidative stress, a cofactor of endogenous antioxidant, and binding specifically to Sars-CoV-2 protein. The content of flavonoid compounds in kepok banana peels and kelulut honey can be used as antioxidants to prevent oxidative stress, made in nutraceutical gummy candy because it is attractive and widely liked. The purpose of this research is to determine the antioxidant activity of the combination of kepok banana peel extract and kelulut honey, the optimal formula for gummy candy base, the excellent formula for gummy candy preparations from kepok banana peel extract and kelulut honey, and its potential as supportive therapy for Covid-19 through its antioxidant activity. This research is empirical research and laboratory research. The proper gummy candy formula was optimized using Design Expert V.10 software. Antioxidant activity of the combination increasing the antioxidant activity of each with an IC50 value of 83.176 ppm at V2. The best optimization base formula is F2, with a ratio of gelatin and carrageenan 0.588% and 0.412%. The antioxidant activity in the gummy candy formulation has an IC50 value of 93.34 ppm. The evaluation, such as organoleptic, moisture content, ash content, and heavy metal contamination, is compatible with the requirements in SNI-3547.2-2008 about gummy candy. Based on the results, it can be seen that the nutraceutical gummy candy made has the potential as a supporting therapy for Covid-19.

**Keywords:** Covid-19, Gummy Candy, Antioxidant, *M. paradisiaca*, *Trigona incisa*

### Introduction

Coronavirus Disease (Covid-19) is a global problem with SARS-CoV-2 as the virus. In patients with Covid-19, oxidative stress can occur due to increased free radicals from the high levels of pro-inflammatory cytokines, which also reduce endogenous antioxidants (Wu, 2020). It causes the need for antioxidants and comprehensive management, such as increasing the need for vitamins and minerals with micronutrients (Muhammad et al., 2021). Micronutrients are recommended through nutraceutical administration (PDGKI, 2020). Nutraceutical is food or part of food that is beneficial for health, prevention, and treatment. The use of nutraceuticals in supporting Covid-19 therapy plays a role in increasing the immune system by utilizing antioxidant substances (Puertollano et al., 2011).



the 5<sup>th</sup> ICTROPS

International Conference  
for Tropical Studies and Its Applications

Islamic Development Bank 4in1 Project  
Project Implementation Unit  
University of Mulawarman



IsDB  
البنك الإسلامي للتنمية  
Islamic Development Bank



Flavonoid compounds and their derivatives have been studied to have antioxidant bioactivity. The compound targeting Mpro, a structural protein of SARS-CoV-2, has the potential as a Covid-19 drug. Based on in silico studies, quercetin, apigenin, and catechins showed antiviral potential with good binding affinity to Mpro. Furthermore, quercetin also showed good binding affinity to Transmembrane Serine Protease 2, a surface protein of SARS-CoV-2. Kaempferol and chrysin showed an excellent binding affinity and inhibited the interaction between ACE-2 and S-Protein SARS-CoV-2 (Alzaabi et al., 2021).

Banana peel waste can be increased its functional value to become nutraceutical because bananas are abundant and accompanied by a lack of waste utilization. In fact, there are 34,629 kg per year of kepok banana peel waste in East Kalimantan (BPS, 2019). In addition, banana peels contain essential elements such as magnesium, phosphorus, iron, and sodium (Aboul-Enein et al., 2016). Kepok banana peel extract (KE) has moderate antioxidant activity with an Inhibition Concentration (IC<sub>50</sub>) of 128.46ppm (Ulfa et al., 2020). KE toxicity is classified as safe with a lethal dose (LD<sub>50</sub>) in rats of 5 g/kg or 302.5 g/kg in humans (Ugbogu et al., 2018).

Kelulut honey (KH) is produced from the stingless bee species *Trigona incisa*. This honey has a strong antioxidant IC<sub>50</sub> of 97ppm (Gunawan, 2018). Antioxidants of KH are due to its flavonoids, namely gallic acid, syringic acid, apigenin, chrysin, cinnamic acid, kaempferol, and rutin (Zawawi et al., 2021). They contain mineral elements such as potassium, sodium, calcium, magnesium, iron, and zinc (Moniruzzaman et al., 2014). Flavonoids in KE and KH can be used as antioxidants. In addition, the existing mineral content is indispensable as a cofactor for endogenous antioxidant enzymes (Muhammad et al., 2021) et al., 2021). The combination was chosen because the two ingredients have different antioxidant mechanisms, so that they are synergistic. It is then selected nutraceutical preparations that are reliable and attractive options for disease prevention or treatment because they are cost-effective and have high nutritional rates (Golla, 2018). The nutraceutical was chosen in gummy candy with the advantages of having an attractive color, smell, taste, shape, and a high level of acceptance (Juliantoni et al., 2018). Thus, research and a nutraceutical formulation of gummy candy were carried out as a supporting therapy for Covid-19 through antioxidant activity tested by the 2,2-diphenyl-1-picrylhydrazyl (DPPH) method.

## Methodology

### Collection, Determination, and Extraction

The kepok banana peel waste was obtained from a local seller and determined at the Dendrology and Forestry Ecology Laboratory, Mulawarman University, and kelulut honey was obtained from local farmers in Buana Jaya Village. The extraction steps started with kepok banana peels, washed, and then sorted. The inner banana peel is dried in a 40°C oven. It was powdered and then macerated with 70% ethanol for 3x24 hours then concentrated with a 50°C rotary evaporator. Then the yield was calculated. After obtaining the extract, the ethanol solvent-free test was carried out. A total of 2 drops of concentrated sulfuric acid and 1 mL of 2% potassium dichromate were added to the extract. The color change from orange to bluish green indicated that the extract was not ethanol-free.

### Active Compounds Optimization

The active compounds concentration is determined by comparing three formulas tested for antioxidant activity. The aim is to obtain the optimal formula with the highest antioxidant activity. There are three formula



variations: V1 contains 250 mg KE and 250 mg KH, V2 contains 100 mg KE and 400 mg KH, then V3 contains 400 mg KE and 100 mg KH.

The procedure was in the form of 2 mg DPPH dissolved in 50 mL of ethanol pro-analysis (pa) and incubated in a dark room for 30 minutes. Each comparison of KE:KH variation was dissolved with 100 mL pa ethanol. Series solutions with concentrations of 200, 400, 600, 800, and 1000 ppm were made. The concentration series of 2 mL was added with 2 mL of DPPH, incubated in a dark room for 30 minutes, and then the absorbance was measured at 517 nm. The data obtained in the form of absorbance for each formula comparison, the percentage of inhibition against DPPH radicals was calculated with the formula:

$$\% \text{ Inhibition} = \frac{(\text{Blank absorbance} - \text{sample absorbance})}{\text{Blank absorbance}} \times 100\% \quad (1)$$

The IC<sub>50</sub> value was determined by linear regression of the concentration log value (x-axis) against the probit of percent inhibition value (y-axis). The equation is  $y = bx + a$ , where the y variable is 5, and the antilog x is IC<sub>50</sub>.

### Gummy Candy Base Optimization

Two independent variables, gelatin, and carrageenan were selected to be optimized using the Simplex Lattice Design (SLD) method on Design-Expert software with a response were water content. The predicted optimal concentration of the mixture and the correspondence with the response were verified by conducting experiments at the concentrations of the specified variables (Čižauskaitė et al., 2019). The results are then entered into the software to determine the optimum concentration according to the desired response automatically.

### Gummy Candy Formulation

Each formula for the ratio of gelatin: carrageenan was dissolved in water and stirred while heated to 80°C, then added sodium propionate, sorbitol, and banana flavor. Wait for the dough to cool, then add the ethanol extract of the kepok banana peel and kelulut honey, stir until homogeneous. The dough that has been mixed evenly is poured into the mold and cooled.

**Table 3.** Gummy candy formula

Material	Amount	Material	Amount
Kepok banana peel ethanol extract	1%	Sorbitol	5%
Kelulut honey	4%	Sodium propionate	0,32%
Gelatin	12%	Banana flavoring	3 drops
Carrageenan	4%	Aquadest	Ad 250 mL

### Physical Evaluation (Indonesian National Standards 3547.2-2008) and Qualitative Assay of Heavy Metals Contamination

Physical evaluation conducted in three assays, such as organoleptic and Organoleptic assessment, observed gummy candy's color, shape, aroma, taste, and texture. The water content was measured with moisture balance at temperature 105°C for a maximum of 30 minutes with three replications. For the ash content, the crucible is pre-heated and then cooled in a desiccator. Add 2 g of gummy candy with three replications. The crucible containing the sample was put into the kiln and ashed at 600°C for ±3 hours. The ash obtained was weighed

and calculated by dividing the weight of ash with the sample then multiplied by 100%. After assessing physical evaluation, then qualitative assay of heavy metals contamination was in the form of testing for the presence of lead by adding dilute hydrochloric acid (HCl). Then mercury and copper are added with dilute potassium iodide (KI).

### Measurement of Gummy Candy Antioxidant Activity

500 mg gummy candy was dissolved with ethanol (pa) in a 100 mL volumetric flask. Centrifuged at 3000 rpm for 10 minutes. Series concentrations of 200, 400, 600, 800, and 1000 ppm were made. 2 mL concentration series solution was taken and put into a test tube, added with DPPH solution (1:1), and incubated in the dark for 30 minutes. The absorbance was measured at a wavelength of 517 nm.

### Data Analysis

The antioxidant activity was analyzed by linear regression using Microsoft Excel software to get the IC<sub>50</sub> value. The IC<sub>50</sub> value of each formula was seen in comparison using a bar chart. The optimization of gelatin and carrageenan component base with water content response was analyzed using the Simplex Lattice Design method on the Design-Expert software. Data analysis of the final preparation of gummy candy with a combination of kepok banana peel extract and kelulut honey such as organoleptic evaluation, moisture content, ash content, and heavy metal contamination was observed for compliance with the SNI 35347.2-2008 standard.

## Results and Discussion

### Collection, Determination, and Extraction

The determination results showed that the sample used was a kepok banana (*Musa paradisiaca* Linn.) of the Musaceae family, and based on the type of bee that produced kelulut honey, it was a stingless bee (*Trigona* sp) of the Apidae family. Maceration of kepok banana peel (257 g) with 70% ethanol produced an extract of 249 g with a yield of 96.88%. The solvent-free test did not show a bluish-green color indicating the solvent-free extract.

The extraction method using maceration was chosen because it is easy to do, the equipment is simple, does not use heat, and does not disturb the stability of the secondary metabolites of the kepok banana peel. The solvent used is 70% ethanol because the extraction has a higher antioxidant activity than 96% ethanol or water (Ulfa et al., 2020). Because 70% ethanol still contains 30% water, a polar solvent, secondary metabolites are attracted to ethanol and water. Phytochemical compounds with antioxidant activity such as phenols, flavonoids, and tannins are soluble in polar solvents. Therefore, the withdrawal of these compounds is maximized using 70% ethanol solvent (Melodita, 2011).

### Active Compounds Optimization

The active compounds were optimized to compare the concentration of KE and KH, which had the highest antioxidant activity. An antioxidant test was carried out using the DPPH method. The comparison of IC<sub>50</sub> values V1, V2, and V3 is presented in the diagram.

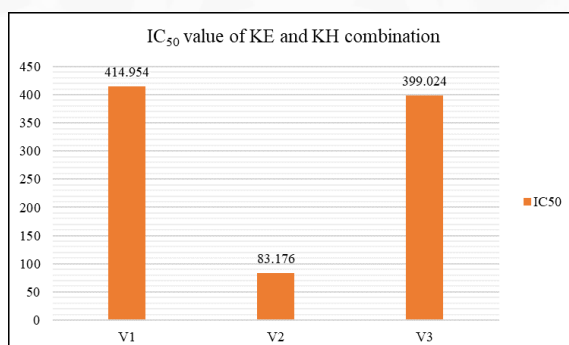

**Figure 4.** Comparison diagram of antioxidant activity between each variant

V2 Antioxidant activity with the ratio of KE and KH 100:400 is the highest compared to V1 and V3 with an IC<sub>50</sub> value of 83.176 ppm. This value is included in the category of strong antioxidants, namely 50-100 ppm.

**Table 4.** Antioxidant activity of KE and KH combination

Variation	Linear Regression Equation	IC <sub>50</sub> (ppm)
V1	$y = 0.672x + 3.2409$ ; $R^2=0.9278$	414.954
V2	$y = 1.2064x + 2.684$ ; $R^2 = 0.9483$	83.176
V3	$y = 0.8322x + 2.8351$ ; $R^2= 0.9203$	399.024

Kepok banana peel contains flavonoid phytochemical compounds that play an essential role as antioxidants, including chrysin 460.24 mg/kg, quercetin 78.62 mg/kg, catechins 30.21 mg/kg, cinnamic acid 8.14 mg /kg, coumarin 0.79 mg/kg (Aboul-Enein et al., 2016). The antioxidant activity of kelulut honey is associated with the content of flavonoid phytochemical compounds it contains, namely gallic acid, syringic acid, apigenin, chrysin, cinnamic acid, hydroxycinnamic acid, kaempferol, and quercetin-3-O-glycoside (rutin) (Zawawi et al., 2021).

### Basis Optimization

Gummy candy basis optimization was carried out on two materials, namely gelatin and carrageenan. Gelatin as a gelling agent works by changing the liquid into a solid to be elastic, improving the shape and texture of the resulting gummy candy. Combined with carrageenan, a gelling agent and plasticizer to produce optimum and not brittle gummy candy (Andasari et al., 2019). The optimization results carried out on the application showed that the ratio between gelatin and carrageenan was 0:1; 0.75:0.25; 0.25:0.75; 1:1; and 1:0.

The recommendations are then converted and calculated so that the following formula variations are obtained:

**Table 5.** Variation formulas for basis optimization

Material	Fy	F1	F2	F3	Fx
Kepok banana peel ethanol extract	2.5 g	2.5 g	2.5 g	2.5 g	2.5 g
Kelulut honey	10 g	10 g	10 g	10 g	10 g
Gelatin	0 g	22.5 g	7.5 g	15 g	30 g
Carageenan	10 g	2.5 g	7.5 g	5 g	0 g

Sorbitol	12.5 g	12.5 g	12.5 g	12.5 g	12.5 g
Sodium propionate	0.8 g	0.8 g	0.8 g	0.8 g	0.8 g
Banana flavoring	3 drops	3 drops	3 drops	3 drops	3 drops
Aquadest	214 mL	199m L	209 mL	204 mL	194mL

The optimization parameter carried out is in the form of water content in percent units. The results of the water content of Fy were 33.7%, F1 10.4%, F2 15.9%, F3 19.26%, and Fx 6.79%. Moreover, obtained the SLD equation as follows:

$$Y = 33,7(A) + 6,79(B) - 17,74(A)(B) \quad (2)$$

The SLD equation obtained means that the proportion of carrageenan (A) can increase the water content more strongly than gelatin (B) or a mixture of carrageenan and gelatin (AB) because it has a coefficient value more significant than gelatin and is positive.

The water content obtained from the five concentration variations, there is one that does not comply with the requirements of SNI 3547.2-2008 because it exceeds 20%, namely the Fy formula, which contains a carrageenan base without gelatin. The increase in water content along with the increase in the amount of carrageenan can be seen in the graph of the following SLD analysis results:

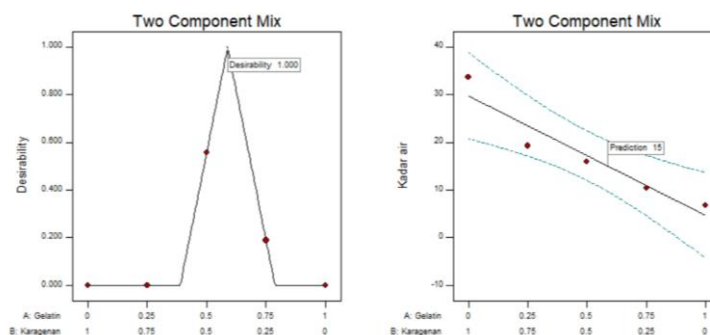

**Figure 5.** Graph of the correlation between water content with the concentration of gelatin and carrageenan

The results were then re-analyzed using SLD to get the right combination of concentrations between gelatin and carrageenan according to the water content requirements. The target moisture content used was 15%, so that the concentrations of gelatin and carrageenan were 0.588% and 0.412%. The graph profile of the counterplot obtained the optimum formula with 0.588% gelatin concentration and 0.412% carrageenan with desirability 1. The optimum water content of the predicted formula was 15%, while the experimental result was 14.67%. It is shown that the optimum water content value obtained has been fulfilled.

Besides looking at the water content, optimizing this basis is also seen from an organoleptic evaluation. Fy, a formula with 10 g carrageenan and without gelatin, has a more rigid texture, while Fx with 12.5 g gelatin and without carrageenan has the opposite characteristic, which is softer and even melts after 12 hours. It is due to the higher water-binding capacity of the carrageenan polymer matrix than gelatin because carrageenan

interacts with water through hydrogen and ionic bonds (Tako et al., 2014). In contrast, gelatin interacts through hydrogen bonds and van der Waals interactions (Van Vlierberghe et al., 2014). They are composed of hydrophobic amino acids, namely 21% glycine, 12% proline, and 9% alanine, causing the water-binding capacity of gelatin to be lower than that of carrageenan (Kariduraganavar et al., 2014). The higher water binding capacity and the double-helical interaction on the carrageenan polymer matrix cause the resulting gel texture to be stiffer and less brittle.

### Evaluation

The organoleptic evaluation results of the final preparation of gummy candy combined with banana peel extract and kelulut honey included a clear golden yellow color, flower shape, banana aroma, and typical kelulut honey, sweet taste with a bit of sour from kelulut honey, chewy texture. The organoleptic characteristics observed are included in the normal category according to the requirements of SNI-3547.2-2008.



**Figure 6.** Gummy candy from kepok banana peel extract and kelulut honey

The water content was measured to determine the water content bound by the gummy candy preparation material. The water content determines the texture, appearance of the preparation, and resistance to microorganism contamination so that it greatly affects the quality of the preparation (Herawati, 2008). The moisture content is shown in table 6. The results of measuring the water content of the final preparation of gummy candy combination of kepok banana peel extract and kelulut honey were  $14.67\% \pm 0.023$ . These results meet the requirements of SNI-3547.2-2008, where the water content of the jelly candy is said to be good and fulfills the requirements if it is  $\leq 20\%$ .

The ash content is related to the mineral content of gummy candy, but the ash content of the food must meet the established standards because it is related to purity and contamination. The ash content is shown in table 6. The measuring result of the ash content of the final preparation of gummy candy with a combination of ethanol extract and kelulut honey was  $1.572\% \pm 0.1110$ . These results meet the requirements of SNI-3547.2-2008, where the maximum ash content of jelly candy allowed is 3%. Ash content is also related to mineral content. Kepok banana peel extract is known to contain macronutrients such as potassium, calcium, sodium, phosphorus, magnesium, and micronutrients like iron, zinc, and manganese (Aboul-Enein et al., 2016). Simultaneously, kelulut honey contains macronutrients potassium, sodium, calcium, magnesium, and micronutrients like iron and zinc (Moniruzzaman et al., 2014).

**Table 6.** The evaluation result of water and ash content evaluation of gummy candy

Assay Parameter	Result	SNI-3547.2-2008
Water content	$14.67\% \pm 0.023$	$\leq 20\%$
Ash content	$1.572\% \pm 0.111$	$\leq 3\%$

Qualitative analysis of the presence of heavy metals in gummy candy results are presented in the following table:

**Table 7.** Qualitative assay result of heavy metal in gummy candy

Metal Cation	Reagent	Observation	Result
Pb <sup>2+</sup>	HCl 1 N	White sediment	No sediment observed
Hg <sup>2+</sup>	KI 20%	Red sediment	No sediment observed
Cu <sup>2+</sup>	KI 20%	White sediment	No sediment observed

### Antioxidant Activity

The results of the antioxidant activity test by DPPH method for the final preparation of gummy candy showed an IC<sub>50</sub> value of 93.34 ppm, where the value was more significant than the IC<sub>50</sub> value of the combination of kepok banana peel extract and kelulut honey before being formulated into gummy candy preparations, which was 83,176 ppm. However, the antioxidant activity of the final preparation was still included in the category of strong antioxidants, namely 50-100 ppm. It is shown that KE and KH flavonoid compounds can be well formulated into gummy candy bases.

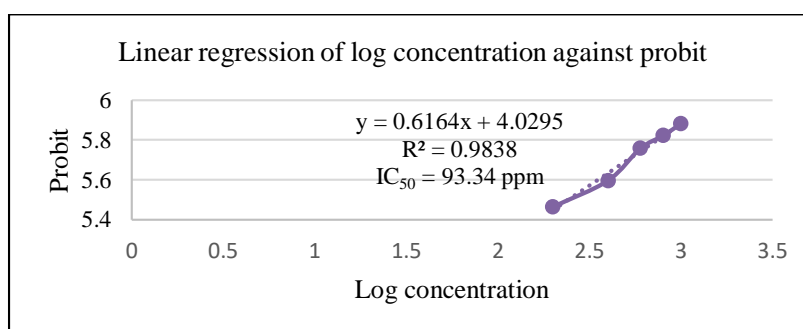

**Figure 7.** Antioxidant activity of gummy candy

### Conclusions

The combination of kepok banana peel extract with kelulut honey increased antioxidant activity compared to without the combination with an IC<sub>50</sub> value of 83.176 ppm at various concentrations of V2. The best optimization of the gummy candy formula base is F2, in which gelatin concentration is higher than carrageenan. The final product of nutraceutical gummy candy has an antioxidant activity of 93.34 ppm. The organoleptic, moisture content, ash content, and heavy metal contamination evaluation are in accordance with the requirements set out in SNI-3547.2-2008. The results obtained indicate that the nutraceutical gummy candy can be a supporting therapy for Covid-19.

### ACKNOWLEDGMENT

The authors are thankful to the Directorate General of Higher Education Ministry of Education and Culture



the 5<sup>th</sup> ICTROPS

International Conference  
for Tropical Studies and Its Applications

Islamic Development Bank 4in1 Project  
Project Implementation Unit  
University of Mulawarman



IsDB  
البنك الإسلامي للتنمية  
Islamic Development Bank



Republic of Indonesia for funding research through the Student Creativity Program (PKM) in 2021.

## REFERENCES

- A Puertollano, M., Puertollano, E., Alvarez de Cienfuegos, G., & A de Pablo, M. (2011). Dietary antioxidants: immunity and host defense. *Current Topics in Medicinal Chemistry*, 11(14), 1752–1766.
- Aboul-Enein, A. M., Salama, Z. A., Gaafar, A. A., Aly, H. F., Abou-Elella, F., & Ahmed, H. A. (2016). Identification of phenolic compounds from banana peel (*Musa paradaisica* L.) as antioxidant and antimicrobial agents. *Journal of Chemical and Pharmaceutical Research*, 8(4), 46–55.
- Alzaabi, M. M., Hamdy, R., Ashmawy, N. S., Hamoda, A. M., Alkhatay, F., Khademi, N. N., Al Joud, S. M. A., El-Keblawy, A. A., & Soliman, S. S. M. (2021). Flavonoids are promising safe therapy against COVID-19. *Phytochemistry Reviews*, 1–22.
- Andasari, S. D., Zukhri, S., & Nurjanah, P. (2019). FORMULASI PERMEN JELLY BUNGA TURI (*Sesbania grandiflora*. L) DENGAN VARIASI KADAR GELATIN DAN KARAGENAN. *CERATA Jurnal Ilmu Farmasi*, 9(1).
- Čižauskaitė, U., Jakubaitytė, G., Žitkevičius, V., & Kasparavičienė, G. (2019). Natural ingredients-based gummy bear composition designed according to texture analysis and sensory evaluation in vivo. *Molecules*, 24(7), 1442.
- Golla, U. (2018). Emergence of nutraceuticals as the alternative medications for pharmaceuticals. *Int J Complement Alt Med*, 11(3), 155–158.
- Gunawan, R. (2018). Uji Fitokimia dan Penentuan Aktivitas Antioksidan dari Madu *Trigona incisa*. *Jurnal Atomik*, 3(1), 18–21.
- Herawati, H. (2008). Penentuan umur simpan pada produk pangan. *Jurnal Litbang Pertanian*, 27(4), 124–130.
- Juliantoni, Y., Wirasisya, D. G., & Hasina, R. (2018). Formulasi Nutrasetikal Sediaan Gummy Candies Sari Buah Duwet (*Syzygium cumini*). *Jurnal Kedokteran*, 7(2), 9.
- Kariduraganavar, M. Y., Kittur, A. A., & Kamble, R. R. (2014). *Chapter 1 - Polymer Synthesis and Processing* (S. G. Kumbar, C. T. Laurencin, & M. B. T.-N. and S. B. P. Deng (eds.); pp. 1–31). Elsevier. <https://doi.org/https://doi.org/10.1016/B978-0-12-396983-5.00001-6>
- Melodita, R. (2011). *Identifikasi pendahuluan senyawa fitokimia dan uji aktivitas antioksidan ekstrak daun cincau hitam (Mesona palustris bl.) dengan perlakuan jenis pelarut*. Universitas Brawijaya.
- Moniruzzaman, M., Chowdhury, M. A. Z., Rahman, M. A., Sulaiman, S. A., & Gan, S. H. (2014). Determination of mineral, trace element, and pesticide levels in honey samples originating from different regions of Malaysia compared to Manuka honey. *BioMed Research International*, 2014.
- Muhammad, Y., Kani, Y. A., Iliya, S., Muhammad, J. B., Binji, A., El-Fulaty Ahmad, A., Kabir, M. B., Umar Bindawa, K., & Ahmed, A. (2021). Deficiency of antioxidants and increased oxidative stress in COVID-19 patients: A cross-sectional comparative study in Jigawa, Northwestern Nigeria. *SAGE Open Medicine*, 9, 2050312121991246.



the 5<sup>th</sup> ICTROPS

International Conference  
for Tropical Studies and Its Applications

Islamic Development Bank 4in1 Project  
Project Implementation Unit  
University of Mulawarman



IsDB  
البنك الإسلامي للتنمية  
Islamic Development Bank



Tako, M., Tamaki, Y., Teruya, T., & Takeda, Y. (2014). The principles of starch gelatinization and retrogradation. *Food and Nutrition Sciences*, 2014.

Ugbogu, E. A., Ude, V. C., Elekwa, I., Arunsi, U. O., Uche-Ikonne, C., & Nwakanma, C. (2018). Toxicological profile of the aqueous-fermented extract of *Musa paradisiaca* in rats. *Avicenna Journal of Phytomedicine*, 8(6), 478.

Ulfa, A., Ekastuti, D. R., & Wresdiyati, T. (2020). Potensi Ekstrak Kulit Pisang Kepok (*Musa paradisiaca* forma typica) dan Uli (*Musa paradisiaca sapientum*) Menaikkan Aktivitas Superoksida Dismutase dan Menurunkan Kadar Malondialdehid Organ Hati Tikus Model Hiperkolesterolemia. *Acta VETERINARIA Indonesiana*, 8(1), 40–46.

Van Vlierberghe, S., Graulus, G.-J., Samal, S. K., Van Nieuwenhove, I., & Dubruel, P. (2014). Porous hydrogel biomedical foam scaffolds for tissue repair. In *Biomedical foams for tissue engineering applications* (pp. 335–390). Elsevier.

Wu, J. (2020). Tackle the free radicals damage in COVID-19. *Nitric Oxide*, 102, 39–41.

Zawawi, N., Chong, P. J., Mohd Tom, N. N., Saiful Anuar, N. S., Mohammad, S. M., Ismail, N., & Jusoh, A. Z. (2021). Establishing Relationship between Vitamins, Total Phenolic and Total Flavonoid Content and Antioxidant Activities in Various Honey Types. *Molecules*, 26(15), 4399.



## TNP-445

# Phytochemical Analysis of Ethanol Extract from Stingless Bee (*Tetragonula laeviceps* Smith) Honey and Its Anti-Acnes Activity

Nova Hariani<sup>1,2</sup>, Syafrizal<sup>1</sup>, Andi Mismawati<sup>3</sup>, Ritbey Ruga<sup>2,4\*</sup>

<sup>1</sup>Department of Biology, Faculty of Mathematics and Natural Sciences, Mulawarman University, Samarinda 75123, East Kalimantan, Indonesia

<sup>2</sup>Research Center for Medicines and Cosmetic from Tropical Rainforest (PUI-PT OKTAL), Mulawarman University, Samarinda 75119, East Kalimantan, Indonesia

<sup>3</sup>Department of Fisheries Product Technology, Faculty of Fishery and Marine Science, Mulawarman University, Samarinda 75123, East Kalimantan, Indonesia

<sup>4</sup>Department of Chemistry, Faculty of Mathematics and Natural Sciences, Mulawarman University, Samarinda 75123, East Kalimantan, Indonesia

Corresponding Author\*: [ritbey.r@fmipa.unmul.ac.id](mailto:ritbey.r@fmipa.unmul.ac.id)

## Abstract

Ethanol extract of stingless bee (*Tetragonula laeviceps*) honey were conducted for its phytochemical analysis and anti-acnes potential by using agar well diffusion and micro-dilution methods to conduct diameter of inhibition zone and minimum inhibitory concentration (MIC) value against *Propionibacterium acnes*, respectively. The result of phytochemical analysis demonstrated that ethanol extract of the stingless bee honey contains secondary metabolites namely alkaloids, steroids, triterpenoids, phenolics, saponins, tannins and quinones. Moreover, the ethanol extract displayed anti-acnes activity with diameter inhibition zone of 17.3 mm against *P. acnes* while MIC value at 0.78 µg/mL.

**Keywords:** *Tetragonula laeviceps*, phytochemical analysis, anti-acnes activity.

## Introduction

Skin with acne condition is not annoying like a chronic *disease*. However, human judgment against its condition causes uncomfortable as the effect of unpleasant odor, pricking pain, and unflattering appearance (Omar et al, 2019). Skin acne is occurred by the accumulation of non-lipid-soluble in sebum and is metabolized by *P. acne* into fatty acids that have affected inflammation in the sebaceous glands (Choi et al., 2011; Webster et al., 1995). Some antibiotics have been prescribed occasionally against inflammation as the effect of acne nevertheless, the issues take a place all over the world which the chronic wound has been resistant to commercial antibiotics (Omar et al., 2019; Choi et al., 2011). Consequently, to deal with resistance issues are needed widely exploration of natural products as an alternative to natural antibiotics, particularly for natural anti-acne.

Honey, particularly from Stingless Bees Honey, was declared to have potency as natural antibiotics by some report studies (Beluca et al., 2021; Suntiparapop et al., 2011; Avila et al., 2019). Bees collect and chemically modify plant nectars from rich vegetation and native environment which have specific organic substances for



the 5<sup>th</sup> ICTROPS

International Conference  
for Tropical Studies and Its Applications

Islamic Development Bank 4in1 Project  
Project Implementation Unit  
University of Mulawarman



IsDB  
البنك الإسلامي للتنمية  
Islamic Development Bank



instance, in saliva secretion from abdomens glands and enzymes from cephalic glands (Avila et al., 2018). Honey from the stingless bee has a liquid texture and low crystallization ability (Abd. Jalil et al., 2017) which is stored and left to mature inside colonies thus producing unique taste, uncommon acidity levels, sweetness, and medicinal value (Abd. Jalil et al., 2017; Chuttong et al., 2016; Avila et al., 2019). Syafrizal et al. (2019) reported that *Tetragonula leaviceps* Honey from Samarinda, East Kalimantan has a brown color with sweet and less sour taste which are influenced by several factors including ash content (more ash made the color amber-brown), heat, light exposure, duration of storage, enzymatic reaction, and presence of various compounds (Rao et al, 2016).

Physicochemical characteristics declare that the honey contains low moisture content, low pH, and less ash (Syafrizal et al., 2020; Sungtiprapop et al., 2012). The compositions of honey consist of protein, amino acids, fructose, glucose, sucrose, trace amounts of enzymes, vitamins, Minerals and other substances including phenolic compounds and other secondary metabolic compounds (Muruke, 2014; Beluca et al., 2016; Beluca et al., 2017; Beluca et al., 2019; Beluca et al., 2020; Syafrizal et al., 2019; Khongkwanmueang et al., 2020). These components are likely to play an important role in a number of biological activities of honey. Traditionally in addition to being used as a flavor enhancer, honey has been used by the ancient Chinese, Egyptians, Greeks, Syrians, and Romans to treat various diseases (Rao, et al., 2016). Chancao (2009 & 2013) reported that stingless bees from Thailand produced honey with antibacterial activity. Not only as an anti-bacterial, but honey also has the potential as an antioxidant preventing eye diseases, especially cataracts and glaucoma (Rao et al., 2016). Several researchers described the potency of honey to inhibit the bacterial activity of both gram-negative and gram-positive bacteria nevertheless, inhibition to *P. acne* bacteria has not been exposed yet, and thus the study aims are to analyze the phytochemicals properties and anti-acne activity of ethanol extract of stingless bee (*Tetragonula leaviceps* Smith) from East Kalimantan.

## Methodology

### Materials

Honey Bees *T. leaviceps* were obtained from Honey Woody Park that is located in KM. 26 Balikpapan, East Kalimantan. The honey was collected from the honeycomb using an injection syringe and extracted using ethanol solvent then concentrated using a rotary evaporator. The crude extract was continued test for phytochemicals properties and anti-acne activity.

*Propionibacterium acnes* KCCM 41747 were sub cultured and maintained in nutrient agar (NA) media periodically under suitable conditions. Pure bacterial cultures were first regenerated into liquid medium (nutrient broth, NB) for 18-24 hours at 37°C. All chemicals and reagents for phytochemical analysis also for anti-acne activity are analytical grade and were prepared freshly just before used.

### Phytochemical Analysis

Phytochemicals analysis was carried out to screen the presence of secondary metabolites specifically alkaloids, steroids, triterpenoids, phenolics, saponins, tannins, and quinones. The standard procedures were described by Marlina et al. (2005) with minor modifications

### Determination of Inhibition Zone

Determination of Inhibition zone follows the standard procedures by Clinical Laboratory Standards Institute (CLSI, 2012) with slight modification. The cultured test bacteria were each inoculated on NA media using the

swab technique. A sterile cotton swab was dipped into the NB medium containing the test bacteria, then swab on the NA medium until evenly distributed, then a well was made using a drill with a diameter of 6 mm. Samples with a predetermined concentration are added to the well in the NA medium. The solvent to dissolve the extract was used as a negative control and chloramphenicol was used as a positive control. All treatments were incubated for 24 hours at 37°C. The clear area around the stew shows a positive test based on the following criteria: zone of inhibition >15.0: excellent; 13.1-15.0: very good, 10.1-13.0: good, 8.1-10.0: moderate, 6.1-8.0: less active, 6.0: inactive (Ruga & Chavasiri, 2019).

### Determination of Minimum Inhibitory Concentration

Minimum Inhibitory Concentration (MIC) was determined using a micro-dilution broth according to the Clinical and Laboratory Standards Institute protocol (CLSI, 2012) and using a resazurin colorimetric assay on a 96-well microplate (Sarker et al., 2007; Cuah et al., 2014). The MIC value is defined as the lowest concentration at which the test sample still has activity. *T. leaviceps* honey sample (200 g/ml) as the main concentration was dissolved ethanol which was then varied in concentration by dilution twice in NB media. Next, NB was added to a 96-well microplate, then test samples with different concentrations were added. After that, the bacterial suspension was added and incubated at 37°C for 24 hours. For the colorimetric test, resazurin (0.01%) was added to the microplate and incubated again for 10-30 minutes. The lowest concentration that does not change from blue to pink is indicated as the MIC value. The test was carried out simultaneously with the use of chloramphenicol as a positive control and negative control for wells that were not treated with bacteria.

### Statistical Analysis

The result of phytochemicals analysis are expressed in symbols positive (available) and negative (unavailable). The Inhibition zone and MIC are revealed by mean  $\pm$  standard deviation of three parallel measurement

## Results and Discussion

Phytochemical analysis was carried out, which provided information about the secondary metabolite content of the ethanol extract of *T. leaviceps* honey (TLH). Qualitative phytochemicals analysis of stingless bee honey revealed a wide range of secondary metabolites components (Table 1.), which have various groups of substances and that had obtained such as alkaloids, steroids, triterpenoids, saponins, quinones, and phenolics. The presence of the components may play an essential role in the bioactivity and showed the honey properties of *T. leaviceps*.

**Table 1.** The result of phytochemicals analysis from ethanol extract of *T. leaviceps* Smith honey

Phytochemicals	Existence
Alkaloids	+
Steroids	+
Triterpenoids	+
Flavonoids	-
Saponins	+
Quinone	+
Phenolic	+

Note: + (detected), - (no detected)



Syafrizal et al. (2020) reported the slightly different result of the phytochemical component from TLH in Samarinda which contained alkaloids, tannins, flavonoids, and triterpenoids, however, the presence of saponins and steroids was undetected otherwise, flavonoids were not found in this study. It may be because of the small quantity so that was invisible when analysis. Several species of stingless bees scattered in several cultivated areas in East Kalimantan show the content of alkaloids nevertheless none of them contain steroids (Syafrizal et al., 2020). The number of honey constituents may be influenced by multiple factors, including environmental aspects such as the availability of flowers around the bees and the climate properties (Avila et al., 2018). Alkaloids have the function to inhibit enzymes glucose 6-phosphatase, fructose, 1, 6-biophosphatase, thereby stimulating the inhibition of glucose synthesis which results in a decrease in glucose levels and can increase the oxidation of glucose glycogen (Wild et al., 2004). Triterpenoids are volatile compounds that produce the odor or aroma given off by honey. It also plays tremendous part in the biological activities of the honey essential oil extract, such as antimicrobial and anti-inflammatory activities (Bankova et al., 2014). Moreover, phenolics are reputable as a class of bioactive compounds that shows strong in vitro and in vivo antioxidant effects (Avila et al., 2016).

Determination of antibacterial activity was carried out by the agar diffusion method. This method is very simple and easier to measure the clear zone or inhibition zone formed. The results of the antibacterial test of the stingless bee honey and chloramphenicol (positive control) with the agar diffusion method showed very good inhibition. Based on these results, the MIC test was performed to determine the minimum inhibitory concentration of *P. acne*. The inhibition and MIC values are shown in table 2.

**Table 2.** The Inhibition Zone and Minimum Inhibitory Concentration (MIC) values of ethanol Extract of *T. leviceps* Smith Honey and Chloramphenicol

<b>Zone Inhibition</b>	<b>Inhibition Values</b>
Sample of 100 µg/ml	17.3±0.9
Chloramphenicol of 0.5 µg/ml	25.0 ± 0.0
<b>Minimum inhibitory Concentration</b>	<b>MIC Value (µg/ml)</b>
Sample	0.78
Chloramphenicol	0.039

According to Ruga and Chavasiri (2019), the criteria or provisions for antibacterial strength can be determined by identification of the clear zone or inhibition zone formed where if the inhibition zone is >15mm it can be declared that the antibacterial ability of a sample is excellent, the inhibition zone is from 13.1 to 15.0 mm is very good while 10.1-13.0 mm shows good inhibition, the zone of inhibition is 8.1-10.0 mm is moderate and 6.1-8.0 mm indicates the antibacterial strength is not good. In addition, the inhibition zone below 6.0 mm means that it does not have antibacterial activity. The zone of inhibition (ZOI) of TLH demonstrated 17,3±0,9 mm at a concentration of 100 ppm, which was categorized as excellent. It indicated that bacteria have a susceptible response toward the honey. Continuously, the diluted sample showed a lower MIC value of 0.78 µg/mL. Compared with the TLH from Thailand, TLH from Balikpapan is most active against the activity of *P. acne* bacteria which is not detected with TLH from Chantaburi and Trat Province in Thailand (Suntiparapop et al., 2012). The complexity of physicochemical properties, phytochemical compounds, and other major compounds, that are influenced by the flower resins, may have synergetic action for increased the bioactivity



the 5<sup>th</sup> ICTROPS

International Conference  
for Tropical Studies and Its Applications

Islamic Development Bank 4in1 Project  
Project Implementation Unit  
University of Mulawarman



IsDB  
البنك الإسلامي للتنمية  
Islamic Development Bank



of TLH. The antimicrobial capacity of honey, in this case, is anti-acne, maybe because of a synergistic combination among low pH, high osmolarity, and certain molecules such as hydrogen peroxide, peptides, alkaloids, volatile compounds including triterpenoids, saponins, and other components. Even though honey has been diluted and its hyperosmolarity is reduced, honey is still able to inhibit bacterial activity due to the acids produced through the oxidation of glucose by the enzyme glucose oxidase to form high gluconic acid with hydrogen peroxide as a byproduct (Chancao et al., 2009; Chancao et al., 2013)). The results of this study indicate that TLH has potential as an antibacterial agent, especially against bacteria that cause skin infections with MIC values below 10 µg/mL, comparable to chloramphenicol which was used as a standard or positive control in this study showing the same MIC value against the test bacteria, namely 0.039 µg/mL.

## Conclusions

The results of the phytochemical analysis obtained on the ethanolic extract of *T. laeviceps* honey revealed many things that were similar to the results of other previous studies. Inhibitory activity against *P. acne* bacteria showed excellent inhibition with a MIC value of 0.78 g/mL. Based on the results of the phytochemical analysis and anti-acne activity, it is feasible to consider that *T. laeviceps* honey may have some therapeutic potentials as well as skincare. However, clinical studies have to be evaluated to investigate the effects in-vivo.

## ACKNOWLEDGEMENT

The authors are grateful to Project Implementation Unit *Islamic Development Bank* (PIU-ISDB) research grant (No.303/UN17.11/PL/2020), Mulawarman University, and Woody Park Balikpapan for their hospitality and facilities support for providing this research.

## REFERENCES

- Abd Jalil, M. A., Kasmuri, A. R., & Hadi, H. (2017). Stingless bee honey, the natural wound healer: A review. *Skin Pharmacology and Physiology*, 30(2), 66-75. <https://doi.org/10.1159/000458416>
- Avila, S., Beux, M. R., Ribani, R. H., & Zambiazzi, R. C. (2018). Stingless bee honey: Quality parameters, bioactive compounds, health-promotion properties and modification detection strategies. *Trends in Food Science & Technology*, 81, 37-50. <https://doi.org/10.1016/j.tifs.2018.09.002>
- Ávila, S., Hornung, P. S., Teixeira, G. L., Malunga, L. N., Apea-Bah, F. B., Beux, M. R., ... & Ribani, R. H. (2019). Bioactive compounds and biological properties of Brazilian stingless bee honey have a strong relationship with the pollen floral origin. *Food Research International*, 123, 1-10. <https://doi.org/10.1016/j.foodres.2019.01.068>
- Bankova, V., Popova, M., & Trusheva, B. (2014). Propolis volatile compounds: chemical diversity and biological activity: a review. *Chemistry Central Journal*, 8(1), 1-8. <https://doi.org/10.1186/1752-153X-8-28>
- Biluca, F. C., Braghini, F., Gonzaga, L. V., Costa, A. C. O., & Fett, R. (2016). Physicochemical profiles, minerals and bioactive compounds of stingless bee honey (Meliponinae). *Journal of Food Composition and Analysis*, 50, 61-69. <https://doi.org/10.1016/j.jfca.2016.05.007>



the 5<sup>th</sup> ICTROPS

International Conference  
for Tropical Studies and Its Applications

Islamic Development Bank 4in1 Project  
Project Implementation Unit  
University of Mulawarman



IsDB  
البنك الإسلامي للتنمية  
Islamic Development Bank



- Biluca, F. C., de Gois, J. S., Schulz, M., Braghini, F., Gonzaga, L. V., Maltez, H. F., ... & Fett, R. (2017). Phenolic compounds, antioxidant capacity and bioaccessibility of minerals of stingless bee honey (Meliponinae). *Journal of Food Composition and Analysis*, 63, 89-97. <https://doi.org/10.1016/j.jfca.2017.07.039>
- Biluca, F. C., Bernal, J., Valverde, S., Ares, A. M., Gonzaga, L. V., Costa, A. C. O., & Fett, R. (2019). Determination of free amino acids in stingless bee (Meliponinae) honey. *Food Analytical Methods*, 12(4), 902-907. <https://doi.org/10.1007/s12161-018-01427-x>
- Biluca, F. C., da Silva, B., Caon, T., Mohr, E. T. B., Vieira, G. N., Gonzaga, L. V., ... & Costa, A. C. O. (2020). Investigation of phenolic compounds, antioxidant and anti-inflammatory activities in stingless bee honey (Meliponinae). *Food Research International*, 129, 108756. <https://doi.org/10.1016/j.foodres.2019.108756>
- Biluca, F. C., Braghini, F., de Campos Ferreira, G., Costa dos Santos, A., Helena Baggio Ribeiro, D., Valdemiro Gonzaga, Vitali, L., Amadeu, M.G., Oliveira Costa, A. C., & Fett, R. (2021). Physicochemical parameters, bioactive compounds, and antibacterial potential of stingless bee honey. *Journal of Food Processing and Preservation*, 45(2), e15127. <https://doi.org/10.1111/jfpp.15127>
- Chanchao, C. (2009). Antimicrobial activity by *Trigona laeviceps* (stingless bee) honey from Thailand. *Pak J Med Sci*, 25(3), 364-369.
- Chanchao, C. (2013). Bioactivity of Honey and Propolis of *Tetragonula laeviceps* in Thailand. In *Pot-Honey* (pp. 495-505). Springer, New York, NY.
- Choi, J. S., Bae, H. J., Kim, S. J., & Choi, I. S. (2011). In vitro antibacterial and anti-inflammatory properties of seaweed extracts against acne inducing bacteria, *Propionibacterium acnes*. *Journal of environmental biology*, 32 (3), 313 – 318.
- Chuttong, B., Chanbang, Y., Sringarm, K., & Burgett, M. (2015). Effects of long term storage on stingless bee (Hymenoptera: Apidae: Meliponini) honey. *Journal of Apicultural Research*, 54(5), 441-451. <https://doi.org/10.1080/00218839.2016.1186404>
- CLSI. 2012. *Methods for Dilution Antimicrobial Susceptibility Tests for Bacteria That Grow Aerobically; Approved Standard-Ninth Edition*. Clinical and Laboratory Standards Institute, United State of America. 12-19.
- Chuah, E. L., Zakaria, Z. A., Suhaili, Z., Bakar, S. A., & Desa, M. N. M. (2014). Antimicrobial activities of plant extracts against methicillin-susceptible and methicillin-resistant *Staphylococcus aureus*. *Journal of Microbiology Research*, 4(1), 6-13. <https://doi.org/10.5923/j.microbiology.20140401.02>
- Khongkwanmueang, A., Nuyu, A., Straub, L., & Maitip, J. (2020). Physicochemical Profiles, Antioxidant and Antibacterial Capacity of Honey from Stingless Bee *Tetragonula laeviceps* Species Complex. In *E3S Web of Conferences* (Vol. 141, p. 03007). EDP Sciences.
- Marliana S.D., Suryanti V., & Suyono. (2005). Skrining Fitokimia dan Analisis Kromatografi Lapis Tipis Komponen Kimia Buah Labu Siam (*Sechium edule* Jacq.Swartz.) dalam Ekstrak Etanol. *Biofarmasi*, 3 (1), 26-31.
- Muruke, M. H. (2014). Assessment of antioxidant properties of honeys from Tanzania. *Journal of Biology, Agriculture and Healthcare*, 4(27), 22-29.



the 5<sup>th</sup> ICTROPS

International Conference  
for Tropical Studies and Its Applications

Islamic Development Bank 4in1 Project  
Project Implementation Unit  
University of Mulawarman



IsDB  
البنك الإسلامي للتنمية  
Islamic Development Bank



- Omar, S., Mat-Kamir, N.F., & Sanny, M. (2019). Antibacterial activity of Malaysian produced stingless-bee honey on wound pathogens. *Journal of Sustainability Science and Management*, 14 (3), 67-79.
- Rao, P. V., Krishnan, K. T., Salleh, N., & Gan, S. H. (2016). Biological and therapeutic effects of honey produced by honey bees and stingless bees: a comparative review. *Revista Brasileira de Farmacognosia*, 26, 657-664. <https://doi.org/10.1016/j.bjp.2016.01.012>
- Ruga, R., & Chavasiri, W. (2019). Enhancing Antibacterial Activity by Combination of Chloramphenicol with Constituents from *Dracaena cochinchinensis* (Lour.) SC Chen. *Anti-Infective Agents*, 17(1), 74-80. <https://doi.org/10.2174/2211352516666180730115216>
- Sarker, S. D., Nahar, L., & Kumarasamy, Y. (2007). Microtitre plate-based antibacterial assay incorporating resazurin as an indicator of cell growth, and its application in the in vitro antibacterial screening of phytochemicals. *Methods*, 42(4), 321-324. <https://doi.org/10.1016/j.ymeth.2007.01.006>
- Suntiparapop, K., Prapaipong, P., & Chantawannakul, P. (2012). Chemical and biological properties of honey from Thai stingless bee (*Tetragonula leviceps*). *Journal of Apicultural Research*, 51(1), 45-52. <https://doi.org/10.3896/IBRA.1.51.1.06>
- Syafrizal., Ramadhan, R., Kusuma, I. W., Egra, S., Shimizu, K., Kanzaki, M., & Tangkearung, E. (2020). Diversity and honey properties of stingless bees from meliponiculture in East and North Kalimantan, Indonesia. *Biodiversitas Journal of Biological Diversity*, 21(10).
- Webster, G. F. (1995). Inflammation in acne vulgaris. *Journal of the American Academy of Dermatology*, 33(2), 247-253. [https://doi.org/10.1016/0190-9622\(95\)90243-0](https://doi.org/10.1016/0190-9622(95)90243-0)
- Wild, S., Gojka, R., Anders, G., Richard, S., & Hilary, K. 2004. Global prevalence of Diabetes. *Diabetes Care*, 27 (5), 1047-1053

## TNP-452

### Prototype of Smart Trash bin based by Microcontroller with Telegram communication

Wisnu Candra Margono<sup>1</sup>, Siska Mayra Andini<sup>2</sup>, Idham Apriliyanto<sup>3</sup>, Ulwan Fauzan Azhari<sup>4</sup>,  
Nur Rani Alham<sup>5</sup>

Department of Electrical Engineering, Mulawarman University, Indonesia

Corresponding Author\* : wisnucandra03@gmail.com

#### Abstract

Waste is one of the crucial issues live. Amount of waste scattered is a manifestation of people's indifference to the cleanliness of surrounding environment. Often lazy feeling to dispose out the bin is also caused by the large number of conventional bin cans that still use manual ways to open and close them. In additional a clean environment, it's necessity for today's society. Many people install surveillance cameras at home to monitor the house when it is empty, but when the cameras detects the presence of unwanted people, the owner isn't notified immediate. Current technological developments are increasingly rapidly motivating humans to overcome existing problems. This study aims to design an automatic bin can with a security system with a surveillance camera that directly notifies homeowners through existing messaging applications. This smart bin built using Ultrasonic sensors and PIR sensors, servo motors, and ESP32-CAM which are all connected to the microcontroller and utilize Telegram Messenger as monitoring remote.

**Keywords:** Smart trash bin, Ultrasonic sensors, PIR sensors, Home security

#### Introduction

Along with the advancement of the level of people's thinking accompanied by technological developments in every aspect of life, humans try to overcome the problems that arise in the surrounding environment (K. Fatmawati, 2020). Basically, humans are living beings who want cleanliness and security in their living environment. There is still a lot of garbage that is scattered is the result of many people who do not care about environmental cleanliness (Sukarjadi, 2017).

One of the environmental issues that is often encountered is waste. Garbage is an important issue because waste can interfere with human health and cause environmental pollution (I. Purnama, 2020). Often the feeling of laziness to throw garbage in the trash arises because the available trash cans still use a simple way to open and close them. The direct contact between hands and dirty trash cans will make hands dirty, smelly, and infected with bacteria (A. Wuryanto, 2019). Therefore, to make the environment clean and healthy, innovative steps are needed to make smart trash bins (M. Furqan, 2020). In addition to a clean environment, a safe environment is a community need. Utilization of technology Internet of Things (IoT) to control home security remotely using existing messaging applications and PIR sensors that can detect human presence is an additional feature in making smart trash bins (M. I. Kurniawan, 2018).



Based on this, it is necessary to have a smart trash can accompanied by a security system. The trash can is designed to open automatically based on the distance of the object using ultrasonic sensors and PIR sensors (Passive Infrared Receiver) to detect human body heat, as well as ESP32-CAM as a module camera to photograph objects as a security feature, all of which are connected to Arduino UNO R3 and FTID.

## Methodology

### Research Stage

Broadly speaking, the research procedures used are illustrated in the flowchart in Figure 1. This research method starts from literature study, system design, prototype making, prototype testing, work analysis of the system, and report generation.

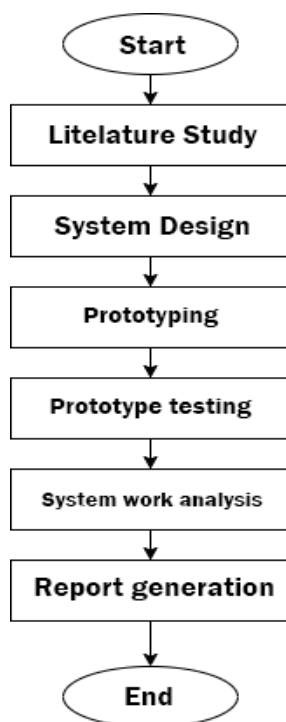

**Figure 1.** Flowchart of research stage

### Time, Place, and Tools

The research was conducted in April 2021, in Samarinda City. Table 1 shows the components and tools used in this study.

**Table 1.** Components used

No	Component	Quantity
1.	Arduino UNO R3	1
2.	Ultrasonic	1
3.	Sensor PIR	1
4.	Motor Servo	1
5.	DFPlayer MP3	1
6.	FTDI	1
7.	Card Memory	1
8.	Card Jumper	1
9.	Esp 32-CAM	1
10.	Adapter	1
11.	USB Cable	1
12.	Nylon Rope	Sufficiently
13.	Plywood Board	Sufficiently
14.	Laptop	1
15.	Trash can	1

### System Design

a. An overview of the design of this smart trash can prototype has two systems in it, namely a system for detecting objects with ultrasonic sensors and PIR sensors. The system consists of two designs, namely hardware design which includes electrical physical components and software design which includes source code on the microcontroller Arduino.

b. The smart trash can prototype block diagram uses a simple design concept, the design concept includes input, process, and output.

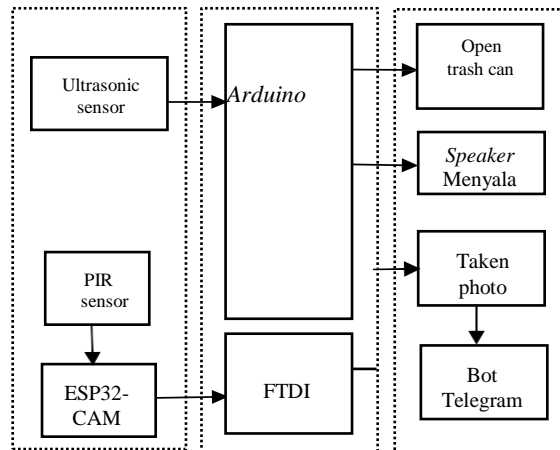

**Figure 2.** Block Diagram of Component Design System Hardware

### c. Planning Flowchart In General

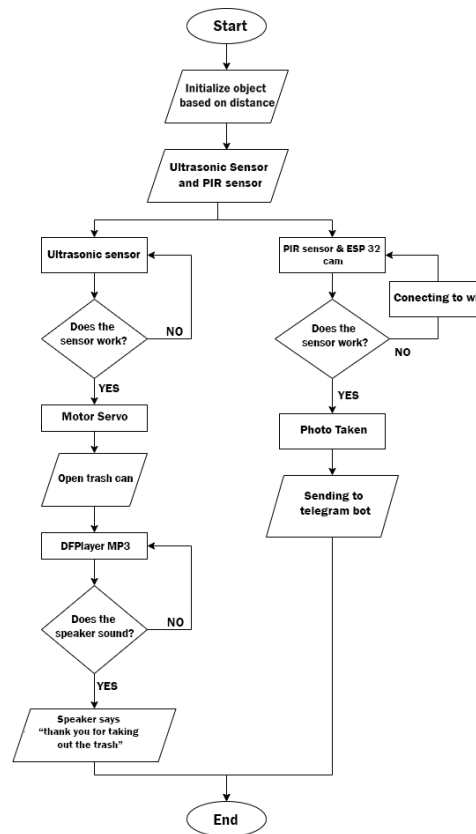

**Figure 3.** Flowchart Smart Trash

Description of Figure 3 is when Arduino and FTDI are connected to an electric current, the ultrasonic sensor and PIR sensor will work. The ultrasonic sensor will detect the movement of the object and send input to the servo to open the lid of the trash can, then the speaker will sound "Thank you for taking out the trash". The PIR sensor will work if the module wifi on the ESP32-CAM is connected to an internet connection. When the PIR sensor detects the movement of an object, the ESP32-CAM will take a picture of the detected object, then send the results to Telegram Messenger as a security feature.

### d. Overall System Circuit

In Figure 4 shows the design of a microcontroller system with other electronic devices and the descriptions of the connected pins are shown in Table 2



the 5<sup>th</sup> ICTROPS

International Conference  
for Tropical Studies and Its Applications

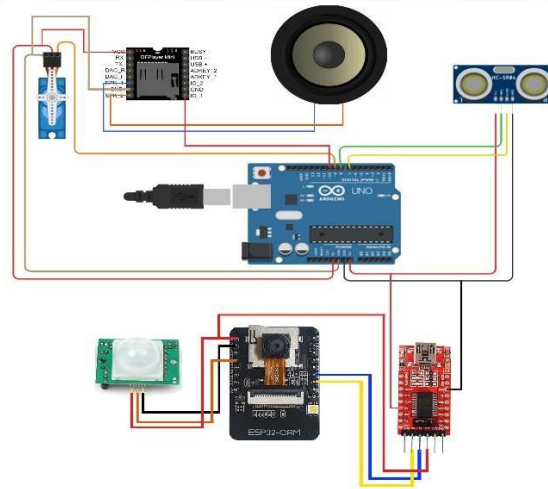

**Figure 4.** Overall System Circuit

**Table 2.** Explanation of the Pins Connected to the Microcontroller

Arduino	Speaker	Explanation	FTDI	ESP 32 Cam	Explanation
PIN 7		Echo Ultrasonik	RX		GPIO 1/UOT
PIN 8		Tring Ultrasonik	TX		GPIO 3/UOR
PIN 9		Data Servo	VCC		5V ESP32-CAM
PIN 10		IO_1 DFPlayer Mini	5V		VIN/5V Arduino
5V		VCC Servo dan VCC DFPlayer Mini	GND		GND 2 Arduino
GND 1		Ground Servo dan DFPlayer Mini		5V	VCC PIR
GN 2		Ground Ultrasonik		GND	Ground PIR
VIN		VCC Ultrasonik			
	1	SPK 1 DFPlayer			
	2	SPK 2 DFPlayer			

Results and Discussion

The result of the design of prototype space junk accompanied smart security system where all the components have been installed and will be tested shown in Figure 5.



**Figure 5.** Results of Smart Trash Can Prototype Design

The system testing phase is carried out to determine whether the system has been running according to the initial design or not. The ultrasonic sensor will be tested according to the program entered on the Arduino, namely the sensor will detect objects with a maximum distance of 20 cm, if more than that distance, the sensor cannot detect objects and the trash can will not open. The PIR sensor will be tested based on the sensitivity of the sensor to the distance of the object, testing the optimum angle of the PIR sensor, and the success of sending photos to the Telegram Messenger application .

#### A. Ultrasonic Sensor Test

The following is a test when the trash can is connected to an electric current. The ultrasonic proximity sensor will detect objects with a maximum distance of 20 cm, then the servo motor will open the trash can cover for 10 seconds and will close automatically. The test results are shown in Table 3.

**Table 3.** Ultrasonic Sensor Test Results

Object Distanc (cm)	Sensor Condition Distance	Servo	Speaker
5	Detected	Active	Active
20	Detected	Active	Active
30	No Detected	No Active	No Active



**Figure 6.** Close the Trash Open

### B. PIR Sensor Distance Sensitivity Testing

Table 4 shows the results of testing the sensitivity of the PIR sensor to the distance of the object and the photo taken by the ESP32- Cam.

**Table 4.** PIR Sensor Test Results Against Object Distance

Distance (meter)	Detection Results (Yes/No)	Photo Taken
1	Yes	Yes
2	Yes	Yes
3	Yes	Yes
4	Yes	Yes
5	Yes	Yes
6	Yes	Yes
7	Yes	Yes
8	No	No
9	No	No

Table 4 shows that the PIR sensor can detect objects with a maximum distance of 7 m with the object moving. Meanwhile, when testing with a stationary object, the sensor is only able to detect objects with a maximum distance of 30 cm.

### C. PIR Sensor Detection Angel Testing

Testing the detection angle of the PIR sensor is needed to determine the wide range of object angles so that the sensor can detect it. Table 5 shows the data on the results of the tests that have been carried out.

**Table 5.** Testing Results of the PIR Sensor Detection Angle

Object Angle	Detection Results (Yes / No.)	Photo Takes
0°	No	No.
30°	Yes	Yes
40°	Yes	Yes
60°	Yes	Yes
90°	Yes	Yes
120°	Yes	Yes
140°	Yes	Yes
150°	No.	No
180°	No	No.

#### D. Overall Security System Test Result

The results of testing the security system with PIR sensors and ESP32-CAM which were carried out randomly starting from testing the PIR sensor to detect the presence of humans, the camera taking pictures of detected objects, until the user receiving messages through the Telegram Messenger application will be shown in Table 6.



**Figure 7.** Appearance on the Telegram Messenger Application



**Table 6.** Overall Security System Test Results

Test to -	Object Distance (meter)	Object Angle Position	PIR Sensor Condition	Camera Condition	User Accepted Photos
1	1	40°	Detected	<i>Standby</i>	Succeed
2	3	90°	Detected	<i>Standby</i>	Succeed
3	6	120°	Detected	<i>Standby</i>	Succeed
4	7	150°	No Detected	<i>Standby</i>	No
5	8	180°	No Detected	<i>Standby</i>	No

Table 6 shows the overall test results of the security system contained in the smart trash bin by testing the distance and angle of the object at random. The test was carried out 5 times with variations in object distances, namely 1 m, 3 m, 6 m, 7 m, and 8 m; variations in object detection angles are 40°, 90°, 120°, 150°, and 180°.

In the first test, the object is 1 meter away and the angular position of the object to the sensor is 40°, the PIR sensor successfully detects the object, with the camera condition being standby photos successfully accepted by the user. In the second test, namely the distance of the object to the sensor is 3 meters and the position of the object's angle is 90°, the PIR sensor has successfully detected the object and the photo has been successfully received by the user. In the fourth test, the object is 7 meters away and the angular position of the object to the sensor is 150°, even though the camera is in standby, but the user does not receive the photos in the Telegram application Messenger, this is because according to the previous experimental data that the PIR sensor cannot detect objects. if the detection angle is greater than equal to 150°.

### Conclusions

Based on the results of the tests and analyzes that have been carried out, it can be concluded that:

1. Ultrasonic Sensor HC-SR04 successfully detects objects with a maximum distance of 20 cm, then the lid of the trash can will open for 10 seconds and close automatically.
  2. The speaker can function properly and make sound when the trash can lid is open.
  3. The PIR sensor can detect objects with a maximum distance of 7 meters.
  4. The maximum angle of detection of the PIR sensor on objects horizontally is between 30° to 140°.
- The security system in this research prototype works well in detecting objects, photographing objects, and sending the results to users remotely with the Telegram application Messenger.

## REFERENCES

- A. Wuryanto, N. H. (2019). Perancangan Sistem Tempat Sampah Pintar Dengan Sensor HCRSF04 Berbasis Arduino Uno R3. *Paradig,-J.Komput dan Inform*, vol. 21, no.1, pp. 55-60.
- I. Purnama, S. Z. (2020). Rancang Bangun Tempat Sampah Otomatis Pada Univesitas Labuhanbatu. *Informatika : Fakultas Sains dan Teknologi*, vol. 8, no. 2, pp. 81-84.
- K. Fatmawati, E. S. (2020). Rancang Bangun Tempat Sampah Pintar Menggunakan Sensor Jarak Berbasis Mikrokontroler Arduino. *Riau J. Comput, Sci*, Vol. 6, no. 2, pp. 124-134.
- M. Furqan, R. K. (2020). Tempat Sampah Pintar Dengan Logika Fuzzy Berbasis NodeMCU. *Indones. J. Comput, Sci*, Vol. 9, n0. 1, pp. 11-21.
- M. I. Kurniawan, U. S. (2018). Internet of Things : Sistem Keamanan Rumah berbasis Raspberry Pi dan Telegram Messenger. *Elkomika J. Tek, Energo ELEktro. Tek, Telekomun, Tek Elektron*, vol. 6, no. 1, pp. 1.
- Sukarji, D. T. (2017). Perancangan Dan Pembuatan Smart Trash Bin Berbasis Arduino Uno DI Univesitas Maarif Hasyim Latif. *Tek. Eng. Sains J*, vol. 1, no. 2, pp. 101-101.

## TNP-457

# Purun Plant in East Kalimantan, The Endemic Plants in Peat and Swamp Areas as A Humid Tropical Local Commodity with Superior Potential

**Odit F. Kurniadinata<sup>1\*</sup>, Penny Pujowati<sup>1</sup>, Khoiru Indana<sup>1</sup>, Donny Dhonanto<sup>1</sup>,  
Agung E. Nugroho<sup>1</sup>**

The Faculty of Agriculture, Universitas Mulawarman, Samarinda,  
East Kalimantan Province, Indonesia

*Corresponding Author\*:* [odit.ferry@faperta.unmul.ac.id](mailto:odit.ferry@faperta.unmul.ac.id)

## Abstract

Purun plant is one of the endemic plants that naturally grows wild in peat and swamp areas. It is commonly found in peat and swamp areas in Indonesia, including in East Kalimantan. Purun belongs to the Cyperaceae family. This plant is a typical plant in swamp areas. Swamp land is land for a long time during the year is always saturated with water or inundated. Purun plants are wild plants that can adapt well to tidal swamps, acid sulfate and peat. This plant has many benefits for the growing environment, including as an absorber and water filter that can maintain the environmental conditions of tidal swamps and peat because resistant to high soil acidity (pH 2.5-3.5), as indicator vegetation for acid sulphate soils, as an alternative hosts for pests and shelter or natural enemy habitat, as biofilters, biofertilizers and it can help maintains soil moisture to prevent fires during the dry season. Recently, at least 11,000 ha of peatland are moderately to heavily damaged in Kabupaten Kutai Barat and 15,000 ha in Kabupaten Kutai Kartanegara, while those classified as lightly damaged are around 49,000 ha in Kabupaten Kutai Barat and 178,000 ha. in Kabupaten Kutai Kartangara. The increasingly degradation of peatlands in East Kalimantan must be controlled to avoid negative ecological impact. The restoration of degraded peat ecosystems can only be done by rewetting the land. The existence of peatlands as purun plant habitat in East Kalimantan cannot be separated from the humid tropical climate conditions. Humid tropical climate is a condition in the wet tropics which is located between 15° North Latitude and 15° South Latitude. Humid tropical climate is characterized by relatively high air humidity, high rainfall and air temperature. Recently, Kalimantan people know three types of purun plant, namely purun danau, purun tikus and purun bajang. The purun danau has a fundamental difference size when compared to the purun tikus and purun bajang, also the purun danau leaves are tougher like woody and have more distinct lines than other types. Purun danau also has a cavity that looks like a bamboo stick. The objectives of this project are: 1) to educate the community around peatlands and tidal swamps to participate in preserving the environment; 2) transferring and increasing the knowledge and skills of the people around peat and tidal swamps to appropriate technology for cultivate and use purun plants to be some product with high economic value. The result from this project can be a role model and obtain outcomes that support sustainable agriculture and environmental sustainability of peatlands and tidal swamps, specifically in East Kalimantan.

**Keywords:** Purun, Local Plant, Peatland, Swamp, Sedge Plant

## Introduction

Kalimantan Island has peatlands which are still forest (include mangroves and peat swamps) and

shrubs around 2,402,362 ha (49.9%) and 1,373,563 ha (28.6%). Mangrove forests and peat swamps are generally found on the West coast, South coast, and East coast (at the mouth of the Mahakam River), East Kalimantan. Peatlands are one type of wetland ecosystem. The existence of peatlands is currently threatened under pressure by various human activities which has potential to damage this ecosystem.

The Peatlands damage can also cause by fires and mining activities. Peat fires will contribute to global climate change as a result of the increase in greenhouse gas emissions released into the air. Peat fires affect the main function of peatland as a source of biodiversity and a place to store carbon in nature. Peat and swamp areas in its natural condition is overgrown with various types of aquatic plants, both types of grasses (reeds, sedges, and rushes), shrubs and timber/forest vegetation, the soil is saturated with water or has shallow.

Purun is one of the endemic plants that naturally grows wild in peat and swamp areas. Purun is commonly found in peat and swamp areas in Indonesia, such as South Kalimantan, Central Kalimantan, West and East Kalimantan, South Sumatra and Riau. Purun belongs to the family *Cyperaceae*. This plant is a typical plant in swamp land. Swamp land is land for a long time during the year is always saturated with water or inundated. Purun is a plant that lives in the wild naturally in areas of peat swamp, tidal swamp and river areas that are acidic sulphate. The population of purun is quite a lot found around peat swamps and tidal swamps, as well as around Mahakam river area in East Kalimantan. Except for the threat of damage that occurs, this large population has not been widely used by the surrounding community even though purun has various potentials and is beneficial for the environment and other alternative materials. It is necessary to identify purun plants in East Kalimantan as potential superior plants. Purun is one of the endemic plants that naturally grows wild in peat and swamp areas. The objectives of this project are: 1) to educate the community around peatlands and tidal swamps to participate in preserving the environment; 2) transferring and increasing the knowledge and skills of the people around peat and tidal swamps to appropriate technology for cultivate and use purun plants to be some product with high economic value.

## Method

The research method used in this research is descriptive analysis method or descriptive research. The descriptive analysis method used in this study aims to identification the types of purun plant in East Kalimantan.

## Result

The identification results obtained three types of purun that are known in Kalimantan, namely rat purun (purun tikus), bajang purun (purun bajang) and lake purun (purun danau). Purun tikus (*Eleocharis dulcis*) is the most commonly found in swamp areas. The stems of purun tikus contain long coarse fibers that make it a suitable material for making mats and can be used as animal feed, especially for swamp buffalo. Purun tikus fiber is a



the 5<sup>th</sup> ICTROPS

International Conference  
for Tropical Studies and Its Applications

Islamic Development Bank 4in1 Project  
Project Implementation Unit  
University of Mulawarman



IsDB  
البنك الإسلامي للتنمية  
Islamic Development Bank



cellulose material so it has a complex structure. Purun tikus fiber can also act as an adsorbent medium to reduce the concentration of mercury (Hg), COD, and TSS in gold mining wastewater. Purun tikus is perennial, rhizomatous, semi-aquatic plant. Rhizome short with elongated stolons, each one often terminating in a zoned, depressed globose, brownish to blackish corm, 1-4 cm in diameter. Stem erect, terete, tufted, 40-70 cm tall, 3-10 mm in diameter, longitudinally striate, hollow, smooth, greyish to glossy dark green. Leaves reduced to some bladeless basal sheaths, 3-10 m long, membranous, oblique or truncate at the apex, reddish brown to purple. Inflorescence a single, terminal, many-flowered spikelet, cylindrical, as thick as or somewhat thicker than the stem.

Purun Bajang itself mostly lives in East Kalimantan, especially in tidal swamps and acidic lakes, such as in Sambutan District, Samarinda City, East Kalimantan. Purun bajang is the name of the community for the type of purun that is large and long. Purun bajang has many physical similarities with the purun tikus, but there are some differences, namely its large diameter and length of stem which reaches 2 meters. The general difference between purun bajang and purun tikus is the fibers are more brittle than purun tikus and much larger in size than purun tikus. People usually use the purun bajang for animal feed, especially cows and a substitute material for purun tikus as a material for making mats.

The third purun is Purun Danau (*Lepironia articulata*). This plant has a fundamental difference from purun tikus and purun bajang, which is that it is much larger in size than purun tikus and purun bajang and has stem that are harder like woody and with internode lines clearly than other types of purun. Purun danau also has a cavity that is similar to a bamboo stick. Purun Danau is perennial plant, rhizome woody, creeping horizontally a few cm below the mud surface, up to about 15 cm × 0.5–1 cm, fleshy at first but becoming woody, has many-noded, internodes about 1 cm long, stems close together, arranged in a row along the rhizome, each one erect, slender, cylindrical, 0.5–2.5(–3.5) m long, 2–8 mm in diameter, smooth and hollow but transversely septate (clearly visible when dried), glaucous or grey-green, clothed at the base with about 3 sheaths and 4–5 scales. Leaves reduced to bladeless sheaths, 3–30 cm long, upper one longest, split on one side, margins overlapping, brownish or reddish. Inflorescence consisting of a single spike-like cluster, apparently lateral owing to the single, erect, culm-like.

All Purun plant can used as kind of product with economical values, some of them are as organic mats and straws (made from the stem of purun plant), and also as forage for animal feed (the case with swamp buffalo in Pandak Daun Village, South Kalimantan). The purun swamp forage has potential as a source of local animal feed which has the advantage of fast growth, the proportions of leaves and stems are fused so that many parts can be utilized.

The limited ability of people living around peat and tidal swamp ecosystems in economic, social, educational, institutional, and political aspects makes them unable to be independent. This condition lead them cannot play a role in maintaining or restoring peat ecosystems. Independence is a process of revival and development of strengths in humans that may have been lost due to dependence, exploitation and subordination.

The independence of the community around peatlands and tidal swamps can be formed through a series of empowerment activities. Empowerment is part of the development paradigm that focuses its attention on all the principal aspects of humans and their environment, starting from aspects of Human Resources (Knowledge, Skills, and Attitudes), material, physical and economic aspects, to managerial aspects including management. all potentials and resources (Jamasy, 2004).



the 5<sup>th</sup> ICTROPS

International Conference  
for Tropical Studies and Its Applications

Islamic Development Bank 4in1 Project  
Project Implementation Unit  
University of Mulawarman



IsDB  
البنك الإسلامي للتنمية  
Islamic Development Bank



Based on the identification of problems that have been carried out, several important problems that will be resolved in this activity can be justified, namely: There is a threat to the peatlands and tidal swamps, especially during the long dry season, namely peatland fires. The peoples around peatlands (the community) has limited knowledge and information regarding the use and good management of peatlands and tidal swamps. Therefore, it is necessary to do some efforts, ie: Education for communities around peatlands to jointly protect the environment. Need to find an alternative business for farmers and fishers, considering that during the rainy season, agricultural land and ponds will be flooded and vice versa during the dry season there is no water and there is a risk of land fires. Produce an environmentally friendly product that has a wide market share and supports resilience in the transportation and marketing process. There is a need for training and assistance for the community in producing purun plant products. It is necessary to find the goot marketing and market chain to support good and sustainable agribusiness system.

Establish good cooperation between academics and the partner in community continuously, to build the good atmosphere of cooperation and develop science and technology that can be applied by the community. The method that can be used is the method of guidance and practice as well as exploring the community's ability to consist of four stages of activities including 1) introduction of appropriate technology and products to members of farmer groups, 2) implementation of information and technology transfer as well as training on cultivation and harvesting of purun plants on the field, 3) implementation of information and technology transfer as well as training on processing, packing and marketing of purun straw products, 4) building agribusiness chain of partners and markets.

### Conclusion

There are three types of purun that are known in Kalimantan, namely rat purun (purun tikus), bajang purun (purun bajang) and lake purun (purun danau). Purun tikus (*Eleocharis dulcis*) is the most commonly found in swamp areas. Purun bajang has many physical similarities with the purun tikus, but there are some differences, namely its large diameter and length of stem which reaches 2 meters also more brittle than purun tikus. Purun Danau (*Lepironia articulata*) is much larger in size than purun tikus and purun bajang and has stem that are harder like woody. All Purun plant can be used as kind of product with economical values, some of them are as organic mats and straws (made from the stem of purun plant), and also as forage for animal feed.

### REFERENCES

- Andriessse, J.P. 1988. Nature and Management of Tropical Peat Soils. Soil Resources, Management & Conservation Service. FAO Land and Water Development Division. FAO, Rome. P 165.
- Barchia, M.F. 2002. Emisi Karbon dan Produktivitas Tanah pada Lahan Gambut yang Diperkaya Bahan Mineral Berkadar Besi Tinggi pada Sistem Olah Tanah yang Berbeda. Disertasi S3, Fakultas Pascasarjana IPB. Bogor.
- Brecht, J.K. 1998. Waterchessnut. Horticultural Sciences Department, University of Florida.
- Budiman, A., M. Thamrin, dan S. Asikin. 1988. Beberapa jenis gulma di lahan pasang surut Kalimantan Selatan dan Tengah dengan tingkat kemasaman tanah yang berbeda. Prosiding Konferensi IX HIGI, Bogor



International Conference  
for Tropical Studies and Its Applications

Islamic Development Bank 4in1 Project  
Project Implementation Unit  
University of Mulawarman



IsDB  
البنك الإسلامي للتنمية  
Islamic Development Bank



2224 Maret 1988.

Direktorat Pengendalian Kerusakan Gambut. 2019. inventarisasi-ekosistem-gambut.  
<http://pkgppkl.menlhk.go.id/> (diakses 2 Agustus 2020)

Irawan, Chairul, Ardiansyah dan Naisha Hanan. 2014. Potensi Hayati Serat Purun Tikus (*Eleocharis dulcis*) Dalam Proses Adsorpsi Kandungan Logam Berat Merkuri (Hg), TSS dan COD pada Limbah Cair Pertambangan Emas. *Jurnal Konversi*. Vol.3 No.1 : 17-24

Kabupaten Kutai Kartanegara Dalam Angka 2019. 2019. BPS. <https://kukarkab.bps.go.id/>. (diakses 2 Agustus 2020)

Lavorel, S., Flannigan, M.D., Lambin, E.F., dan Scholes, M.C., 2007. Vulnerability of Land Systems to Fire: Interactions among Humans, Climate, the Atmosphere, and Ecosystems. *Mitig. Adapt. Strat. Glob Change*, 12:33–53.

Lawrance, H. M. 1958. *Taxonomi of Vascular Plants*. Macmillan Company. New York. Pp 3,6,47

Mitsch, W.J. dan Gosselink, J.M., 2000. *Wetlands*. Third Edition. John Wiley & Sons, Inc. New Jersey, Amerika.

Noor, M. 2004. *Lahan Rawa, Sifat dan Pengelolaan Tanah Bermasalah Sulfat Masam*. Raja Grafindo Persada, Jakarta.

Phillips, V.D., 1998. *Peat swamp Ecology and Sustainable Development in Borneo*. *Biodiversity and Conservation*, 7: 651-671.

Priyatmadi, B.J., Mahbub, Syaifuddin, dan Muslikin. 2006. Adaptasi Tanaman terhadap Sifat Kimia Tanah Sulfat Masam di Kalimantan Selatan. *Kalimantan Scientiae*. Universitas Lambung Mangkurat, Banjarbaru.

Rosihan Adhani dan Husaini. 2017. *LOGAM BERAT SEKITAR MANUSIA*. Lambung Mangkurat University Press.

Wardiono. 2007. (*Eleocharis dulcis* Burm.f.) Trinius ex Henschell.  
<http://www.Kehati.or.id/prohati/browser.php/docsid=478>. Diakses 20 Maret 2021

## TNP-478

# Utilization of Goat Manure Towards PLTB (Biogas) Prototypes in Simple Way

Nur Rani Alham<sup>1</sup>, Bayu Dwi Prabowo<sup>2</sup>, Ira Riyana Sari Siregar<sup>3</sup>, Wisnu Candra Margono<sup>4</sup>,  
Ulwan Fauzan Azhari<sup>5</sup>, Tantra Diwa Larasati<sup>6</sup>

Electrical Engineering, Mulawarman University, Indonesia

Corresponding Author\*: [Nurrani.alham@gmail.com](mailto:Nurrani.alham@gmail.com)

### Abstract

Biogas is a gas that can be processed using the combustion method and the process of anaerobic (without oxygen) digester activity derived from organic materials such as leaves, cattle manure, agricultural waste and household waste. The high methane content in biogas makes biogas very potential as a new renewable energy source at this time. Biogas can be formed on days 4<sup>th</sup> -5<sup>th</sup> after the digester and it is able to reach its peak on days 16<sup>th</sup> -20<sup>th</sup>. 5 kg of goat manure can produce methane gas of 0.493181 m<sup>3</sup> which can generate electricity for approximately 10 minutes. The peak power that can be generated within 10 minutes is 0.057240 Watt and it can turn on LED lights. Current, voltage, and electric power will automatically go down and off when the biogas as fuel runs out of the gallon.

**Keywords:** biogas, goat, electricity

### Introduction

Along with the times and technology, a lot of energy used is non-renewable energy and tends not to change. Energy is an important component in human life, especially in helping human work and as a source of modern human life as it is now. The use of non-renewable energy is getting out of control and gradually tends to run out of non-renewable energy. The uncontrolled use of non-renewable energy is what drives and creates alternative energy such as biogas. Biogas is a fuel with alternative materials which can utilize kerosene and natural gas as fuel. Biogas is a type of bioenergy that comes from organic materials such as human waste, straw, leaves, animal waste that undergo a methanization process or a fermentation process.

Biogas is clean energy that can reduce greenhouse emissions. Biogas contains methane (CH<sub>4</sub>) and the calorific value is quite high ranging from 4,800 – 6,700 kcal/m<sup>3</sup> biogas has the potential to be a new source of renewable energy to replace fossil energy such as natural gas, coal and gasoline (Wahyuni, 2009). Methane gas (CH<sub>4</sub>) has one carbon in each chain which makes combustion more environmentally friendly. Biogas methane gas also contains H<sub>2</sub>S gas which needs a purification process because it can act as an impurity and if it is burned or released in the air it can become SO<sub>2</sub> and SO<sub>3</sub> which are corrosive (Nurkholis Hamidi, 2011).

Many studies have been carried out in analyzing the potential of biogas power plants such as what Nahdia has done in the title "Analysis of Biogas Power Plants Based on the Green Technology Concept, case study in Puter Kembangbahu Village" The results of this study show that 23 m<sup>3</sup>/day of biogas potential can be converted into electrical energy of 1,0005 KWh (Nahdia, 2018). For other studies, such as from Kurniawan who



examined the conversion of biogas energy into electrical energy and the results of his research showed the potential for the dung of 300 goats or sheep to produce electrical energy of 32.4 kWh/day (Kurniawan, 2019). Therefore, in this study, an analysis of the potential of goat waste will be carried out on the prototype of PLTB (Biogas) using 5 kg of goat/sheep dung which is converted into methane gas through a digester process. Where for methane gas its potential will be analyzed to see how much power can be obtained from 5 Kg of goat or sheep dung.

## Methodology

The method used is based on field research and relies on the literature and references used to support research. Broadly speaking, there are several stages carried out that is

### Design of Biogas Production and Prototype of PLTB (Biogas)

The design for making biogas is simply made by collecting 5 Kg of goat manure mixed with 5 L of water, 300 mL of sugarcane juice, and 40 mL of EM4 then mixed until mixed and then put into a container and then compressed or vacuumed for 14-20 days until the methane gas is released. The methane gas produced is indicated by the expansion of the Gas Indicator Tube. Furthermore, the output of the gas is reprocessed into fuel for the PLTB Prototype (Biogas) as an indicator to see the potential of the biogas produced to generate electrical energy. For the design figure, it can be seen through the configuration figure as follows.

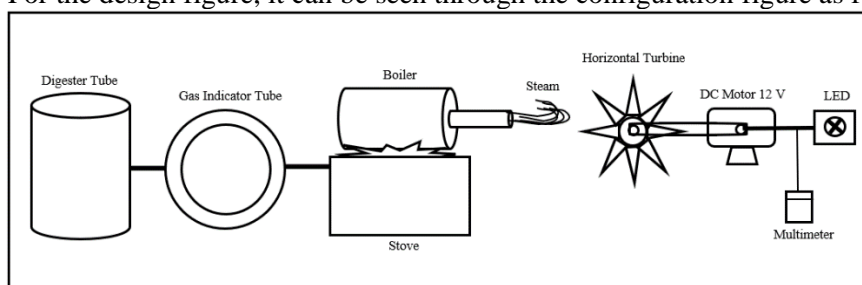

**Figure 1.** PLTB Prototype System Configuration (Biogas)

The PLTB (Biogas) prototype works on the principle of using steam pressure from the combustion of a boiler with biogas energy fuel, the steam pressure from the boiler will rotate the turbine, causing rotation on the turbine shaft which will make the generator rotate to produce electrical energy. The boiler tube used has a size of 700 mL with a horizontal turbine model with a diameter of 4 cm, and a 12V DC Motor as the generator. The measuring instrument used to see the value of the voltage and current generated by a DC motor is a Multimeter

### Collection of Tools and Materials

Tools and materials needed for the manufacture of biogas and PLTB Prototype (Biogas) can be described in Table 1 as follows

**Table 1** Tools and materials

Tools and materials (Biogas)		
No	Component	Specification
1.	Digester Tube	19 L
2.	Goat Dung	5 kg
3.	Water	5 L
4.	Small Hose	5 m
5.	Tap/ faucet	2 buah
6.	EM4	40 mL
7.	Sugarcane water	300 mL
Tools and materials (Prototype PLTB)		
No	Component	Specification
1.	Boiler	700 mL
2.	Stove	-
3.	Water	230 mL
4.	Dynamo (12 V)	12 V DC
5.	Wire	50 cm
6.	LED Lamp	0,036 Watt

#### Assembling of Biogas and PLTB Modeling (Biogas)

When the necessary tools and materials have been collected, all are then assembled according to the design figure that have been made. Biogas Production equipment and PLTB modeling are adjusted to the Design figure which, if actualized, is as shown in Figure 2 below



**Figure 2** PLTB Modeling Assembly (Biogas)

#### Observing and Analyzing the Results of Biogas Production

Observations were made to see whether the biogas produced had emitted methane gas and could be used for combustion or not. Analysis is also carried out to find out how much potential is produced by biogas for PLTB (Biogas) prototypes.



the 5<sup>th</sup> ICTROPS

International Conference  
for Tropical Studies and Its Applications

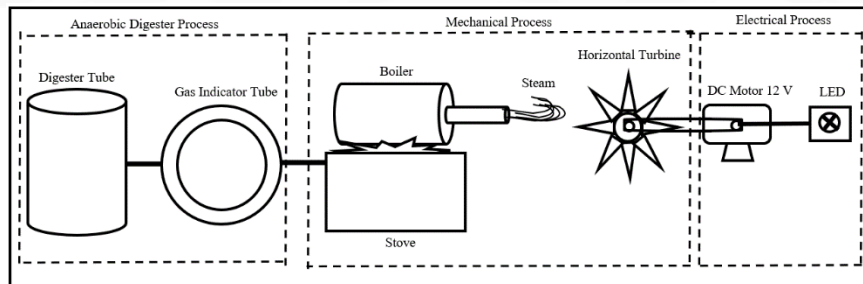

**Figure 3.** Configuration of PLTB Prototype System Testing (Biogas)

### Results and Discussion

In conducting the test of making biogas and the prototype of PLTB (Biogas), the first thing to analyze is the potential for methane gas that can be produced from 5 Kg of Goat Manure. From the Center for Agricultural Mechanization Development, Agency for Agricultural Research and Development, Ministry of Agriculture, source of BBKMP in 2008, it was found that 1.48 Kg of dry-based Goat Manure with a percentage of dry matter content of 26% resulted in a yield of 0.04 – 0.059 m<sup>3</sup>/Kg.BK (Kurniawan , 2019). The composition of biogas produced from goat manure is as follows:

**Table 2 Goat Manure Biogas Composition**

No	Element	Composition (%)
1	CH <sub>4</sub>	64,3
2	CO <sub>2</sub>	12,5
3	O <sub>2</sub>	6,2
4	BAL	17,0

For the calculation of the electrical power that can be produced 5 kg of goat dung

The dry matter content of goat manure with a percentage of 26%

$$BK = 5 \text{ Kg} \times 0,26 = 1,3 \text{ Kg} .BK$$

Potential Biogas that can be produced from 5 Kg of Goat Manure is

$$\text{Potential} = 1,3 \times 0,059 = 0,0767 \text{ m}^3$$

The potential for methane gas produced from goat manure is

$$CH_4 = 0,0767 \text{ m}^3 \times 64,3 \% = 0,0493181 \text{ m}^3$$

Conversion of 1 m<sup>3</sup> of biogas is equivalent to 0,62 L of kerosene, 0,48 Kg of LPG gas fuel, 5,5 Kg of Firewood and 1,64 Kg of charcoal (Kosman, 1997).

$$\text{Potensi LPG} = 0,0767 \text{ m}^3 \times 0,48 = 0,037 \text{ Kg LPG}$$

In the biogas production test, it was found that the biogas potential produced was 0,0767 m<sup>3</sup> with a methane gas content of 0,0493181 m<sup>3</sup> or equivalent to 0,037 Kg LPG. Based on observations of 0.22 Kg of LPG capable of burning for 110 minutes, for 0.037 Kg of Biogas it is able to produce combustion for approximately 18 minutes, so for this test we conducted a sample for 10 minutes.

Current and voltage are measured using a digital multimeter every 1 minute to calculate the power generated. The test was carried out for 10 minutes and the research results were obtained as shown in Table 3 below.

**Tabel 3 Potensi Daya listrik yang Dihasilkan**

Time	Rotating Turbine (Yes/No)	Current (A)	Voltage (Volt)	Power (Watt)	LED Light On (Yes/No)
1 Minute	No	0	0	0	No
2 Minute	No	0	0	0	No
3 Minute	Yes	0,0115	0,852	0,009798	No
4 Minute	Yes	0,0137	1,233	0,016892	No
5 Minute	Yes	0,0152	1,586	0,024107	No
6 Minute	Yes	0,0185	1,688	0,031228	No
7 Minute	Yes	0,0213	1,742	0,037104	No
8 Minute	Yes	0,0221	1,823	0,040288	No
9 Minute	Yes	0,0246	2.13	0,052398	Yes
10 Minute	Yes	0,0265	2.16	0,057240	Yes
Average		0,019175	1,65175	0,033631	

From Table 3 it can be seen that the power value from minutes 1 - 8 experienced an unstable turbine rotation due to the boiling of the boiler is still very small and has not reached its maximum boiling point so that the output issued is the LED light does not turn on as an indicator. At 9-10 minutes, the turbine rotation starts to stabilize so that the turbine rotation starts to increase in power which makes the maximum power generated which is indicated by the LED light as an indicator.

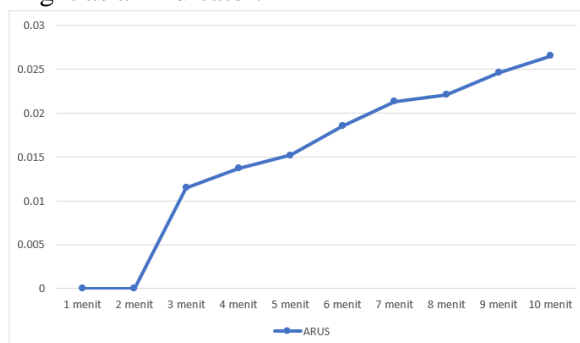

**Figure 4** Electric Current Graph



the 5<sup>th</sup> ICTROPS

International Conference  
for Tropical Studies and Its Applications

Islamic Development Bank 4in1 Project  
Project Implementation Unit  
University of Mulawarman



IsDB  
البنك الإسلامي للتنمية  
Islamic Development Bank

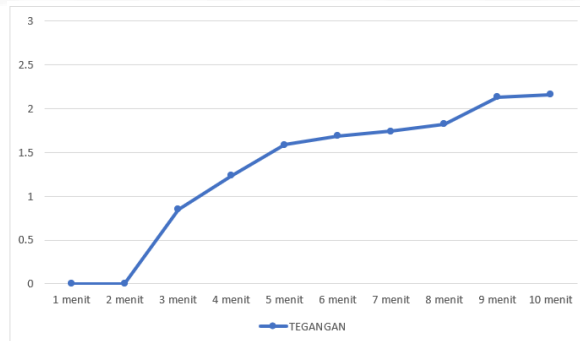

**Figure 5** Electric Voltage Graph

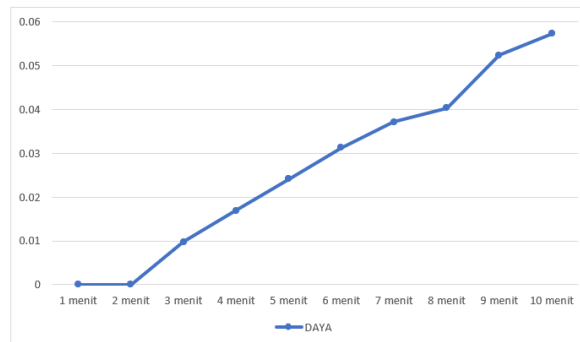

**Figure 6** Electric Power Graph

From graphs 3, 4 and 5 it can be said that the current, voltage and power values are directly proportional to the turbine operating time. This is because the longer the turbine is operated, the water temperature in the boiler will continue to increase until it reaches the maximum temperature which causes the volume of water in the boiler to decrease, resulting in a large steam pressure to drive the turbine. In addition, the current and voltage values that continue to increase are evidence that these values have reached a steady state or are already in a stable state if we look at the 9 and 10 minutes the resulting voltage value has a very small difference and increases. This proves that the Prototype of the Biogas Power Plant has begun to stabilize and can deliver power plants.

The influencing factor in making observations is the leaking of the digester tube which makes the research not maximal. In addition, external factors such as wind can cause the fire to not focus when burning or boiling the boiler

## Conclusions

The conclusions obtained from the testing and manufacture of biogas and the prototype of the PLTB (Biogas) generator are The test results of a simple power plant prototype with biogas energy converted from goat dung waste takes a minimum of 20 days. Biogas production is carried out for 20 days with activities to make tools for biogas production and biogas formation. From 5 kg of goat manure can



the 5<sup>th</sup> ICTROPS

International Conference  
for Tropical Studies and Its Applications

Islamic Development Bank 4in1 Project  
Project Implementation Unit  
University of Mulawarman



IsDB  
البنك الإسلامي للتنمية  
Islamic Development Bank



produce gas of 0,0767 m<sup>3</sup> or equivalent to 0,037 Kg of LPG Gas The methane gas produced is 0,493181 m<sup>3</sup> and is capable of burning for approximately 10 minutes. For the PLTB Prototype (Biogas) it produces no maximum power in 1-8 minutes with the output not turning on the LED lights and for maximum power generation in 9 and 10 minutes when the turbine has reached stability and can turn on the LED The average power generated is 0.033 Watt with an average voltage and current of 1.65 V and 0.033 A.

## REFERENCES

- Andik Yulianto. 2010. Study of Potential Utilization of Biogas as Electrical Energy Generator in East Kaliurang Hamlet, Hargobinangun Village, Pakem, Sleman, Yogyakarta. Yogyakarta. Indonesian Islamic University (Journal of environmental science and technology)
- Andik Yulianto. 2010. Studi Potensi Pemanfaatan Biogas Sebagai Pembangkit Energi Listrik di Dusun Kaliurang Timur, Kelurahan Hargobinangun, Pakem, Sleman, Yogyakarta. Yogyakarta. Universitas Islam Indonesia (Jurnal sains dan teknologi lingkungan)
- Kurniawan Puspito Aji. 2019. Converting Biogas Energy to Electrical Energy as a Renewable and Environmentally Friendly Energy Alternative in Langse Village, Margorejo District, Pati Regency. Poor. Tribhuwana Tungadewi University.
- Kurniawan Puspito Aji. 2019. Konversi Energi Biogas Menjadi Energi Listrik Sebagai Alternati Energi Terbarukan dan Ramah Lingkungan di Desa Langse, Kecamatan Margorejo Kabupaten Pati. Malang. Universitas Tribhuwana Tungadewi.
- Nahdia Puspawanti BR. 2018. Analysis of Biogas Power Plant Based on Green Technology Concept Case Study in Puter Kembangbahu Village. Lamongan. Lamongan Islamic University (JE-Unisla)
- Nahdia Puspawanti BR. 2018. Analisis Pembangkit Listrik Tenaga Biogas Berbasis Konsep Green Technology Studi Kasus di Desa Puter Kembangbahu. Lamongan. Universitas Islam Lamongan (JE-Unisla)
- Eswanto. 2018. ANALYSIS OF BIOGAS REACTOR MIXED GOAT dung WASTE WITH STRAW AND EM4 STANDARD SYSTEM. Medan. Medan Institute of Technology.
- Eswanto. 2018. ANALISA REAKTOR BIOGAS CAMPURAN LIMBAH KOTORAN KAMBING DENGAN JERAMI DAN EM4 SISTEM MENETAP. Medan. Institut Teknologi Medan.
- Latifah, S., et al. 2014. Conversion of Biogas Energy into Electrical Energy as an Alternative to Renewable and Environmentally Friendly Energy in Pangpajung Village, Madura. National LKTI. Gadjah Mada University. Yogyakarta.
- Latiefah, S., dkk. 2014. Konversi Energi Biogas Menjadi Energi Listrik Sebagai Alternatif Energi Terbarukan Dan Ramah Lingkungan Di Desa Pangpajung Madura. LKTI Nasional. Universitas Gadjah Mada. Yogyakarta.
- Wahyuni, A (2009). Operations Management Services First Edition. Yogyakarta: Graha Ilmu.
- Wahyuni, A (2009). Manajemen Operasi Jasa Edisi pertama. Yogyakarta : Graha Ilmu.
- Kosmann, W. 1997. Biogas Digest (Volume IV), Biogas-Country Report, ISAT & GTZ



[ictrops-idb.unmul.ac.id](http://ictrops-idb.unmul.ac.id)

Organized By :

Co-Organized By :

  **ISDB**  **Islamic Development Bank**  
البنك الإسلامي للتنمية  
Islamic Development Bank

**Islamic Development Bank 4in1 Project  
Project Implementation Unit  
Mulawarman University**