



2nd International Conference on Computer Science and Computational Intelligence 2017, ICCSCI
2017, 13-14 October 2017, Bali, Indonesia

User Satisfaction Model for e-Learning Using Smartphone

Ramadiani^{a*}, Azainil^b, Usfandi Haryaka^b, Fahrul Agus^a, Awang Harsa Kridalaksana^a

^a*Faculty of Computer Science and Information Technology, Mulawarman University, Indonesia*

^b*Faculty of Teacher Training and Education, Mulawarman University, Indonesia*

Abstract

Level of smartphone usage can be used as an indicator of technological progress of a region. This study aims to explore and make user satisfaction model for e-learning using smartphone applications in Mulawarman University. The purpose of the research is to make user satisfaction model for e-learning using smartphone, and to produce and to recommend e-learning content for research and e-learning. The components that would be evaluated in this research are focused on the following matters: User satisfaction for e-Learning using Smartphone; Service quality, Information quality, User participation, and Benefit. Where service quality consists of demeanor, responsiveness, competence and tangible. Information quality consist of completeness, relevancy, accuracy, and currency. User participation consist of training provider, user understanding and participation. Benefit consist of easier to the job and increase productivity. The research method used Path Diagram, Structural Equation Model, Lisrel and Manova Analysis. Total of respondent are 178 students which are consist of 83 females and 95 males. The statistical value in the model of e-learning user satisfaction has a highly significant correlation values and strong construction between variables, which is evidenced by the size of the construct reliability values above 0.70 and the value of its variance extracted 0.50 The model can be considered in developing an e-learning application in the future.

© 2017 The Authors. Published by Elsevier B.V.

Peer-review under responsibility of the scientific committee of the 2nd International Conference on Computer Science and Computational Intelligence 2017.

Keywords: e-Learning; User Satisfaction; SEM; Smartphone;

* Corresponding author.

Email addresses: ilkom.ramadiani@gmail.com

1. Introduction

E-Learning process on the internet can be done using a variety of platform or applications. It is expected to facilitate to transfer and to share the knowledge to the user. It does not mean to replace the existing class, it serves to enrich and be an alternative at the right time and needed¹. Many applications tools in educational content which the learner can access depending on its needs and learning style. A new learning style can reproduce the main role of the student to properly reform the traditional teaching and education, to train a large number of high-quality personnel¹.

But e-learning has limited in body language and social excuse also face to face learning session. We should be creative in multimedia learning. Planning and facilitating frequent and the relevant interaction is probably the single important that we can do to interactive virtual learning. We must be careful to designing e-learning interface interaction; it is not adding interaction in interactive activities seeks. This interaction must be had intends; engaged, paying attention, retaining the material that we are covering. It must be support leaning objectives and the same time supporting user attention.

2. Literature Review

2.1. E-Learning

People are involved in e-learning developers helping to make the course look good, make sure the student learn better and make the learning meaningful. However, we need to make sure that we were getting the performance of each individual who involved. We need to capture how the courses design, how the instructors have deliver the course to the learner, as we know many of e-learning courses design by someone else but taught by someone different, so comprehensive performance records of each individual should be noted. We can do comprehensive team evaluation how this course been taught, where is the students problems, if the problem is a content was miss represented, maybe we must to do updating. How to help learners feel engaged and encourage in active participation.

The interaction between user and system could be divided on several steps: the user should set a goal, determine what actions he should make to achieve this goal, make these actions, interpret a new system state and evaluate the result. It follows from this that duration of the user's work with system consists of the following components: duration of source information perception, duration of user's mental work, duration of user's physical work, during interaction with the computer the user enters data by means of different devices for information input and duration of system response. The criterion of user's mistakes such as mistakes caused insufficient data domain knowledge, these mistakes could be solved by user education. Misprints, it happens when the user for some reason does not attend to action that he makes in the present moment, paying no attention to system indication and motor mistakes².

The successful features of the program and its interface included; the interface actions supported the tasks the learner needed to perform, the screen layout drew the learner's eye to the right things, less-crucial actions were hidden rather than cluttering the screen, a tutoring component was always available to the learner, the entire program emphasized in-context, general information, the feedback and guidance were designed and written to aid generalization, the program design cut off learner paths so the learner stayed goal-focused; yet taught error recovery where it would be needed in real life and the learners did not need to click the mouse more than twice to complete an action³.

2.2. Smartphone for e-Learning

Smartphone is a communication tool whose ability is getting closer to the use of notebook. Although now the most popular activities performed on smartphones is accessing social media, but one day the smartphone can replace the function of the notebook in processing files and other important data. The most frequent activities of smartphone users are social media, group discussion, youtube, browsing, games, download, e-commerce, and entertainment news.

However, e-learning and other learning applications are the shortest activities of all activities, whether through smartphones or notebooks. Social learning concepts, micro-content, and informal learning are a result of the mobile learning surge. This research is the preliminary research of three stages of research. For the future research will be developed smartphone content that can be used for e-learning.

According to Pew Research Center ⁴ as many as 54 percent of adults in 21 developing countries are already using the internet. There are 21 percent of adults who use smartphones and will rise to 37 percent in 2014. In developed countries, 87 percent of adults are internet users and 68 percent already have smartphones. Smartphones are used for much more than calling, texting, or basic internet browsing. Users are turning to these mobile devices as they navigate a wide range of life events; 62% of smartphone owners have used their phone. Only 30% to take a class or get educational content and 18% to submit a job application.

The challenge facing educators today is how to utilize smartphone technology as a medium of education and knowledge sharing, whether formal or non-formal. The goal is to facilitate and expand the reach of education for those who cannot afford, not paying for professional teachers, unable to attend favorite places, disaster-stricken areas and remote provincial towns. As technology and applications continue to improve, more video content being utilized in eLearning environments ⁵. The use of mobile devices for learning will continue to rise as the number of people with mobile devices increases, along with the increased emphasis on optimizing websites and applications to accommodate mobile users.

2.3. User Acceptance and Satisfaction Model

Acceptance has been conceptualized as an outcome variable in a psychological process that users go through in making decisions about technology. Some researchers have been done to understand the human decision making in the context of accepting technology. According to the research, an individual's behavior is determined by one's intention to perform the behavior, and this intention is influenced jointly by the individual's attitude and subjective norm.

User acceptance is very important for all application developers to know their product which has been launched in public are accepted or rejected. Developer needs several evaluation models to investigate and to understand the factors affecting the acceptance of computer technology in organizations, as also designer and programmer. Besides following the application standard, the developers, programmer and application designer need knowledge to recognize their user and information seeking habitual. It is one of important reason to develop user acceptance model and evaluation standard. Among the models include Technology Acceptance Model (TAM), Theory of Reasoned Action (TRA) and Theory of Planned Behavior (TPB) ⁶.

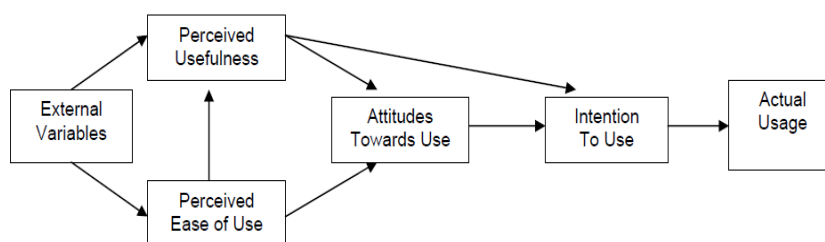

Fig 1. Technology Acceptance Model

The intention to accept or reject a particular technology is based on a series of tradeoffs between the perceived benefits of the system to the user and the complexity of learning or using the system. According to the TRA model, two major factors determine behavioral intentions namely: the person's attitude towards the behavior, and subjective norms. Attitude towards the behavior refers to the person's judgment that performing the behavior is good or bad. The TAM advances the TRA by postulating that perceived usefulness (PU) and perceived ease of use (PEU) are key determinants that predictably lead to the actual usage of a particular technology or system. The research found that there is a relationship between users' beliefs about a technology's usefulness and the attitude and the intention to use the technology ⁶.

The success of an information system according to this theory comes from the measurement of the quality of the system implemented by the information center in collecting and processing information, the measurement of the suitability between the quality of information content available to the needs of users, as well as measurement of the

quality of its services. The success of these three predecessor factors may affect the user to frequently or frequently use the facilities provided by the information services. Increased use of facilities provided by information services is an indicator for the satisfaction of information perceived by users. In the end, it all impacts on user behavior and also impact on the success of information systems. The point is that the service is useful for users in making decisions and facilitate users in carrying out their work and improve productivity and work efficiency ⁶⁻⁸.

The model developed by DeLone and McLean is one model of measuring the success of information systems seen from the point of non-economic output. This means that the success of the information system is measured by indirect measure or surrogate measure, in the form of user's perception, attitude and behavior. This is very appropriate with the way of measuring the success of information service systems in libraries that are not fully profit-oriented in the form of cost benefit analysis (Fig.2).

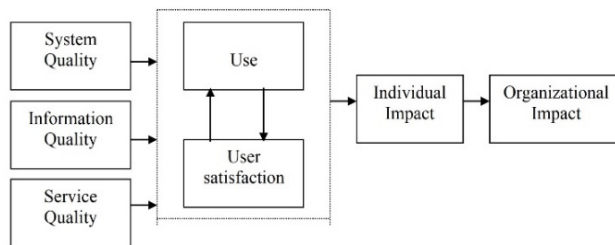

Fig. 2 Information System Success Model

Ozka proposed a conceptual e-learning assessment model, suggesting a multi-dimensional approach for LMS evaluation via six dimensions: (1) system quality, (2) service quality, (3) content quality, (4) learner perspective, (5) instructor attitudes, and (6) supportive issues. User satisfaction is a product of information satisfaction, system satisfaction and support satisfaction. Information satisfaction is affected by the quality of information which is attributed by availability, accuracy, timeliness, precision, reliability, currency, completeness. The user’s expectation on quality of information is demonstrated by his or her preferred information demand characteristic ⁹.

Table 1. User eLearning Satisfaction Model

Researchers	Observed Variables	Endogenous Variable
Parsazadeh <i>et al.</i> (2014),	6 variables + 4 variables	ease of access (EOA), interface design (ID), level of interaction (LOI), system quality (SQ), service quality (SEQ) and internet quality (IQ). User satisfaction, perceived usefulness (PU), technology acceptance model (TAM) and e-learning system.
Chien-Yun, Dai <i>et al.</i> (2011)	4 variables + 6 variables	perceived usefulness, perceived ease of use, behavioral intention to use and actual system use. Task definition, information seeking strategies, location and access, use of information, synthesis, and evaluation (Big Six)
Fanny Klett and Peter Pharow (2006)	7 variables	3 models; User interface design, Interactivity strategies, Easy of use (effectiveness, efficiency, satisfaction). Adaptivity and adaptability, interacting and performing, Learning in multiple acquisition mode, Active Learning Mode, Explorative Learning Mode, Support for Authoring Activities, Self-assessment
Dauw-Song Zhu <i>et al.</i> (2013)	9 variables	5 models; Theory of Reasoned Action (TRA) and Technology Acceptance Model (TAM), Informational System Success Model (D&M Model), User Satisfaction, Intention to Use.
This research (2017)	13 variables	4 models; Informational System Success Model (D&M Model), Service quality, User participation, and Benefit.

The components that would be evaluated in this research are focused on the following matters: User acceptance and satisfaction for e-Learning using Smartphone; Service quality, Information quality, User participation, and Benefit (Table 1). Where service quality consists of demeanor, responsiveness, competence and tangible. Information quality consist of completeness, relevancy, accuracy, and currency. User participation consist of training provider, user understanding and participation. Benefit consist of easier to the job and increase productivity ⁷⁻¹¹.

3. Research Method

3.1. Research Questions

User Information Satisfaction: Satisfaction is the summing up of a person's feelings or attitudes toward some of the circumstances affecting him while user satisfaction is a subjective judgment of the user against the information they find in comparison to the information they expect that exceeds their internal standard judgment¹¹. Internet users and smartphones worldwide are on the rise. The number of internet and smartphone users in developing countries close to 100 percent^{12,13}. Based on the background and focus of the research above, then the biggest challenge in this study is how to evaluate the smartphones usage among students in University. How to make user acceptance model and user satisfaction factors for e-learning using smartphone? and how to produce and to recommend e-learning content that suits the needs of students?

3.2. Structural Equation Model

Structural Equation Modeling (SEM) is a powerful collection of multivariate analysis techniques, which specifies the relationships between variables through the use of two main sets of equations: Measurement equations and structural equations. Measurement equations test the accuracy of proposed measurements by assessing relationships between latent variables and their respective indicators. The structural equations drive the assessment of the hypothesized relationships between the latent variables, which allow testing the statistical hypotheses for the study^{1,14}.

The general structural equation model can be expressed as follows: for example: $\eta = (\eta_1, \eta_2, \dots, \eta_m)$ and $\xi = (\xi_1, \xi_2, \dots, \xi_n)$ respectively are independent latent variable vectors and dependent latent variables. The structural linear relationship is as follows:

$$\eta = B\eta + \Gamma\xi + \zeta \quad (1)$$

Which B is a matrix of size $m \times m$ and Γ is a matrix of size $m \times n$, both of which are coefficient matrices. Whereas $\zeta = (\zeta_1, \zeta_2, \dots, \zeta_m)$ the random vector remains. Without prejudice to the general nature of the model, it can be assumed that $E(\eta) = E(\zeta) = 0$ and $E(\xi) = 0$. It is further assumed that ζ it is not correlated with ξ and $(I-B)$ is not singular. Vectors η and ξ cannot be directly observed, but instead are vectors $y = (y_1, y_2, \dots, y_p)$ and $x = (x_1, x_2, \dots, x_q)$ are directly observed, so that:

$$y = \Lambda_y \eta + \varepsilon \quad (2)$$

Where ε and δ is the measurement error vector for y and x . Taken y and x as corrected observation vectors against the mean. Matrices Λ_y of $p \times m$ and Λ_x sized $q \times n$ are, respectively, regression matrices y at η and x on ξ . This corresponds to y and x as the observed variable η and ξ as a latent variable. The measurement error vectors ε and δ are considered uncorrelated to each other, they are not correlated with the latent variables.

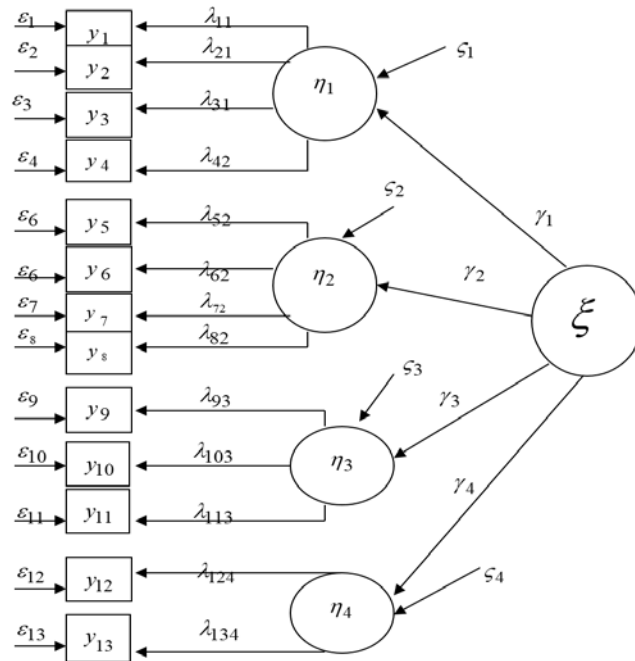

Fig. 3 User Satisfaction Model for e-Learning Using Smartphone

Where:

- ξ = User_Satisfaction
- η_1 = Sevqual
- η_2 = Infoqual
- η_3 = User
- η_4 = Benefit
- γ_1 = Demeanor
- γ_2 = Responsiveness
- γ_3 = Competence
- γ_4 = Tangible
- y_5 = Completeness
- y_6 = Relevancy
- y_7 = Accuracy
- y_8 = Currency
- y_9 = Training_Provider
- y_{10} = User_Understanding
- y_{11} = Participation
- y_{12} = Easier to the Job
- y_{13} = Increase_Productivity

4. Result and Discussion

The method used here is taking samples by spreading questionnaires to students of Mulawarman University. Produced sample data from 178 respondents with ages between 18 to 24 years whose average age range of 20 years. Fig. 3 we can see that still a few smartphone users access e-learning application. E-Learning applications used with smartphones are also limited compared to notebooks. Gnomia and Edmodo 34%, Group 7%, Moodle and journal 6%, Academia and article 5 %, Library 4%. Moodle is a well-known open-source Course Management System, with a large user community. The functionality is thus continuously being enhanced and the code is well maintained. Gnomio is a few moodle fans enjoying an unexpected success while offering free tools for the e-learning community. Edmodo takes learning beyond the classroom by providing a free, safe place for teachers and students to connect and collaborate, anytime, anywhere. Unlike an LMS, Edmodo lets us integrate and manage e-learning

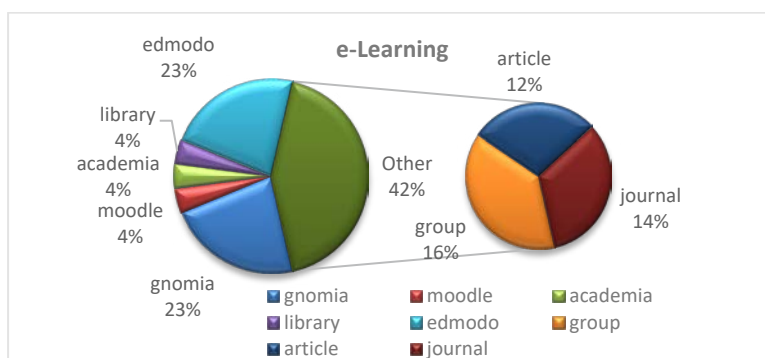

Fig 4. E-Learning Using Student Smartphone

This study has successfully developed an user acceptance model for e-Learning via smartphone, which is based on Sevqual, Infoqual, User participation and Benefit. Infoqual is consisted of four attributes; completeness, relevancy, accuracy, and currency. User participation consisted of three attributes; training provider, user understanding and participation. Benefit were consisted of easier to the job and increase productivity. The data collected is ordinal data and the estimation method used was the method of maximum likelihood. The data was processed by using Structural Equation Model (SEM) and Linear Structural Relation (LISREL) v8.80.

Table 2. Parameter and Variant Estimates user satisfaction model

	Satisfaction (Estimasi) (γ)	Err-Var (ζ)	Satisfaction (standar solution) (γ)	Err-Var (ζ)	R^2
Serqual	1.00	0.01	0.99	0.01	0.99
Infoqual	0.86 (0.036)	0.15 (0.028)	0.90	0.19	0.81
	23.70	5.50			
User	0.89 (0.031)	0.24 (0.026)	0.86	0.27	0.73
	28.58	9.34			
Benefit	1.05 (0.028)	0.01	0.99	0.01	0.99
	37.12				

The research statistics used Structural Equation Model using LISREL v8.80 and MANOVA while analysis of the data was performed using SPSS v21. SEM determines the suitability of model. Meanwhile, its validity and reliability was measured by composite construct reliability and variance extracted measure. MANOVA analysis was used to compare the difference level of user acceptance.

Based on the statistical value in the model of e-learning user satisfaction has a highly significant correlation values and strong construction between variables, which is evidenced by the size of the construct reliability values above 0.70 and the value of its variance extracted 0.50 (Table 3). According to the research questioner analysis and Goodness of Fit measurement, it is shown that the high reliability in this study indicates that an indicator variable is consistently high in measuring latent constructs. Test reliability used two types of measurements composite construct reliability and variance extracted measure.

Table 3. Calculation of Variance Extracted and Construct Reliability of user satisfaction Model

	Construct Reliability	Variance Extracted
Service quality	0.95	0.87
Information quality	0.95	0.83
User Participation	0.98	0.93
Benefit	0.99	0.98
User Satisfaction	0.97	0.89

Calculation of Variance Extracted and Construct Reliability in user satisfaction model is done by using the formula and data contained in the research as an example:

- Construct Reliability Service quality

$$(\sum \text{Standardized Loading})^2 = (0.94 + 0.99 + 0.86)^2 = 2.79^2 = 7.78$$

$$\sum \varepsilon_j = 0.13 + 0.01 + 0.26 = 0.4$$

$$\text{Construct Reliability Service quality} = \frac{7.78}{7.78 + 0.4} = 0.95$$

- Variance Extracted Service quality

$$\sum \text{Standardized Loading}^2 = 0.94^2 + 0.99^2 + 0.86^2 = 2.6$$

$$\sum \varepsilon_j = 0.13 + 0.01 + 0.26 = 0.4$$

$$\text{Variance Extracted Service quality} = \frac{2.6}{2.6 + 0.4} = 0.87$$

According to the t-value, loading factors, and the relative suitability value of each Structural Equation Model, we can conclude that the user satisfaction model for E-learning using smartphone in this study can be accepted. The measurement modal and structural model has very significant correlation between variables. This study has become one alternative model to predict the user satisfaction model for E-learning using smartphone.

References

1. Ramadiani et al. Integrated Acceptance Model for E-Learning. International Conference on Engineering and Technology for Sustainable Development (ICET4SD) 2015, 11–12 Nov, Yogyakarta, Indonesia. IOP Conf. Series: Materials Sci. and Engineering, Vol.105, No.1 2016
2. Aaron Smith. U.S. Smartphone Use in. Pew Research Center, 2015.
3. Lee, Mathew K.O. dan Pow, Jacky. Information Accessing Behavior and Expectation of Quality: Two Factor Affecting the Satisfaction of Users of Clinical Hospital Information Systems. Journal of Information Science 1996, 22(3): 171-179.
4. Ghazal Bargshady et al. The Effective Factors on User Acceptance in Mobile Business Intelligence. Jurnal Teknologi (Sciences & Engineering) 2015, 72 (4): 49–54.
5. Belaya Ozka. A. The metrics for quantitative evaluation of user interface usability construction methodology. SPECOM: 9th Conference Speech and Computer St. Petersburg, Russia, 2004 Sept 20-22.
6. Gelderman, Marteen. The Relationship Between User Satisfaction, Usage of Information Systems and Performance. Information and Management, 1998, 34:11-18.
7. Nadia Parsazadeh, et.al. Technological Aspects of E-learning System in Malaysian Context, International Conference on Teaching and Learning in Computing and Engineering, IEEE; 70-73, 2014.
8. Chien-Yun, Dai at all. The Study on Exploring the User Satisfaction of Easy Teaching Web of Taipei by Information-Seeking and Technology Acceptance Model, IEEE; 7007-7011, 2011.
9. Fanny Klett and Peter Pharow. How to Achieve User Satisfaction in Complex E-Learning Environments. Special Session Future Technologies. IEEE, 2006.
10. Dauw-Song Zhu, Wei-Te Lee, Yi-Kang Chen. A Study on the Customer Satisfaction and Using Intention of E-learning, IEEE; 251-254, 2013
11. Iivari J., Ervasti, I. User Information Satisfaction: IS Implement, ability and Effectiveness. Information and Management, 27: 205-220, 1994.
12. Bruce, Harry. User Satisfaction with Information Seeking on the Internet. Journal of American Society for Information Science, 49(6): 541-556, 1997.
13. Lina Wu, Mincheol Kang and Sung-Byung Yang. What Makes Users Buy Paid Smartphone Applications? Examining App, Personal, and Social Influences. Journal Internet and Banking (JIBC), August, Vol. 20, 1, 2015.
14. Ramadiani, et.al. E-Learning User Acceptance based on Analysis of User's Style, Usability, and User Benefits, JSI, Vol 9, 1: page 6-12. 2013.